

1996 Jeep Cherokee

O w n e r ' s M a n u a l

VEHICLES SOLD IN CANADA

With respect to any vehicles sold in Canada, the name Chrysler Corporation shall be deemed to be deleted and the name Chrysler Canada Ltd. used in substitution therefor.

DRIVING AND ALCOHOL

Driving after drinking is one of the most frequent causes of accidents.

Your driving ability can be seriously impaired with blood alcohol levels far below the legal minimum. If you are drinking, don't drive. Ride with a designated nondrinking driver, call a cab, a friend, or use public transportation.

WARNING!

Driving after drinking can lead to an accident. Your perceptions are less sharp, your reflexes are slower, and your judgment is impaired when you have been drinking. Never drink and then drive.

PROTECT OUR ENVIRONMENT

Jeep is a founding member of Tread Lightly, Inc., a non-profit educational corporation dedicated to promoting increased public awareness of land-use regulations and responsible use of our nation's wild lands.

For more information, call 1-800-966-9900 or write to
Tread Lightly!
P.O. Box 149
Ogden, Utah 84402-0149

Copyright © 1995 Chrysler Corporation



CONTENTS

- An Important Message Corporation.
- Introduction
- How To Use This Man

INTRODUCTION

1

CONTENTS

- | | | | |
|---|---|---|---|
| ■ An Important Message To You From Chrysler Corporation | 4 | ■ Warnings And Cautions | 6 |
| ■ Introduction | 5 | ■ Vehicle Identification Number | 6 |
| ■ How To Use This Manual | 5 | | |

AN IMPORTANT MESSAGE TO YOU FROM CHRYSLER CORPORATION

Thank you for selecting a Jeep Cherokee and welcome to our worldwide family.

A 4-wheel drive Jeep is a specialized utility vehicle designed for both on-road and off-road use. It can go places and perform tasks for which conventional 2-wheel drive vehicles were not intended. However, on-pavement ride and handling will have a different feel from what drivers experience with other vehicles, so take time to become familiar with your vehicle.

The 2-wheel drive utility vehicle was designed for on-road use only. It is not intended for off-road driving or use in other severe conditions suited to a 4-wheel drive vehicle.

This vehicle has a higher ground clearance, higher center of gravity and narrower track than many passenger cars. It is capable of performing better in a wide variety of

off-road applications. Driven in an unsafe manner, all vehicles can be caused to go out of control. Because of the higher center of gravity and the narrower track, if this vehicle is out of control it may roll over when some other vehicles may not. Do not attempt sharp turns or abrupt maneuvers or other unsafe driving actions that can cause loss of vehicle control. Failure to operate this vehicle safely may result in an accident, rollover of the vehicle and severe or fatal injury. Drive carefully.

Failure to use driver and passenger seat belts provided as standard equipment on nearly all vehicles is a major cause of severe or fatal injury. In fact, the U.S. government notes that the universal use of existing seat belts could cut the highway death toll by 10,000 or more each year, and could reduce disabling injuries by 2 million annually. Always buckle up.

Before you start to drive this vehicle, read this manual. Be sure you are familiar with all vehicle controls, particu-

larly those used for braking, shifting. Learn how to drive on road surfaces. Your driving experience. When driving this vehicle, don't overload it. Observe local laws wherever you

As with other vehicles, driving a vehicle correctly may prevent an accident. Be sure to read the driving guidelines in the

INTRODUCTION

This manual has been prepared by service and engineering personnel for the operation and maintenance. It is supplemented by a variety of various customer oriented

Early those used for braking, steering and transmission shifting. Learn how your vehicle handles on different road surfaces. Your driving skills will improve with experience. When driving off-road or working the vehicle, don't overload it or expect it to overcome the laws of nature. Always observe federal, state, provincial and local laws wherever you drive.

As with other vehicles of this type, failure to operate this vehicle correctly may result in loss of control or an accident. Be sure to read On-Pavement and Off-Road driving guidelines in this manual.

INTRODUCTION

This manual has been prepared with the assistance of service and engineering specialists to acquaint you with the operation and maintenance of your new vehicle. It is supplemented by a Warranty Information Booklet and various customer oriented documents. You are urged to

read these publications carefully. Following the instructions and recommendations in this manual will help assure safe and enjoyable operation of your vehicle.

NOTE: After you read the manual, it should be stored in the vehicle for convenient reference and remain with the vehicle when sold.

When it comes to service, remember that your Chrysler Corporation dealer knows your vehicle best, has the factory-trained technicians and genuine Mopar® parts and is interested in your satisfaction.

HOW TO USE THIS MANUAL

Consult the table of contents to determine which section contains the information you desire.

The detailed index, at the rear of this manual, contains a complete listing of all subjects.

WARNINGS AND CAUTIONS

This manual contains **WARNINGS** against operating procedures which could result in an accident or bodily injury. It also contains **CAUTIONS** against procedures which could result in damage to your vehicle. If you do not read this entire manual you may miss important information. Observe all Warnings and Cautions.

VEHICLE IDENTIFICATION NUMBER

The vehicle identification number (VIN) is found on a stamped plate located on the left front corner of the instrument panel pad, visible from outside of the vehicle through the windshield. This number also appears on the Automobile Information Disclosure Label affixed to a window on your vehicle. Save this label for a convenient record of your vehicle identification number and optional equipment.

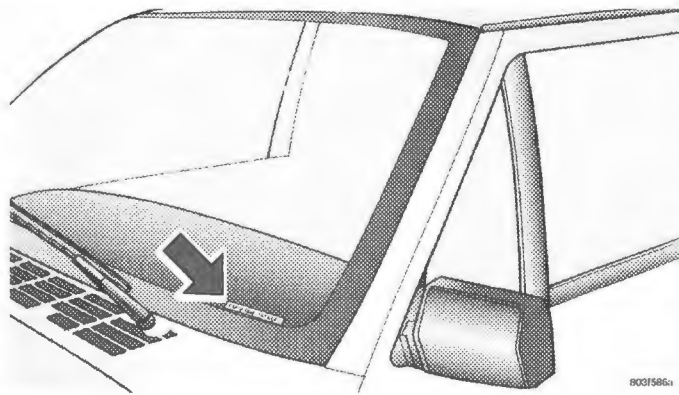

NOTE: It is illegal to remove the VIN plate.

THINGS TO

CONTENTS

- A Word About Your
- Ignition And Steering
 - Key-In-Ignition Re
- Door, Liftgate And G
- Door Locks
 - Child Protection L
 - Power Door Locks
- Occupant Restraints.
 - Seat Belt Warning L

THINGS TO KNOW BEFORE STARTING YOUR VEHICLE

2

CONTENTS

- A Word About Your Keys 9
- Ignition And Steering Lock 9
 - Key-In-Ignition Reminder 10
- Door, Liftgate And Glove Box Key 10
- Door Locks 11
 - Child Protection Locks 12
 - Power Door Locks 13
- Occupant Restraints 13
 - Seat Belt Warning Light 14
 - Unibelts 14
 - Rear Center Lap Belt 18
 - Seat Belts And Pregnant Women 19
 - Seat Belt Extender 19
 - Child Restraint 20
 - Driver Supplemental Restraint System — Airbag 23
- Engine Break-In Recommendations 28
- Checking Your Vehicle For Safety 29
 - Exhaust Gas 29

8 THINGS TO KNOW BEFORE STARTING YOUR VEHICLE

Safety Checks You Should Make Inside The Vehicle 30

Safety Checks You Should Make Outside The Vehicle 30

A WORD ABOUT Y

The double sided k
with either side up.
enclosed in a plastic
the front. The bar c
keys from your dea
your keys without t
the number. One ke
ignition, door and g

IGNITION AND STE

In the LOCK positio
are locked to prov
vehicle. It may be dif
position when starti
wheel left and right
easily. The key can b
LOCK position. Pus
ylinder to rotate to

A WORD ABOUT YOUR KEYS

The double sided keys may be inserted into the locks with either side up. The keys for your new vehicle are enclosed in a plastic bag with a bar code label affixed to the front. The bar code can be used to order duplicate keys from your dealer or a locksmith. If you received your keys without the bag, ask your dealer to give you the number. One key is common to all vehicle locks; ignition, door and glove box.

IGNITION AND STEERING LOCK

In the LOCK position, the steering and ignition systems are locked to provide anti-theft protection for your vehicle. It may be difficult to turn the key from the LOCK position when starting your vehicle. Move the steering wheel left and right while turning the key until it turns easily. The key can be inserted or withdrawn only in the LOCK position. Push in on the key in the ignition lock cylinder to rotate to the LOCK position.

NOTE: On vehicles equipped with an automatic transmission, the key cannot be turned to LOCK until the selector is in the PARK position. Do not attempt to pull the shift lever out of PARK after the key is in the LOCK position.

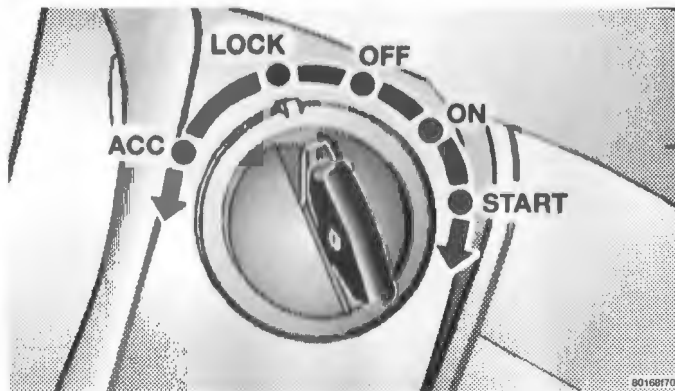

CAUTION!

Always remove the key from the ignition and lock all doors when leaving the vehicle unattended.

Key-In-Ignition Reminder

If the driver's door is opened when the key is in the ignition, a signal will sound to remind you to remove the key.

DOOR, LIFTGATE AND GLOVE BOX KEY

The same key used to start the vehicle is also used to unlock the doors, liftgate and glove box. To unlock vehicle doors, liftgate or glove box, insert the key into the lock and turn.

To lock doors or liftgate, insert the key and turn. Once unlocked, the liftgate can be opened or closed without using the key. To open the liftgate, press in the lock button to release the latch.

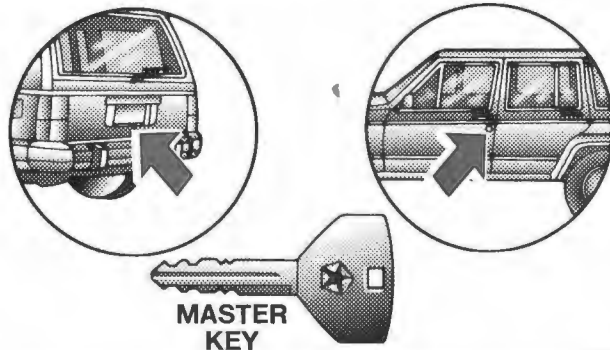

8046036

WARNING!

Driving with the liftgate open can allow poisonous exhaust gases into your vehicle. You and your passengers could be injured by these fumes. Keep the liftgate closed when you are operating the vehicle.

To unlock glove box, insert the key into the latch buttons on the glove box.

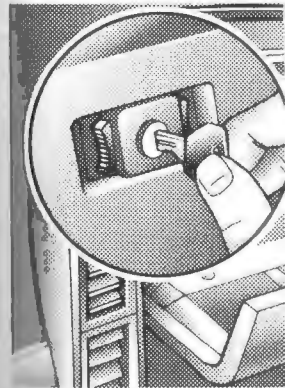

DOOR LOCKS

All doors are equipped with a lock. To lock a door, insert the key into the LOCK position and turn.

To unlock glove box, insert key and turn. To open, press the latch buttons on both sides of the lock.

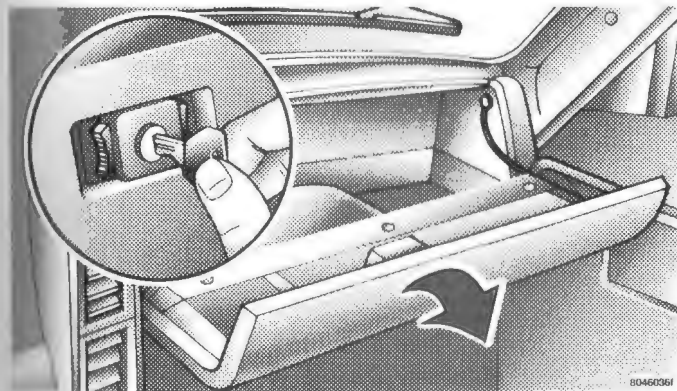

DOOR LOCKS

All doors are equipped with a rocker-type interior door lock. To lock a door when leaving your vehicle, press to the LOCK position and close door.

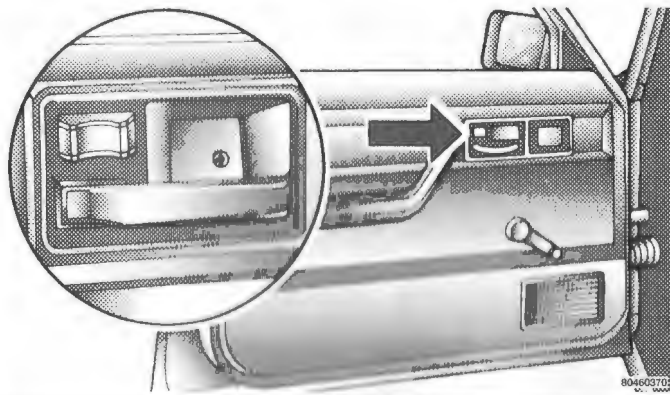

2

WARNING!

For personal security reasons and safety in a collision, lock the vehicle doors when you drive as well as when you park and leave the vehicle.

Child Protection Locks

The rear doors of your vehicle are equipped with child protection locks. With the lever on the open edge of the door positioned toward the outside of the vehicle, the doors cannot be opened from the inside.

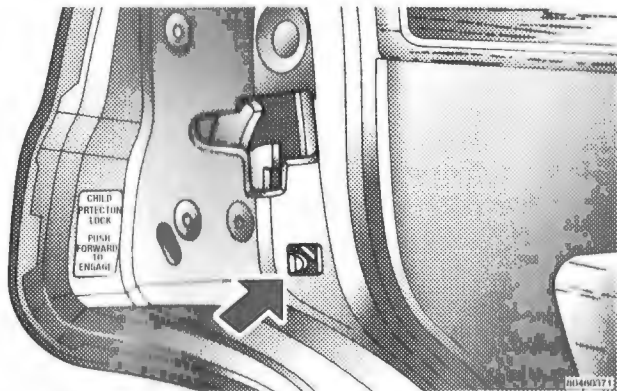

WARNING!

Avoid trapping anyone in the vehicle in a collision. Remember that the rear doors can only be opened from the outside when the child protection locks are engaged.

Power Door Locks

Push down to lock, up to unlock. Operates all doors, including the trunk.

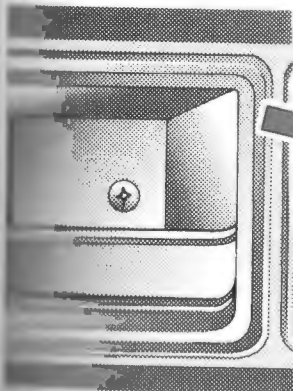

OCCUPANT RESTRAINT

One of the most important parts of the restraint system. The

Power Door Locks

Push down to lock, up to unlock. The driver's panel operates all doors, including the liftgate.

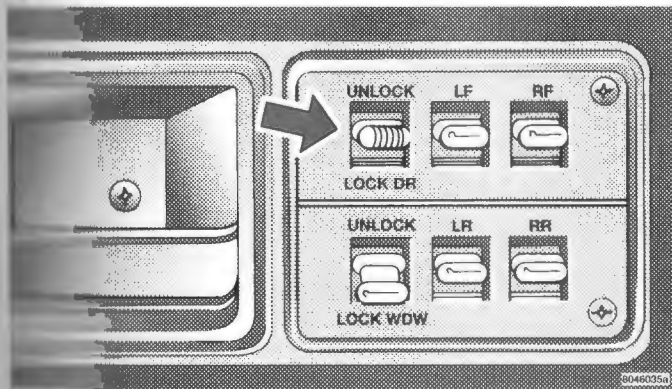

OCCUPANT RESTRAINTS

One of the most important safety features in your vehicle is the restraint system. This system includes the front and

rear seat belts. Your seat belts can also be used to hold infant and child restraint systems if you will be carrying children too small for adult-size belts.

Please pay careful attention to the information in this section. It tells you how to use your restraint system properly to keep you and your passengers as safe as possible.

2

WARNING!

In a collision you and your passengers can suffer much greater injuries if you are not properly buckled up. You can strike parts of the inside of the vehicle or other passengers, or you can be thrown out of the vehicle. Always be sure you and others in your vehicle are buckled up properly.

WARNING!

It is extremely dangerous to ride in a cargo area, inside or outside of a vehicle. In a collision, people riding in these areas are likely to be seriously injured or killed.

Do not allow people to ride in any area of your vehicle that is not equipped with seats and seat belts.

Be sure everyone in your vehicle is in a seat using a seat belt properly.

Buckle up even though you are an excellent driver. Even on short trips. Someone else on the road may be a poor driver and cause a collision which involves you. And this can happen far from home or on your own street.

Research has shown that seat belts save lives. And they can reduce the seriousness of injuries in a collision. Some of the worst injuries happen when people are thrown

from the vehicle. Seat belts provide protection against that, and they reduce the risk of injury caused by striking the inside of the vehicle. Everyone in a motor vehicle needs to be buckled up all the time.

Seat Belt Warning Light

A warning chime or buzzer and an indicator light will alert you to buckle the seat belts.

Unibelts

The outboard front and rear seats of your vehicle have combination lap/shoulder belts, or unibelts. The retractor is designed to lock during very sudden stops or impacts. This feature allows the shoulder part of the belt to move freely with you under normal conditions. But in a collision, the belt will lock and reduce the risk of your striking the inside of the vehicle or being thrown out.

Unibelt Operating Instructions

1. Enter the vehicle and close the door. Sit back and adjust the seat.

2. The latch plate of the seat. Grasp the latch plate latch plate up the webbing the belt go around your



2 The latch plate of the belt is above the back of your seat. Grasp the latch plate and pull out the belt. Slide the latch plate up the webbing as far as necessary to make the belt go around your lap.

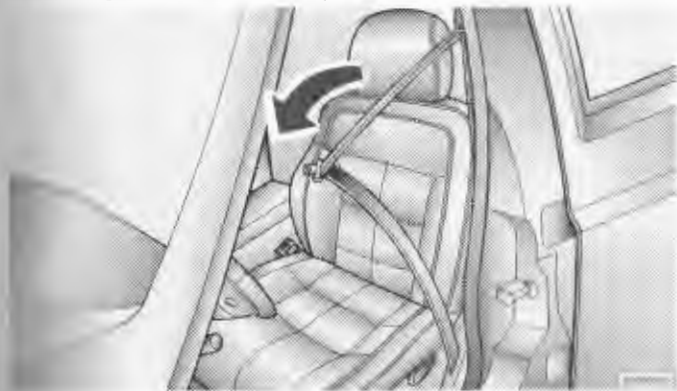

3. When the belt is long enough to fit, insert the latch plate into the buckle until you hear a "click".

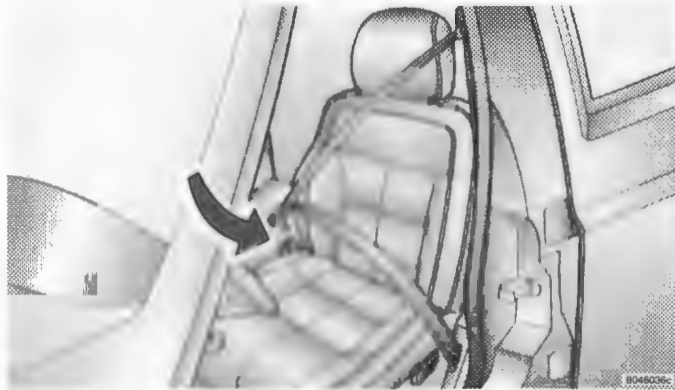

WARNING!

A belt buckled into the wrong buckle will not protect you properly. The lap portion could ride too high on your body, possibly causing internal injuries. Always buckle your belt into the buckle nearest you.

WARNING!

- A belt that is too loose will not protect you as well. In a sudden stop you could move too far forward, increasing the possibility of injury. Wear your seat belt snugly.
- A shoulder belt worn under your arm is very dangerous. Your body could fall into the inside surfaces of the vehicle in a crash, increasing head and neck injury. And a belt worn under the arm can cause internal injuries. Ribs aren't as strong as shoulder bones. Wear the belt over your shoulder so that your strongest bones will take the force in a collision.

4. Position the lap belt
abdomen. If you need th
on the shoulder part.
sliding under the belt i

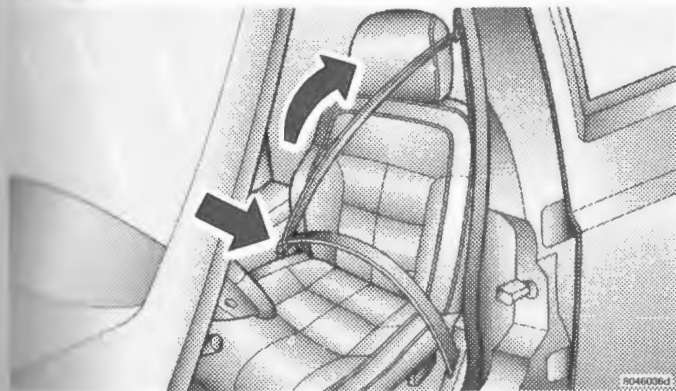

4. Position the lap belt across your thighs, below your abdomen. If you need the lap portion tighter, pull up a bit on the shoulder part. A snug belt reduces the risk of sliding under the belt in a collision.

**WARNING!**

A lap belt worn too high can increase the risk of internal injury in a collision. The belt forces won't be at the strong hip and pelvic bones, but across your abdomen. Always wear the lap part of your seat belt as low as possible, and keep it snug.

2

5. Position the shoulder belt on your chest so that it is comfortable and not resting on your neck. The retractor will withdraw any slack in the belt.

WARNING!

A twisted belt can't do its job as well. In a collision it could even cut into you. Be sure your belt is straight. If you can't straighten a belt in your vehicle, take it to your dealer and have it fixed.

6. To release the belt, push the button on the buckle. The belt will automatically retract to its stowed position.

If necessary, slide the latch plate down the webbing to allow the belt to retract fully.

WARNING!

A frayed or torn belt could rip apart in a collision and leave you with no protection. Inspect your belts periodically, checking for cuts, frays, and loose parts. Damaged parts must be replaced immediately. Do not disassemble or modify the system. Seat belt assemblies must be replaced immediately after an accident if they have been damaged (bent retractor, torn webbing, etc.).

Rear Center Lap Belt

The rear center seating position has a lap belt only.

To fasten a lap belt, slip the latch plate into the buckle.

To lengthen the lap belt, tilt the latch plate and pull. To shorten the belt, pull the loose end of the webbing.

Wear the lap belt snug against the hips. Sit back and erect in the seat, then adjust the belt as tightly as is comfortable.

- Wa
- A lap belt worn too loose and under the belt in the high will apply crash force to the stronger hip bones. Internal injuries is greater.
 - Belting two people together will result in greater injury. People will be thrown into one another in a crash. Never use a seat belt for more than one person, no matter what.

WARNING!

- **A lap belt worn too loose or too high is dangerous. A belt worn too loose can allow you to slip down and under the belt in a collision. A belt that is too high will apply crash forces to the abdomen, not to the stronger hip bones. In either case, the risk of internal injuries is greater. Wear a lap belt low and snug.**
- **Belting two people into one seat belt can lead to greater injury. People belted together can crash into one another in an accident, hurting one another badly. Never use a belt for more than one person, no matter what their size.**

Seat Belts And Pregnant Women

We recommend that pregnant women use seat belts throughout their pregnancies. Keeping the mother safe is the best way to keep the baby safe.

Pregnant women should wear the lap part of the belt across the thighs and as snug against the hips as possible. Keep the belt low so that it does not come across the abdomen. That way the strong bones of the hips will take the force if there is a collision.

Seat Belt Extender

If a seat belt is too short, even when fully extended, your dealer can provide you with a seat belt extender. This extender should be used only if the existing belt is not long enough. When it is not required, remove the extender and stow it.

WARNING!

Using a seat belt extender when not needed can increase the risk of injury in a collision. Only use when the lap belt is not long enough when it is worn low and snug, and in the recommended seating positions. Remove and stow when not needed.

Child Restraint

When we say that everyone in your vehicle needs to be buckled up all the time, we mean babies and children, too.

Every state in the United States and all Canadian provinces require small children to ride in proper restraint systems. This is the law, and you can be prosecuted for ignoring it.

WARNING!

In a collision, an unrestrained child, even a tiny baby, can become a missile inside the vehicle. The force required to hold even an infant on your lap could become so great that you could not hold the child, no matter how strong you are. The child and others could be badly injured. Any child riding in your vehicle should be in a proper restraint for the child's size.

Infants And Small Children

There are different sizes and types of restraints for children from newborn size to the bigger child almost large enough for an adult safety belt. Use the restraint that is correct for your child.

Two different child restraint systems are generally available.

- The infant carrier for b (kg.)
 - The child seat for small
- In addition, some manufa
be used first as an infant d
child seat as the child gro
- Here are some tips on gett
restraint:
- Before buying any restr
has a label certifying tha
standard 213. We also r
a child restraint, you tr
where you will use it.
 - The restraint must be
weight and height. Che
this, too.

- The infant carrier for babies weighing up to 20 lbs. (9 kg.)
- The child seat for small children over 20 lbs.

In addition, some manufacturers make systems that can be used first as an infant carrier, and then converted to a child seat as the child grows.

Here are some tips on getting the most out of your child restraint:

- Before buying any restraint system, make sure that it has a label certifying that it meets Motor Vehicle Safety Standard 213. We also recommend that before you buy a child restraint, you try it in the vehicle in the seats where you will use it.
- The restraint must be appropriate for your child's weight and height. Check the label on the restraint for this, too.

- If possible, install the restraint in the rear seat. According to accident statistics, children are safer when properly restrained in the rear seats rather than in the front.
- Carefully follow the instructions that come with the restraint. If you install the restraint improperly, it may not work when you need it.

2

WARNING!

Improper installation can lead to failure of an infant or child restraint. It could come loose in a collision. The child could be badly injured or killed. Follow the manufacturer's directions exactly when installing an infant or child restraint.

- Infant and child restraints are secured in vehicle seats by the lap belt or the lap part of the lap/shoulder belt.

22 THINGS TO KNOW BEFORE STARTING YOUR VEHICLE

In the rear seat, you may have trouble tightening the belt on the child restraint because the buckle or latch plate interferes with the belt path opening on the restraint. Disconnect the latch plate from the buckle and twist the short buckle-end belt several turns to shorten it. Reassemble the latch plate to the buckle with the release button facing out.

In the front seat, move the seat forward to reposition the buckle against the side of the child restraint.

In the center rear seat, if the belt still can't be tightened or if pulling and pushing on the restraint loosens the belt, you may need to do something more. Disconnect the latch plate from the buckle, turn it over, and reconnect it to the buckle. If you still can't make the child restraint secure, try a different seating position.

- Buckle the child into the restraint exactly as the seat manufacturer's directions tell you. The cinching latch plate will keep the belt tight.
- When your infant carrier or child restraint is not in use, secure it with the seat belt or remove it from the vehicle. Don't leave it loose in the vehicle. In a sudden stop or collision it could strike occupants and injure them.
- Some child seat manufacturers recommend the use of a top anchorage (tether) strap in addition to the lap belt. Your vehicle has tether strap anchorages behind the rear seating positions for use with these child seats.

WA

An incorrectly anchored seat failure and injury to the seat could come loose and into the inside of the vehicle even be thrown from the specified anchor position requiring top tether strap below. See your dealer

Children Too Large For C

Children who are too large to sit upright by themselves should use shoulder belts for best protection.

- Make sure that the child is seated upright.
- The lap belt should be fastened snug as possible.

WARNING!

An incorrectly anchored tether strap could lead to seat failure and injury to the child. In a collision, the seat could come loose and allow the child to crash into the inside of the vehicle or other passengers, or even be thrown from the vehicle. Use only the specified anchor positions to secure a child restraint requiring top tether strap(s). Follow the instructions below. See your dealer for help if necessary.

Children Too Large For Child Seats

Children who are too large for child seats and who can sit upright by themselves should use the available lap/shoulder belts for best protection.

- Make sure that the child is seated upright in the seat.
- The lap belt should be fastened low on the hips and as snug as possible.

- Check belt fit periodically. A child's squirming or slouching can move the belt out of position.

If the shoulder belt contacts the face or neck, move the child closer to the middle of the vehicle. If this doesn't solve the problem, move the child to a rear seat lap belt.

Booster seats that may help overcome this problem are also available for use with lap/shoulder belts. Before buying a booster seat, make sure it has a label certifying that it meets applicable Motor Vehicle Safety Standards. Make sure it is satisfactory for use in this vehicle.

Driver Supplemental Restraint System — Airbag

The vehicle has an airbag for the driver as a supplement to the seat belt restraint system. The airbag is mounted in the steering wheel. Its job is to inflate in higher speed frontal impacts. It works with the instrument panel knee bolster and the seat belt to provide improved protection for the driver.

WARNING!

Relying on the airbag alone could lead to more severe injuries in a collision. The airbag works with your seat belt to restrain you properly. In some collisions the airbag won't deploy at all. Wear your seat belt even though you have an airbag.

The seat belt is designed to protect you in many types of collisions. The airbag deploys only on frontal collisions. It will not deploy in collisions at slow speeds. Even in collisions where the airbag does work, you need the seat belt to keep you in the right position for the airbag to protect you properly.

The airbag system consists of the following:

- Airbag Module
 - Crash Sensor
 - Inflator Assembly
 - Airbag Cushions
 - Trim Cover
- Unique Steering Wheel and Column
- Knee Impact Bolster

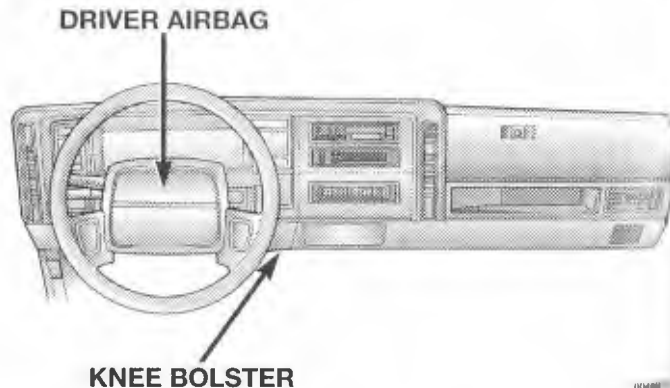

How The Airbag System
 The Crash Sensor/Inflator
 steering wheel at the back
 crash sensor provides ve
 severity of the impact. WH
 impact requiring the airb
 large quantity of non-toxi
 inflate the airbag. The st
 separates and folds out of
 full size. The bag fully infl
 This is about half of the ti
 It then quickly deflates
 through the back panel of
 ment panel. In this way th
 your control of the vehicle

How The Airbag System Works

The Crash Sensor/Inflator assembly is located in the steering wheel at the back of the airbag module. The crash sensor provides verification of the direction and severity of the impact. When the crash sensor detects an impact requiring the airbag, it activates the inflator. A large quantity of non-toxic nitrogen gas is generated to inflate the airbag. The steering wheel hub trim cover separates and folds out of the way as the bag inflates to full size. The bag fully inflates in about 50 milliseconds. This is about half of the time it takes to blink your eyes. It then quickly deflates by venting the nitrogen gas through the back panel of the airbag towards the instrument panel. In this way the bag does not interfere with your control of the vehicle.

If A Deployment Occurs

The airbag system is designed to deploy at a precisely calibrated vehicle deceleration force and is not linked to vehicle road speed. The ignition does not have to be on for the airbag to deploy.

NOTE: A frontal collision that is not severe enough to need airbag protection will not activate the system. This does not mean something is wrong with the airbag system.

If you do have a collision which deploys the airbag, any or all of the following may occur:

- The nylon airbag material may sometimes cause abrasions and/or skin reddening to the driver as the airbag deploys and unfolds itself from the steering wheel.

The abrasions are similar to friction rope burns or those you might get sliding along a carpet or gymnasium floor. They are not caused by contact with chemicals. They are not permanent and normally heal quickly. However, if you haven't healed significantly within a few days, or if you have any blistering, see your doctor immediately.

- As the airbag deflates you may see some smoke-like particles. The particles are a normal by-product of the process that generates the non-toxic nitrogen gas used for airbag inflation. These airborne particles may irritate the skin, eyes, nose, or throat. If you have skin or eye irritation, rinse the area with cool water. For nose or throat irritation, move to fresh air. If the irritation continues, see your doctor.

If these particles settle on your clothing, follow the garment manufacturer's instructions for cleaning.

- Your vehicle may be driveable after the airbag deploys. If so, you can tuck the deployed airbag inside the opening in the steering wheel hub trim cover to make driving somewhat easier.

WARNING!

The airbag inflator becomes hot during deployment. To prevent injury, wait at least 15 minutes before tucking a deployed airbag back inside the opening in the steering wheel hub trim cover.

WARNING!

A deployed airbag can't protect you in another collision. Have the airbag replaced by an authorized dealer as soon as possible.

WAR

Being too close to the steering wheel or instrument panel during airbag deployment can cause injury. Airbags need room to inflate. Don't habitually extend your arms or legs toward the steering wheel or instrument panel.

WARNING!

Being too close to the steering wheel or instrument panel during airbag deployment could cause serious injury. Airbags need room to inflate. Sit back, comfortably extending your arms to reach the steering wheel or instrument panel.

Maintaining Your Airbag System**WARNING!**

- Modifications to any part of the airbag system could cause it to fail when you need it. You could be injured because the airbag is not there to protect you. Do not modify the components, including adding any kind of badges or stickers to the steering wheel hub cover. Do not modify the front bumper or vehicle body structure.

If you equip this vehicle with a snow plow, do not expect that the airbag will perform as previously described in this section.

- You need proper knee impact protection in a collision. Do not mount or locate any aftermarket equipment on or behind the knee bolster.
- It is dangerous to repair any part of the airbag system yourself. Don't try to repair any part of the airbag system. Be sure to tell anyone who works on your vehicle that it has an airbag.

ENGINE BREAK-IN RECOMMENDATIONS

Your new Jeep engine is ready for the road. To provide the longest engine life, follow these guidelines for the first few hundred miles (or kilometers).

- Check the fluid and engine oil levels regularly and be alert for indications of overheating in any component of the vehicle. Engines tend to use more fuel and oil until they are broken in, so don't expect top economy for the first 1,200 miles (1 900 km).
- After starting a cold engine, let it warm up for 15 seconds or so before shifting into gear.
- Drive at varying speeds below 50 mph (80 km/h) for first 100 miles (160 km) and below 55 mph (88 km/h) for first 500 miles (800 km). Avoid driving at full throttle or top speeds, steady speeds, or excessive idling during this period. Avoid fast starts and quick stops.

- Allow proper break-in, at least 1,200 miles (1 900 km), before requesting engine adjustments.
- A break-in oil is not used. The original engine oil is the same type specified for regular oil changes. There is no need to have it changed or the oil filter replaced until the first scheduled maintenance interval except in heavy-duty operation. Don't add anti-friction compounds or special break-in oils during the first few thousand miles (or kilometers) of operation, since these additives might interfere with proper piston ring seating.

NOTE: Maintaining proper fluid levels is particularly important during the break-in period. Refer to the Service and Maintenance section for checking fluid levels.

CHECKING YOUR VEHICLE

Exhaust Gas

WA

Exhaust gases can injure you. Carbon monoxide (CO) which is invisible and odorless. Breathing it can make you dizzy, nauseous, and eventually poison you. Always follow the safety tips below.

- Do not run the engine in enclosed areas any longer than necessary. Run the engine out of the area.
- If it is necessary to sit in the vehicle with the engine running, adjust the controls to force outside air into the vehicle at high speed.

CHECKING YOUR VEHICLE FOR SAFETY

Exhaust Gas

WARNING!

Exhaust gases can injure or kill. They contain carbon monoxide (CO) which is colorless and odorless. Breathing it can make you unconscious and can eventually poison you. To avoid breathing (CO) follow the safety tips below.

- Do not run the engine in a closed garage or in confined areas any longer than needed to move your vehicle in or out of the area.
- If it is necessary to sit in a parked vehicle with the engine running, adjust your heating or cooling controls to force outside air into the vehicle. Set the blower at high speed.

- Do not inhale exhaust gases. They contain carbon monoxide, a colorless and odorless gas which can kill. Never run the engine in a closed area, such as a garage, and never sit in a parked vehicle with the engine running for an extended period. If the vehicle is stopped in an open area with the engine running for more than a short period, adjust the ventilation system to force fresh, outside air into the vehicle.
- Guard against carbon monoxide with proper maintenance. Have the exhaust system inspected every time the vehicle is raised. Have any abnormal conditions repaired promptly. Until repaired, drive with all side windows fully open.
- Always open the fresh air vents when driving with any windows open, even if only slightly, to help keep fresh air circulating inside vehicle. Otherwise, poisonous exhaust gases could be drawn into the vehicle.

- Keep the liftgate closed when driving your vehicle to prevent carbon monoxide and other poisonous exhaust gases from entering the vehicle.

WARNING!

If you are required to drive with the liftgate open, make sure that all windows are closed, and the climate control blower switch is set at high speed. Do NOT use the recirculation mode.

Safety Checks You Should Make Inside the Vehicle

Seat Belts

Inspect the belt system periodically, checking for cuts, frays and loose parts. Damaged parts must be replaced immediately. Do not disassemble or modify the system.

Seat belt assemblies must be replaced after an accident if they have been damaged (bent retractor, torn webbing, etc.). If there is any question regarding belt or retractor condition, replace the belt.

Defrosters

Check operation by selecting the defrost mode and place the blower control on high speed. You should feel the air directed against the windshield.

Safety Checks You Should Make Outside the Vehicle

Tires

Examine tires for excessive tread wear or uneven wear patterns. Check for stones, nails, glass, or other objects lodged in the tread. Inspect for tread cuts or side wall cracks. Check wheel nuts for tightness and tires (including spare) for proper pressure.

Lights

Have someone observe the lights while you work the controls. Check the beam indicator lights on the

Fluid Leaks

Check area under vehicle for fuel, water, oil or other fluid leaks. If any are detected, the cause should be corrected immediately.

Lights

Have someone observe the operation of all exterior lights while you work the controls. Check turn signal and high beam indicator lights on the instrument panel.

Fluid Leaks

Check area under vehicle after overnight parking for fuel, water, oil or other fluid leaks. Also, if gasoline fumes are detected, the cause should be located and corrected immediately.

UNDERSTA

CONTENTS

- Keyless Entry System
- Windows
 - Pop-Out Quarter Wind
2-Door Models
 - Power Windows
- Seats
 - Front Seat Adjustment
 - Front Seat Adjustment
 - Seatback Release, 2-Do
 - Headrests

UNDERSTANDING THE FEATURES OF YOUR VEHICLE

CONTENTS

■ Keyless Entry System	36	□ Six-Way Power Seat	41
■ Windows	37	□ Fold-Down Rear Seat	42
□ Pop-Out Quarter Window Vents — Cherokee 2-Door Models	37	□ Rear Seat Cushion Removal	43
□ Power Windows	38	■ Mirrors	44
■ Seats	38	□ Inside Day/Night Mirror	44
□ Front Seat Adjustment	39	□ Outside Mirrors	45
□ Front Seat Adjustment — Recline	39	□ Power Remote Control Dual Outside Rearview Mirrors	46
□ Seatback Release, 2-Door Models	40	□ Lighted Vanity Mirror	46
□ Headrests	40	■ Lights	47

34 UNDERSTANDING THE FEATURES OF YOUR VEHICLE

- Light Switch 47
- Headlight Beam Switch 48
- Passing Light 48
- Sentinel Headlight Switch 48
- Headlight Reminder 48
- Daytime Running Lights (Canada Only) 49
- Front Interior Reading Lights—Optional 50
- Cargo Area Light—Optional 50
- Multifunction Control Lever 51
 - Turn Signals 51
 - Windshield Wipers And Washers 51
- Tilt Steering Column 53
- Rear Window Features 54
 - Rear Window Wiper And Washer 54
 - Rear Window Defogger 54
 - Electronic Speed Control 55
 - To Activate 56
 - To Set At A Desired Speed 56
 - To Deactivate 56
 - To Resume Speed 56
 - To Vary The Speed Setting 56
 - To Accelerate For Passing 57
 - Driving Up Or Down Hills 57
 - Overhead Console 58
 - Cup Holder 61
 - Glove Box 61
- Cigarette Lighter And A
- To Open And Close The

UNDERSTANDING THE FEATURES OF YOUR VEHICLE 35

■ Cigarette Lighter And Ashtray 61
■ To Open And Close The Hood 62

■ Roof Rack 64
■ Cargo Tie Down Hooks 66

KEYLESS ENTRY SYSTEM

The Keyless Entry System enables you to lock or unlock all the doors from a position outside the vehicle.

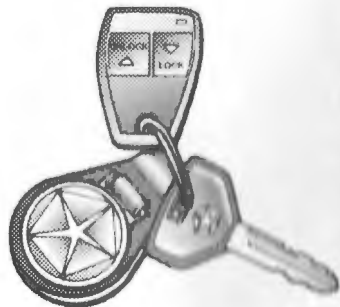

0010014

Operate the system by holding the key ring transmitter close to the side of the vehicle. Point it at the receiver located above the windshield and between the sunvisors or at the rear of the overhead console. Press the finger pad to lock or unlock the doors.

The indicator light glows when the unit is operating to show that the transmitter batteries are OK. Battery life is approximately one year. Replace the batteries in the

transmitter with two CR1616 3-volt batteries. Batteries must be installed correctly. The polarity, "+" or "-", is engraved on the case.

NOTE: The transmitter can be damaged if struck sharply. Do not drop or throw keys with transmitter attached.

The Keyless Entry transmitter is programmable:

1. Sit inside the vehicle and close all of the doors.
2. Place ignition in the OFF position.
3. Open the driver's door and leave open during programming procedure.
4. Move the mechanical door lock lever to the LOCK position.
5. Turn ignition to the RUN position.

6. Aim the transmitter at the receiver and press the LOCK button.

7. Hold the button until the indicator light blinks twice. The door locks.

8. Turn ignition OFF with the key.

9. Check receiver memory by pressing the transmitter. Up to 4 doors can be programmed into a vehicle.

6. Aim the transmitter at the Keyless Entry receiver and press the LOCK button.
7. Hold the button until the light on the transmitter blinks twice. The door locks will cycle.
8. Turn ignition OFF within 20 seconds.
9. Check receiver memory by cycling the door locks using the transmitter. Up to four transmitters may be programmed into a vehicle.

WINDOWS

Pop-Out Quarter Window Vents — Cherokee 2-Door Models

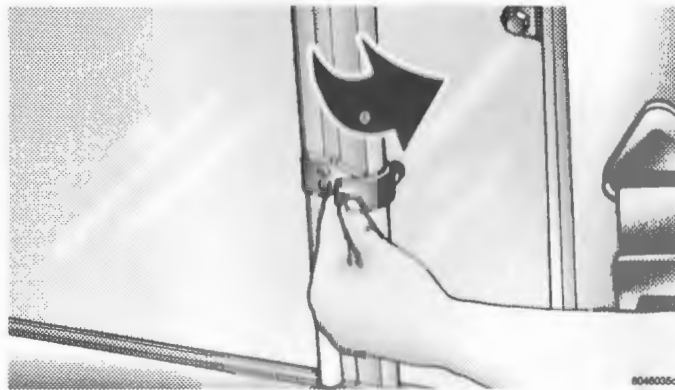

To open the pop-out vent, pull the latch forward until it locks in the open position. To close, pull latch from open position, then push rearward until latch locks in closed position.

Power Windows

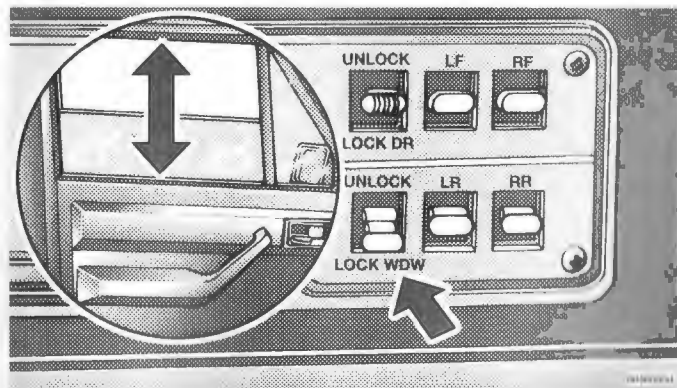

As a child safety precaution, power windows operate with the ignition switch in the ON position only. An individual button controls each side window. Press button down to lower a window, press up to raise it. A set of

buttons on the driver's door provides remote control of all side windows. A lockout control (A) allows only the driver to operate the windows.

SEATS

WARNING!

Adjusting a seat while the vehicle is moving is dangerous. The sudden movement of the seat could cause you to lose control. The seat belt might not be properly adjusted and you could be injured. Adjust any seat only while the vehicle is parked.

Front Seat Adjustment

Move seat forward or rear the adjuster bar upward position. Be sure the latch

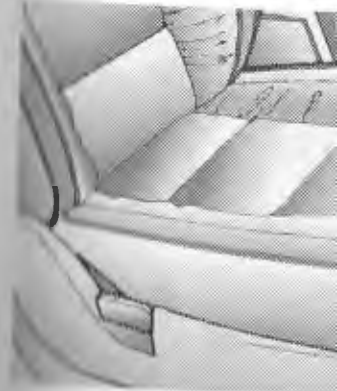

Front Seat Adjustment

Move seat forward or rearward using adjuster bar. Pull the adjuster bar upward and move seat to desired position. Be sure the latch engages fully.

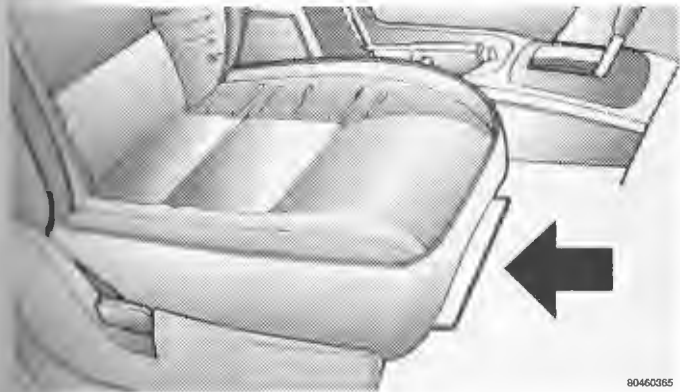

Front Seat Adjustment — Recline

To adjust seatback, lift lever, lean back, and release lever at desired position. To return seatback, lift the lever, lean forward and release the lever.



3

WARNING!

Do not ride with the seatback reclined so that the shoulder belt is no longer resting against your chest. In a collision you could slide under the seat belt and be seriously or even fatally injured. Use the recliner only when the vehicle is parked.

Seatback Release, 2-Door Models

Lift the lever up to fold the seatback forward. When the seatback is returned to the upright position, make sure it is latched by trying to move the seatback without lifting the lever.

Headrests

Move the headrests up or down to adjust to the correct height for driver and passenger.

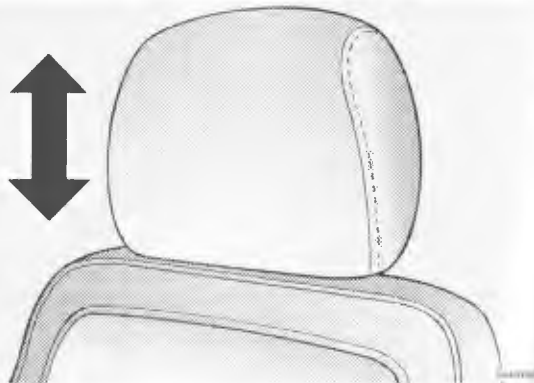

Headrests provide better protection when adjusted to the back of your head, not to the back of your neck.

Six-Way Power Seat

A control is mounted on the seat.



Six-Way Power Seat

A control is mounted on the outboard side of the driver's seat.

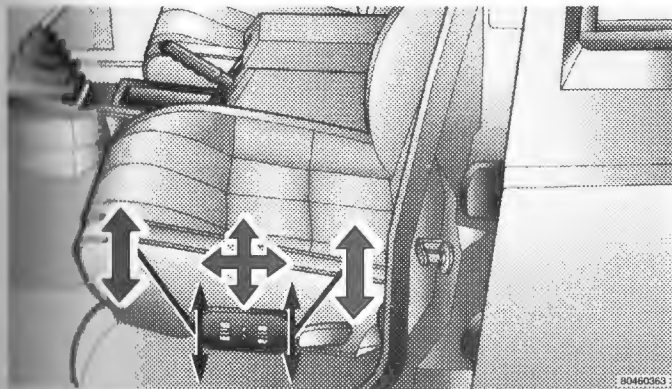

- To raise/lower seat: Move center control upward or downward.
- To move seat forward/rearward: Move center control forward/rearward.
- To tilt front of seat upward/downward: Move front control upward or downward.
- To tilt rear of seat upward/downward: Move rear control upward/downward.

3

CAUTION!

Don't put anything under a power seat. It may cause damage to the seat controls.

Fold Down Rear Seat

To expand cargo area:

1. Pull either side loop;
2. Pivot seat cushion forward;

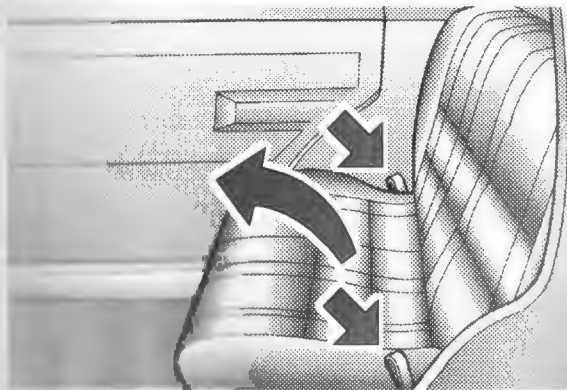

3. Release the lock at either side of seatback;

4. Fold the seatback flat.

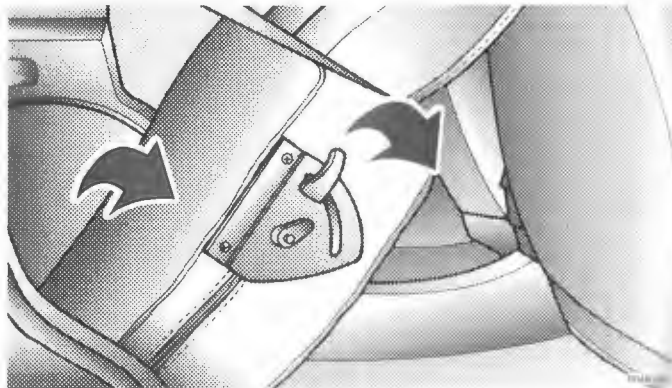

To carry passengers, place the seatback in the upright position and latch it securely. Fold the seat cushion into place and be sure seat belts are placed where they can be used.

Rear Seat Cushion Removal

To lengthen the cargo area:

- Pull the passenger-side latch;
- Pull up on pivot release from pivot.

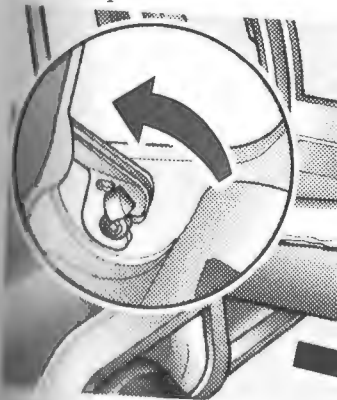

How Seat Cushion Removal

to lengthen the cargo area:

- Pull the passenger-side loop to release the cushion.
- Pull up on pivot release lever and remove cushion from pivot.

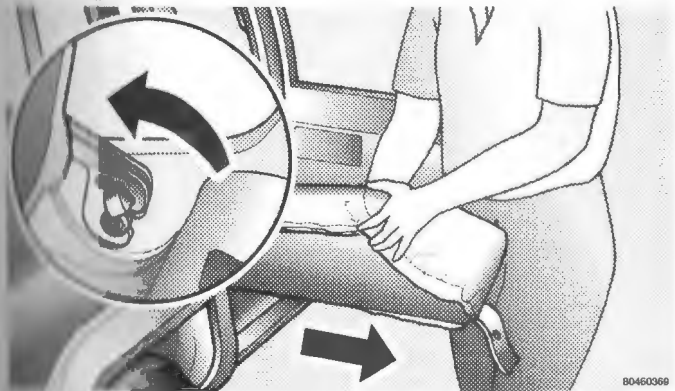

- Carefully pull cushion toward you until pin is removed from pivot on driver's side.
- Remove cushion.
- Reverse the procedure to replace the cushion.

WARNING!

It is extremely dangerous to ride in a cargo area, inside or outside of a vehicle. In a collision, people riding in these areas are more likely to be seriously injured or killed.

Do not allow people to ride in any area of your vehicle that is not equipped with seats and seat belts.

Be sure everyone in your vehicle is in a seat and using a seat belt properly.

MIRRORS

Inside Day/Night Mirror

The mirror should be adjusted to center on the view through the rear window. A two point pivot system allows for horizontal and vertical adjustment of the mirror.

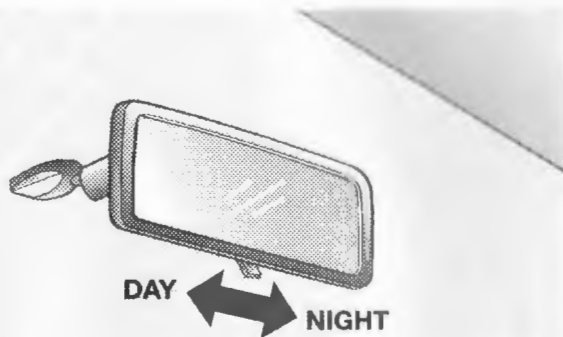

8000b8e7

Annoying headlight glare can be reduced by moving the small control under the mirror to the night position (toward rear of vehicle). The mirror should be adjusted while set in the day position (toward windshield).

Outside Mirrors

To receive maximum benefit to center on the adjacent overlap of the view obtained

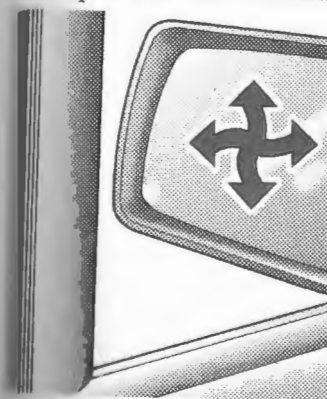

Outside Mirrors

To receive maximum benefit, adjust the outside mirror(s) to center on the adjacent lane of traffic with a slight overlap of the view obtained on the inside mirror.

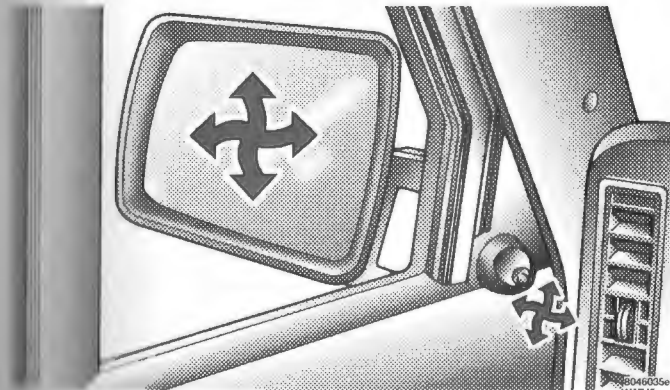

WARNING!

Vehicles and other objects seen in the right side convex mirror will look smaller and farther away than they really are. Relying too much on your right side mirror could cause you to collide with another vehicle or other object. Use your mirror when judging the size or distance of a vehicle seen in the right side mirror.

Power Remote Control Dual Outside Rearview Mirrors

The controls are located next to the driver on the front of the armrest/storage compartment.

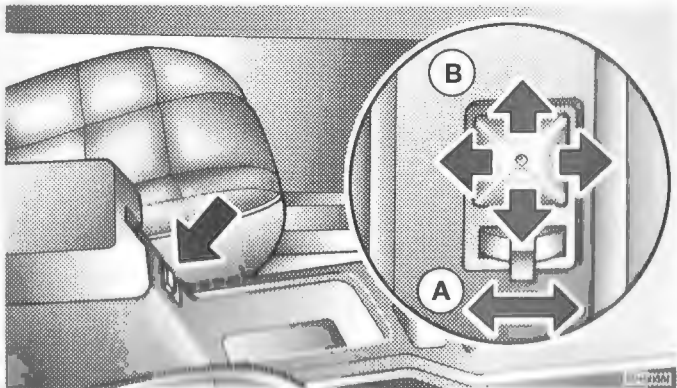

Set Selector Switch (A) for right or left mirror. Then move directional control button (B) to adjust setting of outside rearview mirror. Move Selector Switch to the center position for OFF.

Lighted Vanity Mirror

Lift the cover to reveal the mirror. The light will turn on automatically. Sliding the button up or down will vary the intensity of the light.

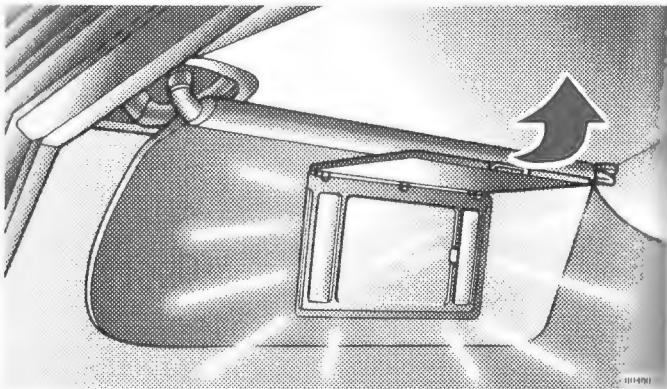
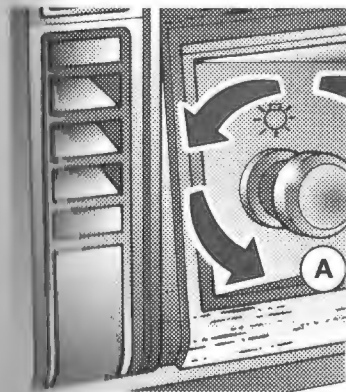
**LIGHTS****Light Switch**

LIGHTS

Light Switch

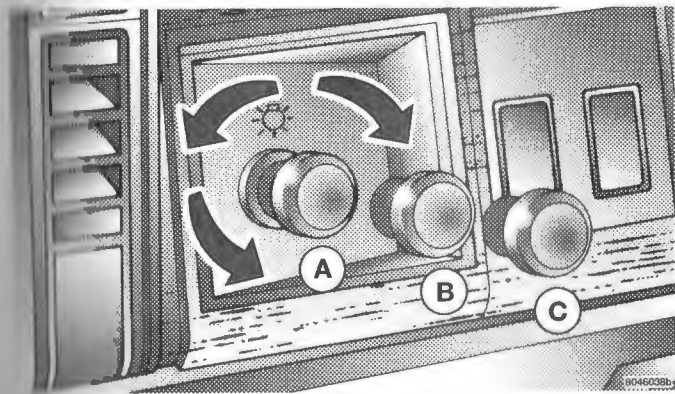
*Off*

Push the switch all the way in (A).

Parking Lights And Instrument Lights

Pull the switch halfway out (B).

Headlights On

Pull the switch all the way out (C)

Instrument Cluster Lights Intensity Control

Turn the knob to the right to dim instrument lights, turn it to the left to brighten instrument lights. Turn the knob fully to the left to turn on overhead and courtesy lights.

Headlight Beam Switch

When the headlight switch is ON, pull the multifunction stalk toward you. The headlights will change from low-beam to high-beam, or from high-beam to low-beam. A high-beam indicator is in the center of the instrument cluster.

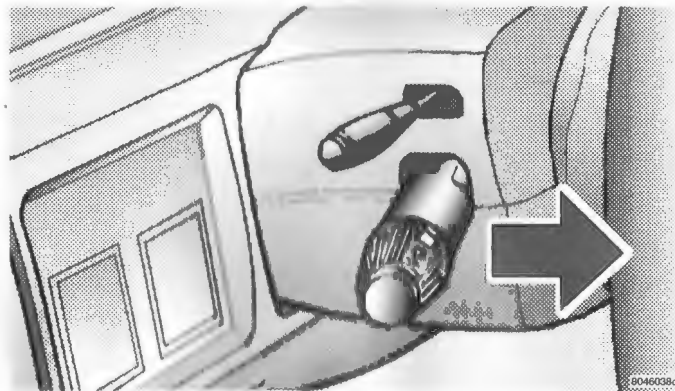

Passing Light

When the headlight switch is OFF, pull the multifunction stalk toward you and hold. High-beam will be activated and releasing the stalk will deactivate the lights.

Sentinel Headlight Switch

Turn off the ignition switch, then the headlight switch. On some models, the Sentinel will keep the headlights on for about 45 seconds. Turning the headlights off before turning the ignition switch off deactivates the Sentinel.

The Sentinel Switch may be activated if the multifunction stalk is pulled forward after engine shut-off. The Sentinel will keep the headlamps on for about 45 seconds.

Headlight Reminder

An alarm will sound when the driver's door is opened, if the headlights or parking lights are ON and the ignition is OFF.

Daytime Running Lights

The headlamps on your vehicle are on when the vehicle is started and the engine is running. This provides visibility in low-light conditions until the engine speed drops below 500 RPM and the headlights illuminate at less than 50%.

Fog Lamps



Daytime Running Lights (Canada Only)

The headlamps on your vehicle will illuminate when the vehicle is started and the speed sensor recognizes forward motion. This provides a constant "Lights On" condition until the engine is turned OFF. The lamps illuminate at less than 50% of normal intensity.

Fog Lamps

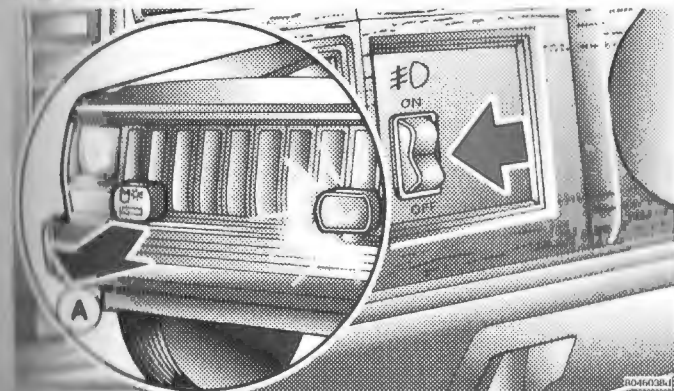

Fog lamps may be operated when the parking lights or low beam headlights are on. If the headlights are switched to high beam, the low beam lamps and the fog lamps will go off. The fog lamps will go back on when the high beams are switched off.

The fog lamp indicator light will go off when the high beams are on, and go back on when the high beams are switched off.

3

WARNING!

Do not operate fog lamps in the face of oncoming traffic. These lamps are intended for use when visibility is limited and the intense brightness may cause excessive glare for other drivers.

Front Interior Reading Lights—Optional

The driver and passenger Reading Lights operate by pressing the corresponding button. Press again to turn them off.

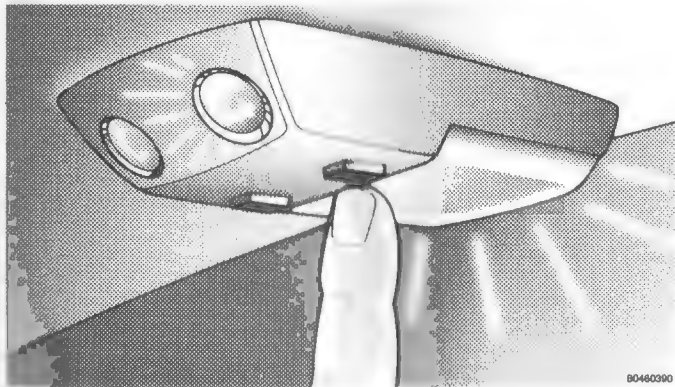

B0460390

Cargo Area Light—Optional

The button on the cargo area light controls the courtesy lights only when all the doors are closed and the liftgate is opened. Normally all the courtesy lights go ON when the liftgate is opened. If you do not want them ON, push the button. Push again for normal operation.

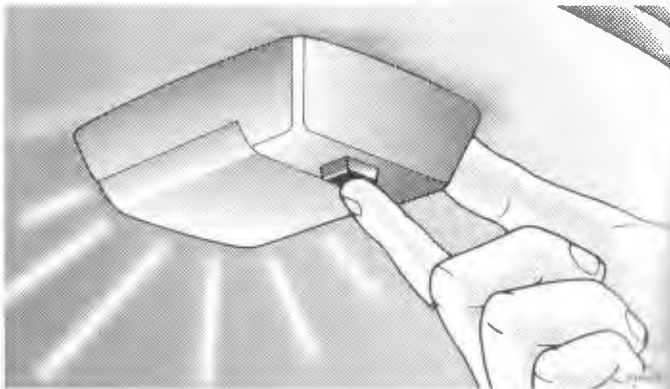

MULTIFUNCTION CONTR

Turn Signals

Move the multifunction stalk in the direction of the turn.

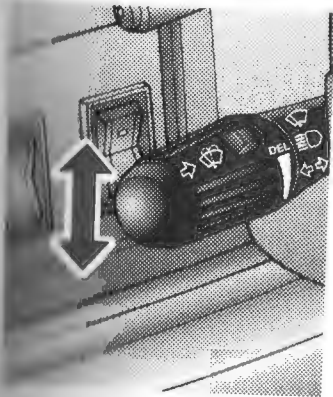

We can signal a lane change normally up or down.

MULTIFUNCTION CONTROL LEVER

Turn Signals

Move the multifunction stalk up or down, depending on the direction of the turn.

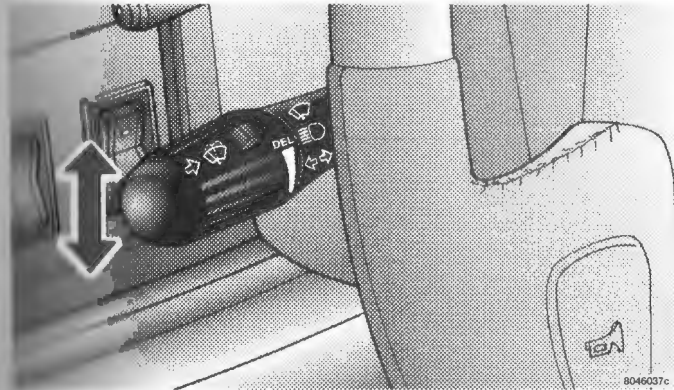

You can signal a lane change by moving the lever partially up or down.

Windshield Wipers And Washers

The wipers and washers are also operated by a switch in the control lever. Rotate the end of the handle to select the desired wiper speed. The washers are activated when the end of the handle is pushed toward the steering column.

3

WARNING!

Sudden loss of visibility through the windshield could lead to an accident. You might not see other vehicles or other obstacles. To avoid sudden icing of the windshield during freezing weather, warm the windshield with the defroster before and during windshield washer use.

NOTE: In cold weather, always turn off the wiper motor and allow the wipers to return to the park position before turning off the engine. If the wiper switch is left on and

the wipers freeze to the windshield, damage to the wiper motor may occur when the vehicle is restarted.

Intermittent Wiper System

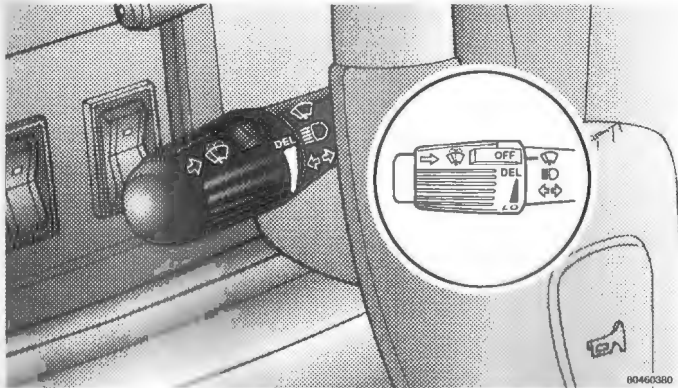

The intermittent feature of this system was designed for use when weather conditions make a single wiping cycle, with a variable pause between cycles, desirable. For

maximum delay between cycles, rotate the control knob into the upper end of the delay range. The delay interval decreases as you rotate the knob until it enters the LO continual speed position. The delay can be regulated from a maximum of approximately 20 seconds between cycles, to a cycle every 2 seconds.

To use the washer, press the knob in and hold as long as spray is desired. If the knob is depressed while in the delay range, the wiper will operate for several seconds after the knob is released, and then resume the intermittent interval previously selected. If the knob is depressed while in the OFF position, the wiper will activate. Upon release of the 'Wash' button, the wipers will complete approximately three wipe cycles and then automatically return to the "Park" position.

When spraying windshield while the intermittent wiper is in operation, the wipers will cycle at low speed until the paddle is released. Then the intermittent function will resume.

TILT STEERING COLUMN

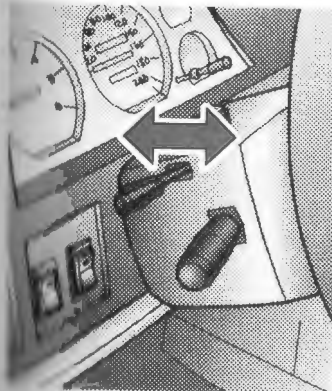

For ease of entry and exit comfort:

1. Pull steering column release lever.
2. Move the steering wheel

TILT STEERING COLUMN

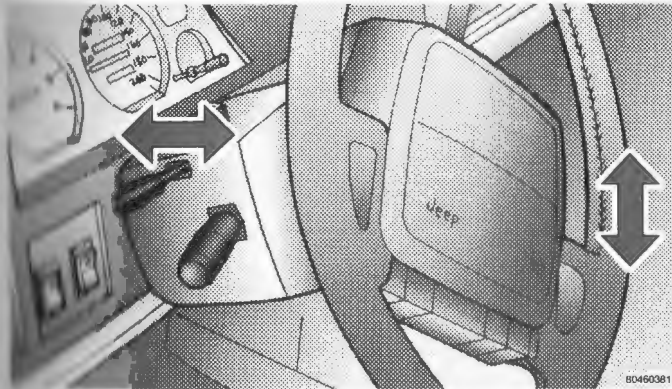

for ease of entry and exit, or to adjust for driving comfort.

1. Pull steering column release lever toward you.
2. Move the steering wheel up or down.

3. Release the lever to lock the wheel firmly in place.

WARNING!

Tilting the steering wheel column while the vehicle is moving is dangerous. Without a stable steering column, you could lose control of the vehicle and have an accident. Adjust the tilting mechanism only while the vehicle is stopped. Be sure it is locked before driving.

REAR WINDOW FEATURES

Rear Window Wiper And Washer

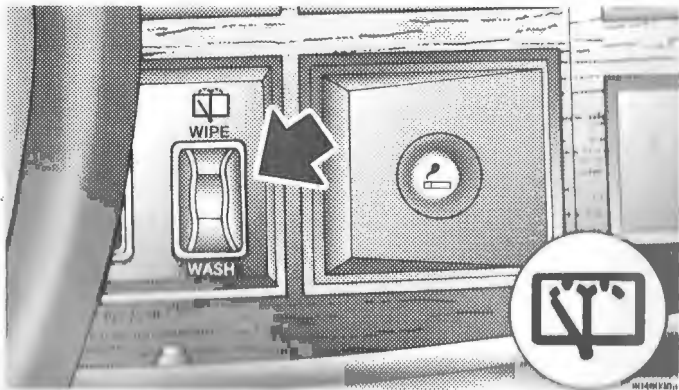

Push the rocker switch to WIPE for wiper operation. The wiper will be intermittent at fixed intervals.

Push and hold the switch to WASH for wiper/washer operation. Release the switch to stop.

Rear Window Defogger

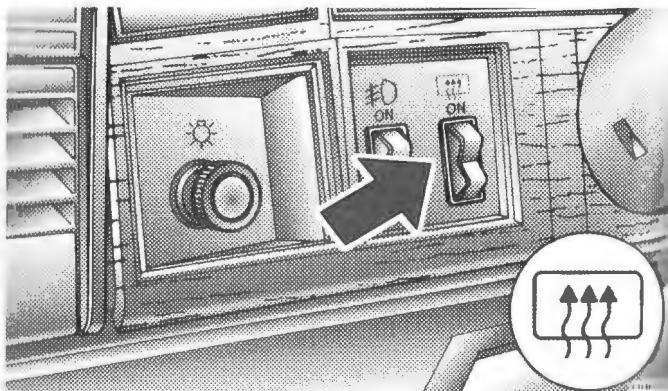

To defog rear window, press the top of the rocker switch. If you press the switch a second time, you will turn the defogger off. A light on the rocker switch will indicate the defogger is on.

The defogger will automatically operate for ten minutes. For additional operation, push the rocker switch. To prevent excessive battery drain, use the defogger only when the engine is operating.

CAUTION

Use care when washing the rear window to prevent damage to the defogger. Use a soft cloth and a mild detergent. Wash parallel to the heating elements. Keep objects a safe distance from the defogger to avoid damaging the heating elements.

The defogger will automatically turn off after approximately ten minutes. For approximately five more minutes of operation, push the switch again. To prevent excessive battery drain, use the defogger only when the engine is operating.

CAUTION!

Use care when washing the inside of the rear window to prevent damage to heating elements. Use a soft cloth and a mild washing solution, wiping parallel to the heating elements. Also, keep all objects a safe distance from the window to prevent damaging the heating elements.

ELECTRONIC SPEED CONTROL

When engaged, this device takes over the accelerator operations at speeds greater than 35 mph (60 km/h). The controls are mounted on the steering wheel and consist of ON/OFF, Resume/Accel and Set/Decel Controls.

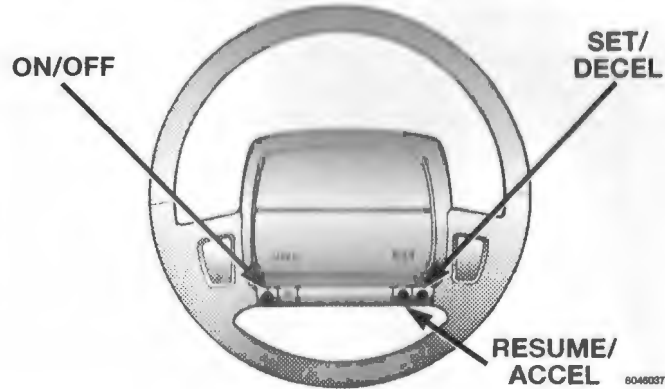

To Activate

Push the ON/OFF switch to the ON position. A light next to the switch will illuminate showing the Electronic Speed Control is ON. To turn the system OFF, push the ON/OFF button again and the system and light will turn OFF. The system should be turned OFF when not in use.

To Set At A Desired Speed

When the vehicle has reached the desired speed, press and release the SET/DECEL button. Release the accelerator and the vehicle will operate at the selected speed.

To Deactivate

A soft tap on the brake pedal or normal brake or clutch pressure while slowing the vehicle will deactivate speed control without erasing the memory. Pushing the ON/OFF to the OFF position or turning off the ignition erases the memory.

To Resume Speed

To resume a previously set speed, push and release the RESUME/ACCEL button. Resume can be used at any speed above 30 mph (50 km/h).

To Vary The Speed Setting

When the speed control is ON, speed can be increased by pressing and holding the RESUME/ACCEL button. When the button is released, a new set speed will be established.

Tapping the RESUME/ACCEL button once will result in a 2 mph speed increase. Each time the button is tapped, speed increases, so tapping the button three times will increase speed by 6 mph, etc.

To decrease speed while speed control is ON, press and hold the SET/DECEL button. Release the button when the desired speed is reached, and the new speed will be set.

To Accelerate for Passing
Depress the accelerator as the pedal is released, the speed.

NOTE: When driving uphill, or when the vehicle is (when towing) the vehicle may if the vehicle speed drops, control will automatically and you can push down on the a the desired speed.

Vehicles equipped with a 5 should be operated in 4th gear.

To Accelerate for Passing

Depress the accelerator as you would normally. When the pedal is released, the vehicle will return to the set speed.

NOTE: When driving uphill, at elevations above 2,000 ft., or when the vehicle is heavily loaded (especially when towing) the vehicle may slow below the SET speed. If the vehicle speed drops below 30 mph the speed control will automatically disengage). If this happens, you can push down on the accelerator pedal to maintain the desired speed.

Vehicles equipped with a 5 speed manual transmission should be operated in 4th gear under the above conditions.

WARNING!

Leaving the Speed Control ON when not in use is dangerous. You could accidentally set the system or cause it to go faster than you want. You could lose control and have an accident. Always leave the system OFF when you aren't using it.

Driving Up or Down Hills

When going up or down hills, it is possible for your vehicle to lose or gain speed, even though the Speed Control is engaged. If going down a hill steep enough to cause the vehicle to gain speed, press the brake pedal, which will disengage the Speed Control and help slow your vehicle.

With a manual transmission vehicle, downshift to a lower gear if the vehicle cannot maintain set speed while going up hills.

WARNING!

To help keep your vehicle under control, do not use Speed Control under these conditions:

- When it is not possible to keep your vehicle at a set speed.
- On slippery roads, such as on snow or ice
- In heavy or varying traffic volume, in traffic that varies in speed, or on winding roads.
- Be sure to turn the Speed Control switch to the OFF position when not in use to avoid accidental engagement.

OVERHEAD CONSOLE

The Console houses these components:

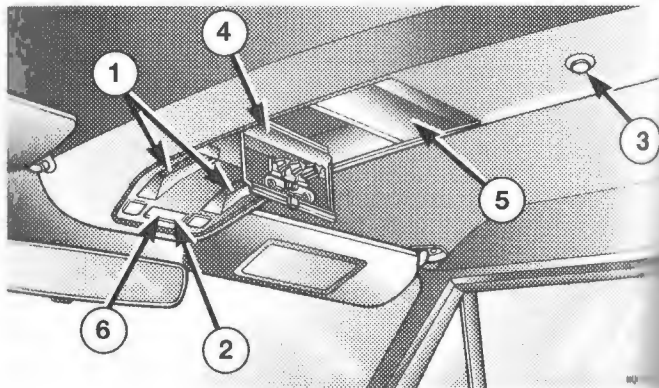

1. Reading lights for front and rear seating areas. The lamps have independent on-off switches. Rear lamps also operate as Courtesy lamps.

NOTE: Lamps will remain on for 10 minutes after the vehicle is shut off. Turn the lamps off before leaving the vehicle.

2. Digital display for compass, odometer, and trip measurement. Press the right arrow to turn the display ON/OFF. Press U.S. or MILES on the right of display for degrees.

3. Keyless Entry Receiver. To activate, point transmitter to the side of the vehicle, point towards the receiver. Transmitter will lock.

4. Holder for automatic garage door opener.

5. Position opener in desired position. Fastener provided.

6. Select one of the three positioners based on thickness of transmitter. Use the medium tab for thicker transmitters and the thin tab for thinner transmitters.

NOTE: Lamps will remain on until switch is pressed, so check before leaving the vehicle.

7. Digital display for compass and outside air temperature measurement. Press Comp/Temp button to turn display ON/OFF. Press U.S./Metric button located to the right of display for degrees Fahrenheit or Celsius.

8. Keyless Entry Receiver - Hold transmitter near the side of the vehicle, point toward the receiver and press to activate. Transmitter will lock or unlock all doors at once.

9. Holder for automatic garage door opener.

a. Position opener in designated space using velcro fastener provided.

b. Select one of the three pegs located inside the holder cover based on thickness of your transmitter. Use medium tab for transmitter 1-1/8" thick. Use longer tab for thinner transmitter and shorter tab for a thicker one.

c. Slide chosen tab between two prongs located on door cover until it clicks into place.

d. Line up the button on transmitter with the tab.

e. You can now operate your garage door by pressing on the closed holder cover.

5. Holder for sunglasses — Push to release cover.

6. Compass indicates forward direction of vehicle.

a. Calibration

This compass is self-calibrating which eliminates the need to manually set the compass. For a short time when the vehicle is new, the compass may appear erratic and the CAL symbol will be displayed. After completing, at most, three 360 turns, the CAL symbol will turn off and the compass will function normally.

b. Variance

Variance is the difference between magnetic North and geographic North. In some areas the difference between magnetic and geographic north is great enough to cause the compass to give false readings. If this occurs, the variance must be set.

To set the variance: turn the ignition switch ON, depress and hold the Comp/Temp button located to the left of the display, then depress and hold the U.S./Metric button located to the right for approximately 5 seconds. The VAR symbol will be displayed and all other symbols will be off. Release the buttons.

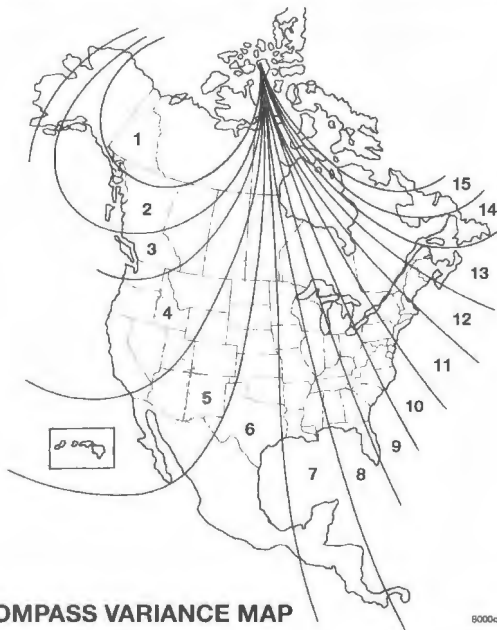

COMPASS VARIANCE MAP

8000chale

Consult the map to determine your geographic location. To set the variance, press the U.S./Metric button to step through the appropriate variance number. Then press the Comp/Temp button. The display will go blank, then return after approximately 5 seconds and will be blank.

NOTE: Do not attach magnetic CB antennas to the vehicle. This will cause the compass to give false readings.

CUP HOLDER

Your Jeep Cherokee is equipped with a cup holder. The holder can be found in the front of the floor console. The holder is made of molded plastic and can accommodate most cans or the equivalent.

Consult the map to determine the variance number for your geographic location. To set the variance, press the U.S./Metric button to step through the numbers until the appropriate variance number appears on the display. Then press the Comp/Temp button to enter this value. The display will go blank, then reappear after approximately 5 seconds and will be functioning normally.

NOTE: Do not attach magnetic devices such as magnetic CB antennas to the vehicle roof as they can cause the compass to give false readings.

CUP HOLDER

Your Jeep Cherokee is equipped with a removable cup holder. The holder can be found in the storage compartment of the floor console. The cup holder is made of molded plastic and can accommodate two 12 oz. beverage cans or the equivalent.

To install the cup holder, insert the two side tabs into the slots provided next to the transmission shifter on the passenger side. When the tabs are fully inserted, reach under the cup holder to locate the support bar. Depress this bar and rotate the cup holder downward to position the bar in the opening provided in the floor console trim panel.

GLOVE BOX

The glove box light will remain on if the glove box door is not securely closed, causing an unnecessary drain on the battery.

CIGARETTE LIGHTER AND ASHTRAY

As a child safety precaution, the lighter only operates with the ignition switch ON. It heats when pushed in and pops out automatically when ready for use.

NOTE: To preserve the heating element, do not hold the lighter element in the heating position.



To remove the ashtray, press down on lever (A) and pull out the tray.

TO OPEN AND CLOSE THE HOOD

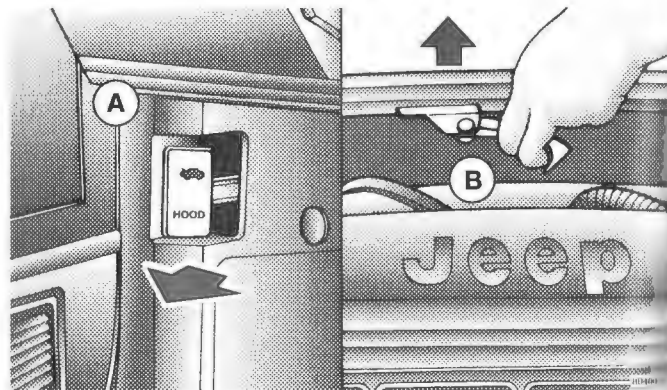

To open hood, pull the release lever (A) inside your vehicle, located below the instrument panel and in front of the driver's door. Then press the safety latch under the hood (B), raise the hood, and insert the support rod into the slot on the hood.

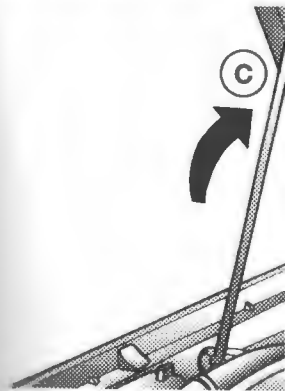

To close the hood, remove the support rod and place it in the retaining slot. Then let it drop the last few inches.

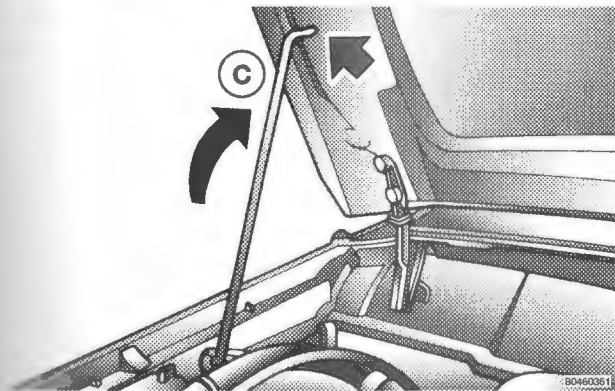

To close the hood, remove the support rod from the hood and place it in the retaining clip. Lower the hood slowly, then let it drop the last few inches.

WARNING!

If the hood is not fully latched, it could fly up when the vehicle is moving and block your forward vision. Be sure all hood latches are latched fully before driving.

ROOF RACK

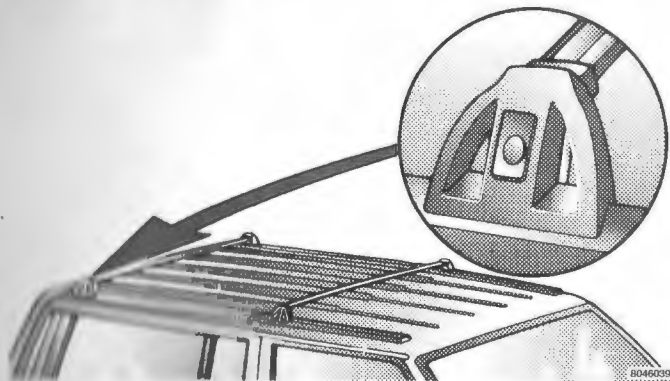

To adjust the crossbars, depress the button to release (lower) holding pin. Slide to the next locking position (approx. 3 inches). Alternate sides until the crossbars are positioned correctly for your cargo and stanchions are locked square to the slide rails.

Distribute cargo weight evenly on the roof rack. Limit the weight to 150 pounds (68 kg). **The roof rack does not increase the total load carrying capacity of the vehicle.** Be sure the total load of cargo inside the vehicle **plus** that on the external rack does not exceed the maximum vehicle load capacity. See load capacities on the vehicle certification label located on the driver's door, below the latch.

CAUTION!

To avoid damage to the roof rack and the vehicle, follow the guidelines below:

- Do not carry more than 150 lbs. (68 kg) of cargo on the roof rack.
- Always distribute heavy loads as evenly as possible and secure the load appropriately.

- Long loads which extend over plywood panels or small boxes on both the front and rear bumper rack. Always travel at reduced speeds carefully when carrying loads on the roof rack. Wind force on objects, can cause damage.
- When crossbars are not installed rearward of the "B" pillar area.
- End caps should not be used unless they are provided at the end of the slide rail.

WARNING!

To prevent possible injury while using the roof rack, follow the guidelines below:

- Always be sure that cargo is securely tied before driving your vehicle. Improperly secured loads are dangerous. They can fly off the vehicle, causing personal injury or property damage. Follow the instructions above when carrying cargo on your roof rack to be sure your load is secured correctly and is not too heavy.
- A too-heavy load can cause an accident. Too much weight in or on your vehicle can seriously change its handling characteristics. You might lose control while driving. Never exceed the vehicle load capacity.

3

- Long loads which extend over the windshield (such as plywood panels or small boats) should be secured to both the front and rear bumpers in addition to the rack. Always travel at reduced speeds and turn corners carefully when carrying large or heavy loads on the roof rack. Wind forces, especially on large flat objects, can cause damage to your cargo and vehicle.
- When crossbars are not in use, they should be positioned rearward of the "B" pillar over the rear compartment area.
- End caps should not be used as hold downs. Tie down holes are provided at the front and rear ends of the slide rail.

CARGO TIE DOWN HOOKS

The tie downs located on cargo area floor should be used to safely secure loads when vehicle is moving.

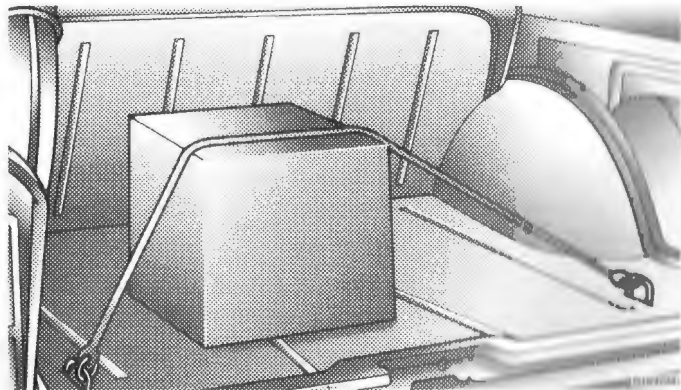

WARNING!

Cargo tie down hooks are not safe anchors for a child seat tether strap. In a sudden stop or collision a hook could pull loose and allow the child seat to come loose. A child could be badly injured. Use only the anchors provided for child seat tethers.

WARN

The weight and position of cargo can change the vehicle center of gravity and affect handling. To avoid loss of control or personal injury, follow these instructions for your vehicle:

- Do not carry loads which exceed the weight described on the label attached to the floor center pillar.
- Always place cargo evenly. Place heavier objects as low and as far from the center of the vehicle as possible.
- Place as much cargo as possible on one side. Too much weight or uneven weight may cause the vehicle to sway.

WARNING!

The weight and position of cargo and passengers can change the vehicle center of gravity and vehicle handling. To avoid loss of control resulting in personal injury, follow these guidelines for loading your vehicle:

- Do not carry loads which exceed the load limits described on the label attached to the left door or left door center pillar.
- Always place cargo evenly on the cargo floor. Put heavier objects as low and as far forward as possible.
- Place as much cargo as possible in front of the rear axle. Too much weight or improperly placed weight over or behind the rear axle can cause the rear of the vehicle to sway.

- Do not pile luggage or cargo higher than the top of the seatback. This could impair visibility or become a dangerous projectile in a sudden stop or collision.

WARNING!

To help protect against personal injury, passengers should not be seated in the rear cargo area. The rear cargo space is intended for load carrying purposes only, not for passengers, who should sit in seats and use seat belts.

UNDERS

CONTENTS

- Instrument Panel And Con
- Instrument Cluster
- Premium Instrument Cluste
- Instrument Cluster Descrip
- Canadian Clusters
- Radio Operation And Cellu
- Sound Systems
- Electronically Tuned AM/F

UNDERSTANDING YOUR INSTRUMENT PANEL

CONTENTS

■ Instrument Panel And Controls	70	■ Electronically Tuned AM/FM Stereo Cassette Radio With Dolby Noise Reduction — Optional . . .	83
■ Instrument Cluster	71	□ Operating Instructions	83
■ Premium Instrument Cluster	72	□ Tips On Using Cassettes	86
■ Instrument Cluster Description	73	□ Cassette Tape And Player Maintenance	86
■ Canadian Clusters	77	■ Climate Controls	87
■ Radio Operation And Cellular Phones	79	□ Heating	87
■ Sound Systems	80	□ Defogging And Defrosting	88
■ Electronically Tuned AM/FM Stereo Radio	80	□ Fresh Air Ventilation	89
		□ Air Conditioning	90

INSTRUMENT PANEL AND CONTROLS

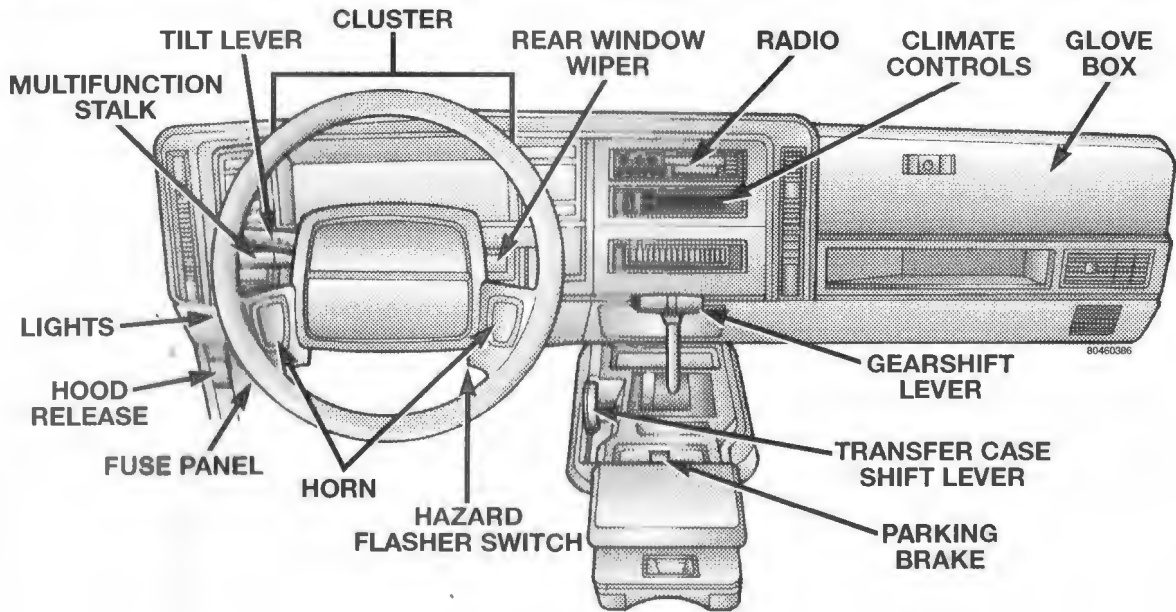

INSTRUMENT CLUSTER

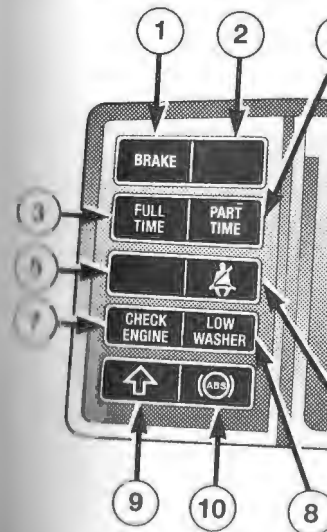

INSTRUMENT CLUSTER

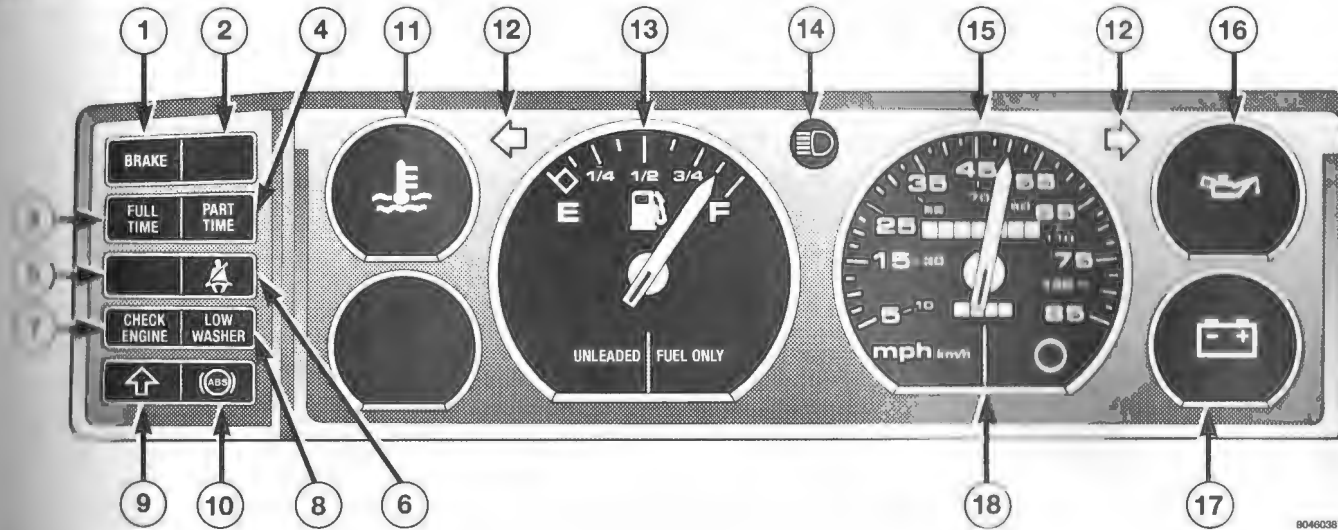

4

PREMIUM INSTRUMENT CLUSTER

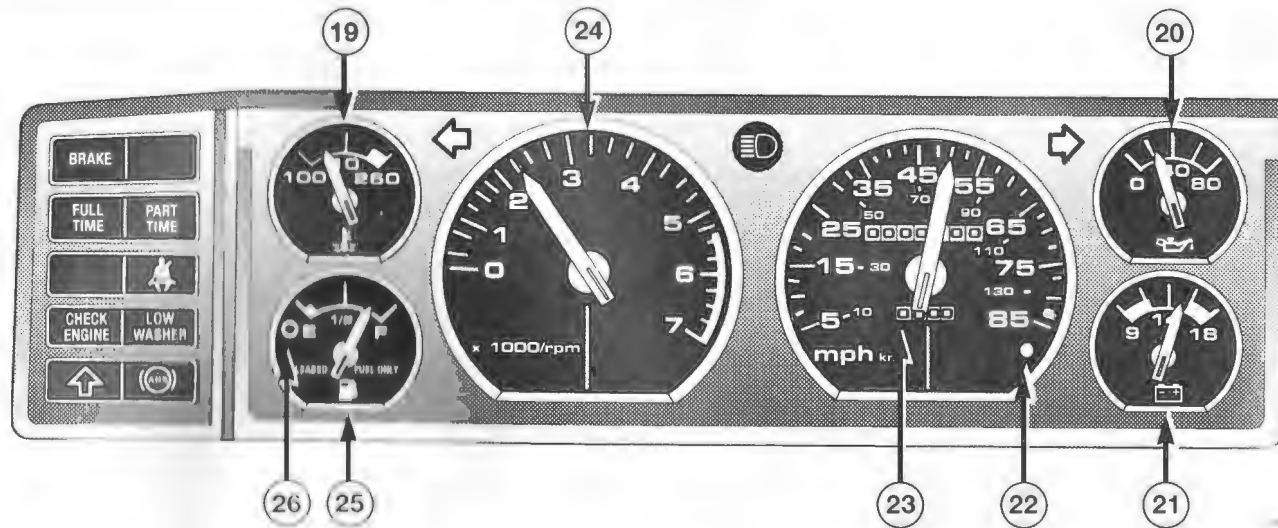

INSTRUMENT CLUSTER

1 Brake and Brake Fluid
Indicates parking brake is
when the parking brake is
brake system fluid leak or
immediately.

Open

Currently not in use.

Full Time 4WD Indicator

Indicates that Selec-Trac is
in 4-wheel drive (4x4 FULL TIME).

Part Time 4WD Indicator

Indicates that Selec-Trac is
in 4-wheel drive (4x4 PART TIME).

The transfer case is in 4-wheel

Open

Currently not in use.

INSTRUMENT CLUSTER DESCRIPTION

1. *Brake and Brake Fluid Pressure Warning Light*

Indicates parking brake is applied. If the light stays on when the parking brake is off, it indicates a possible brake system fluid leak or low pressure level. See your dealer immediately.

2. *Open*

Currently not in use.

3. *Full Time 4WD Indicator Light*

Indicates that Selec-Trac transfer case is in full-time 4-wheel drive (4x4 FULL TIME).

4. *Part Time 4WD Indicator Light*

Indicates that Selec-Trac transfer case is in part-time 4-wheel drive (4x4 PART TIME or 4 LO) or that Command-Trac transfer case is in 4-wheel drive (4H or 4L).

5. *Open*

Currently not in use.

6. *Seat Belt Warning Light*



A warning buzzer and an indicator light will alert you to buckle the seat belts. When the belt is buckled, the buzzer will stop, but the light will stay on until it times out (about 6 seconds).

7. *Check Engine Light*

This light is a part of an onboard diagnostic system called OBD II which monitors the emissions, engine, and automatic transmission control systems. If a problem is detected in one of these systems, the Check Engine Light will come on. Although your vehicle will usually be driveable and not need towing, see your dealer for service as soon as possible.

The light will come on when the ignition is first turned on and stay on briefly as a bulb check. If the bulb does not come on during starting, have the bulb repaired promptly.

CAUTION!

Prolonged driving with the light on could cause further damage to the emission control system. It could also affect fuel economy and driveability. The vehicle must be serviced before any emissions tests can be performed.

If the light is flashing, severe catalytic converter damage and power loss will soon occur. Immediate service is required.

8. Low Windshield Washer Fluid Warning Light

Indicates low fluid level for the windshield and rear window wiper/washers.

9. Shift Indicator Light

 Glows when driver should shift to the next higher gear for best fuel economy. (All manual transmission vehicles.)

10. ABS

 Illuminates to indicate Anti-Lock Brake System self-check is in process at vehicle start-up. If light remains On after start-up or comes On and stays On at road speeds, it may indicate that the ABS has detected a malfunction or has become inoperative. The system reverts to standard non-anti-lock brakes.

Turn the engine Off and On again to reset anti-lock brake system. If light remains On, see your dealer.

If **both** the red brake light and the amber (ABS) light are On, see your dealer immediately. (See Anti-Lock Brake System).

11. Engine Coolant Warning Light

 Indicates possible overheating of engine cooling system. If the light illuminates while driving, stop vehicle and allow system to cool before checking coolant

level. See Cooling System Chapter. See Service and Maintenance section for more information. See immediately.

12. Turn Signal Indicator Light
The arrows will flash in unison with the turn signal, when using the turn

13. Fuel Gauge

 When the ignition key is turned On, the fuel pointer will show the level of fuel in the fuel tank.

14. Headlights High Beam Indicator Light

 This light shows that the high beam is on. Pull the turn signal lever to switch the headlights to low beam.

15. Speedometer

Indicates vehicle speed.

level. See Cooling System Operating Information in the **Service and Maintenance** section. Seek authorized service **immediately**.

11. *Turn Signal Indicator Light*

The arrows will flash in unison with the exterior turn signal, when using the turn signal lever.

12. *Fuel Gauge*

 When the ignition key is in the ON position, the pointer will show the level of fuel remaining in the fuel tank.

13. *Headlights High Beam Indicator Light*

 This light shows that the headlights are on high beam. Pull the turn signal lever toward the steering wheel to switch the headlights from high or low beam.

14. *Speedometer*

Indicates vehicle speed.

16. *Oil Pressure Warning Light*

 Indicates low engine oil pressure. If the light illuminates while driving, check oil level immediately. Do not continue to drive this vehicle when this light is on. See **Service and Maintenance** section.

17. *Generator Warning Light*

 Indicates malfunction in charging system. This light should go off once the engine is started. If it comes on while driving, have the generator drive belt and the charging system checked.

18. *Odometer*

Indicates total distance driven.

19. *Engine Coolant Temperature Gauge*

 Indicates engine coolant temperature. The red zone to the far right indicates possible overheating. Seek authorized service immediately if the gauge operates in the red zone. See Cooling System Operating Information in the **Service and Maintenance** section.

20. Engine Oil Pressure Gauge

 Indicates engine oil pressure. This gauge does not indicate oil level. Normal readings are 20-60 psi (138-414 kPa) in city driving and 45-60 psi (310-414 kPa) at highway speeds. Pressure varies with engine speed, temperature and oil viscosity. Hot engine idle pressure of 13 psi (90 kPa) is satisfactory. Consistent lower readings indicate possible malfunction. Seek authorized service.

21. Voltmeter

 Indicates available battery voltage and charging system operation. The lower red zone indicates that battery charge may be too low to start the engine. With the engine running, the normal operating range is between 11 and 15 volts. Prolonged gauge readings between 9-11 (undercharge) or above 15 (overcharge) indicate possible malfunction of generator, voltage regulator or battery. See your dealer if such indications occur.

22. Trip Odometer Reset Knob

Push button to restart at zero.

23. Trip Odometer

Indicates individual trip mileage.

24. Tachometer

Indicates engine speed in revolutions per minute (RPM)

CAUTION!

Do not operate the engine with tachometer pointer in red area, or engine damage will occur.

25. Fuel Gauge

 When the ignition key is in the ON position, the pointer will show the level of fuel remaining in the fuel tank.

26. Low Fuel Warning Light
Glowing when approximately 1/4 full of the fuel tank.

NOTE: When the ignition is on, fuel gauge, voltmeter, oil pressure gauges may not show accurate readings until the engine is not running, turn the engine off to obtain accurate readings.

CANADIAN CLUSTERS

The instrument cluster in this vehicle has a few exceptions. The Trip Odometer readings measure total mileage. The Oil Pressure Gauge measures engine oil pressure. The level of the gauges is somewhat different.

Low Fuel Warning Light

Glows when approximately 3.6 gallons/11.3L remain in the fuel tank.

NOTE: When the ignition switch is turned to OFF, the fuel gauge, voltmeter, oil pressure and temperature gauges may not show accurate readings. When the engine is not running, turn the ignition switch to ON to obtain accurate readings.

CANADIAN CLUSTERS

The instrument cluster in this vehicle duplicates the U.S. cluster with a few exceptions. The Speedometer and Odometer readings measure kilometers and the Engine Oil Pressure Gage measures bars. The telltale area to the left of the gauges is somewhat different also.

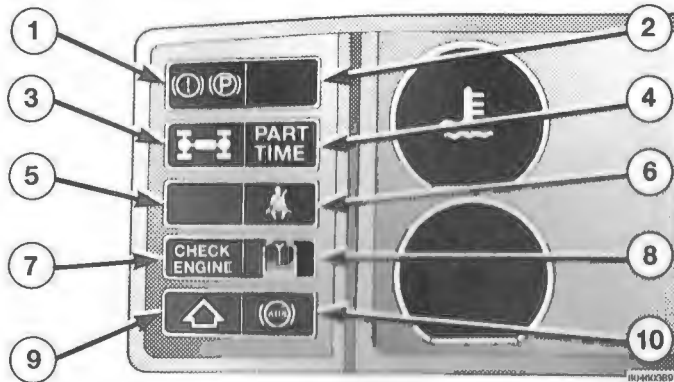

1. Parking Brake And Fluid Pressure Warning Light
 (!) (P) indicates that parking brake is applied. (!) indicates brake system fluid leak or low fluid level. It may be dangerous to continue driving, so see your dealer.

2. Open

Currently not in use.

3. Full Time 4WD Indicator Light

Indicates that Selec-Trac transfer case is in full-time 4-wheel drive (4x4 FULL TIME).

4. Part Time 4WD Indicator Light

Indicates that Selec-Trac transfer case is in part-time 4-wheel drive (4x4 PART TIME or 4 LO) or that Command-Trac transfer case is in 4-wheel drive (4H or 4L).

5. Open

Currently not in use.

6. Seat Belt Warning Light

A warning buzzer and an indicator light will alert you to buckle the seat belts. When the belt is buckled, the buzzer will stop, but the light will stay on until it times out (about 6 seconds).

7. Check Engine Light

This light is a part of an onboard diagnostic system called OBD II which monitors the emissions, engine, and automatic transmission control systems. If a problem is detected in one of these systems, the Check Engine Light will come on. Although your vehicle will usually be driveable and not need towing, see your dealer for service as soon as possible.

The light will come on when the ignition is first turned on and stay on briefly as a bulb check. If the bulb does not come on during starting, have the bulb repaired promptly.

CAUTION!

Prolonged driving with the light on could cause further damage to the emission control system. It could also affect fuel economy and driveability. The vehicle must be serviced before any emissions tests can be performed.

If the light is flashing, severe engine damage and power loss will soon be required.

8. Low Windshield Washer

Indicates low fluid level in windshield wiper/washers.

9. Shift Indicator Light

 Glows when driver shifts into 4th gear for best fuel economy (on 4-cylinder vehicles).

10. ABS

 Illuminates to indicate ABS self-check is in process. If it remains on after start-up or while driving at road speeds, it may indicate ABS malfunction or has become inoperative. Refer to standard non-anti-lock braking system (NABS) to standard non-anti-lock braking system (NABS).

If the light is flashing, severe catalytic converter damage and power loss will soon occur. Immediate service is required.

Low Windshield Washer Fluid Warning Light

Indicates low fluid level for the windshield and rear window wiper/washers.

Shift Indicator Light

 Glows when driver should shift to the next higher gear for best fuel economy. (All manual transmission vehicles).

ABS

 Illuminates to indicate Anti-Lock Brake System self check is in process at vehicle start-up. If light remains On after start-up or comes On and stays On at road speeds, it may indicate that the ABS has detected a malfunction or has become inoperative. The system reverts to standard non-anti-lock brakes.

Turn the engine Off and On again to reset anti-lock brake system. If light remains On, see your dealer.

If both the red brake light and the amber (ABS) check anti-lock light are On, see your dealer immediately. (See Anti-Lock Brake System).

RADIO OPERATION AND CELLULAR PHONES

Under certain conditions, the operation of a cellular phone in your vehicle can cause erratic or noisy performance from your radio. This condition may be lessened or eliminated by relocating the cellular phone antenna. This condition is not harmful to the radio. If your radio performance does not satisfactorily "clear" by the repositioning of the antenna, it is recommended that the radio volume be turned down or off during cellular phone operation.

SOUND SYSTEMS

Your vehicle has one of the following systems. Check to see which one you have and follow the directions that apply to your system.

NOTE: If your radio exhibits erratic memory loss, check under the hood in the Power Distribution Center. Make certain that the IOD fuse (#16) is firmly seated.

ELECTRONICALLY TUNED AM/FM STEREO RADIO

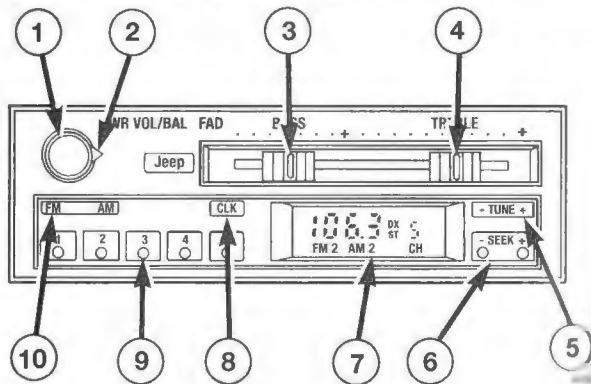

Operating Instructions

1. ON/OFF, Volume and Balance Control

Turn to adjust volume. To adjust left/right speaker balance, pull knob and turn.

2. Fader Control

On vehicles equipped with two speakers, pull knob to adjust front/rear speaker balance.

3. Bass Control

Adjusts the amount of bass.

4. Treble Control

Adjusts the amount of treble.

5. Electronic Tuning Control

Touch to fine tune to the desired frequency on the AM band.

6. Seek

Touch to start search for a station on the AM or FM band.

RADIO



5

3. **Fader Control**

(on vehicles equipped with rear speakers) Adjusts front/rear speaker balance.

4. **Bass Control**

Adjusts the amount of bass heard.

5. **Treble Control**

Adjusts the amount of treble heard.

6. **Electronic Tuning Control**

Touch to fine tune to the next higher (+) or lower (-) frequency on the AM band.

7. **Seek**

Touch to start search for a station higher (+) or lower (-) on the AM or FM band.

7. **Digital Display Screen**

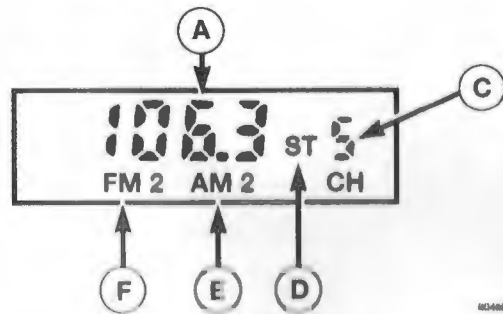

4

(A) Digital Station Display; (C) Pre-selected Station Channel Indicator; (D) Stereo Station Indicator; (E) AM/Double Memory Indicator; (F) FM/Double Memory Indicator.

8. **CLK (Clock)**

The radio display will alternate between the time and the station selected when the CLK button is touched.

Clock SET procedure:

- Depress and hold CLK button until Hours appear, then release CLK button.
- Increase or decrease Hours by pressing TUNE or SEEK buttons (+) or (-).
- Press CLK again to display Minutes.
- Increase or decrease Minutes by pressing TUNE or SEEK buttons (+) or (-).
- Press CLK once more to start the clock.

Each step in the procedure must be completed within 5 seconds or the clock will start and the sequence will have to be repeated.

9. Station Selectors

To program a station into memory:

- Find a desired station using Seek.

- Touch a station selector and hold. The station will cut out, then return. When it returns, release selector.

- After each of the five selectors has programmed one station into memory, a second set of stations can be selected by touching AM or FM a second time. In this way, each selector can program two AM and two FM stations into memory, for a total of 10 AM and 10 FM stations.

10. FM/AM and Double Memory Selector

Touch once to select AM or FM band and first set of pre-selected stations. The Display Screen will indicate Double Memory selection, either FM1 or AM1, as selected. Touch the same side of the switch again to select second set of pre-selected stations. Display Screen will indicate Double Memory selection, either FM2 or AM2 as selected.

ELECTRONICALLY TUNE CASSETTE RADIO WITH REDUCTION — OPTIONAL

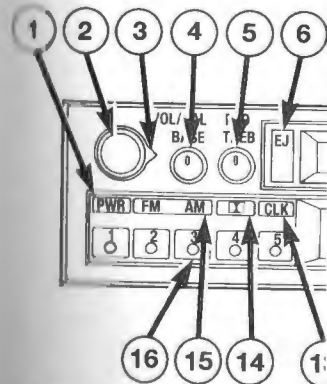

Operating Instructions

1. ON/OFF Switch

This switch furns the system

**ELECTRONICALLY TUNED AM/FM STEREO
CASSETTE RADIO WITH DOLBY NOISE
REDUCTION — OPTIONAL**

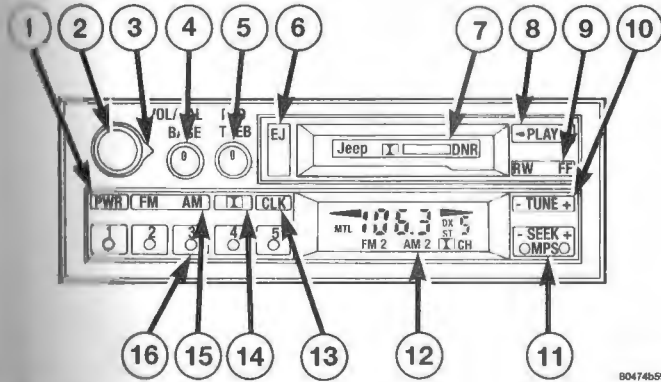

80474b59

Operating Instructions

1. ON/OFF Switch

This switch turns the system ON and OFF.

2. Volume/Balance Control

Turn to adjust volume. To adjust left/right speaker balance, pull knob and turn.

3. Fader Control

Adjusts front/rear speaker balance

4. Bass Control

Press to release knob, then turn to adjust

5. Treble Control

Press to release knob, then turn to adjust.

6. Tape Eject Button

This button ejects the tape.

7. Tape Entry Door

Insert tape here.

8. Program/Play Switch

Touch to reverse tape direction or to stop Fast Forward/Rewind function.

9. Fast Forward/Rewind Switch

Cassette tape function.

10. Electronic Tuning Control

Touch to fine tune to the next higher (+) or lower (-) frequency on the AM band.

11. Seek Control

Touch to start search for the next station higher (+) or lower (-) on the FM or AM band.

Seek/MPS Control — Touch to advance tape to the next or previous tune on a cassette.

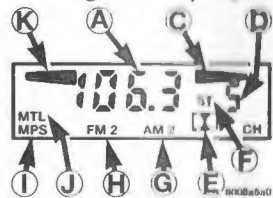
12. Digital Display Screen

Radio and cassette deck function indicators: (A) Digital Program Display; (C) Tape Direction Indicator, Fast Forward when flashing; (D) Pre-selected Station Channel Indicator; (E) Dolby

Noise Reduction Indicator; (F) Stereo Station Indicator; (G) AM/Double Memory Indicator; (H) FM/Double Memory Indicator; (I) Music Program Search Indicator; (J) Metal/CrO₂ Tape Indicator (automatic); (K) Tape Direction Indicator, Rewind when flashing.

13. CLK (Clock)

The radio display will alternate between the time and the station selected when the CLK button is touched.

Clock SET procedure:

- Depress and hold CLK button until Hours appear then release CLK button.
- Increase or decrease Hours by pressing TUNE or SEEK buttons (+) or (-).
- Press CLK again to display Minutes.
- Increase or decrease Minutes by pressing TUNE or SEEK buttons (+) or (-).

e. Press CLK once more.

Each step in the procedure. seconds or the clock will stop to be repeated.

14. Dolby Noise Reduction

Touch when playing a tape. Reduction. The Dolby Noise Reduction will be visible when the Dolby

15. FM/AM and Double Memory

Touch once to select AM or FM. Double Memory selection. The Double Memory selection will be visible. Touch the same side of the second set of pre-selected stations to indicate Double Memory selection.

e. Press CLK once more to start the clock.

Each step in the procedure must be completed within 5 seconds or the clock will start and the sequence will have to be repeated.

14. *Dolby Noise Reduction Switch*

Touch when playing a tape recorded with Dolby Noise Reduction. The Dolby Noise Reduction Indicator (E) will be visible when the Dolby Noise Reduction is active.

15. *FM/AM and Double Memory Selector*

Touch once to select AM or FM band and first set of pre-selected stations. The Display Screen will indicate Double Memory selection, either FM1 or AM1, as selected. Touch the same side of the switch again to select second set of pre-selected stations. Display Screen will indicate Double Memory selection, either FM2 or AM2, as selected.

16. *Station Selectors*

To program a station into memory:

- a. Find desired station by using **Seek** (11).
- b. Touch a station selector and hold. The station will cut out, then return. When it returns, release selector.
- c. After each of the five selectors has programed one station into memory, a second set of stations can be selected by touching AM or FM a second time. In this way, each selector can program two AM and two FM stations into memory, for a total of 10 AM and 10 FM stations.

- Noise Reduction system manufactured under license from Dolby Laboratories Licensing Corporation.
- "Dolby" and "Double D" symbol are trademarks of Dolby Laboratories Licensing Corporation.
- C-Quam® is a registered trademark of Motorola.

Tips on Using Cassettes

- Do not touch the tape head with magnetic or hard objects. Head damage may occur resulting in undesirable sound reproduction.
- Do not use C-120 or longer cassettes. These tapes are thin and may stretch or break.
- Make sure there is no slack in the tape before inserting the cassette. Slack may be removed by rotating the hub with a pencil.
- Remove cassettes from the tape player when not in use. Store them in a cool, dry place. Exposure to direct sunlight, extreme temperatures, high humidity or magnetic fields may damage cassettes. Use of damaged cassettes may adversely affect performance of the tape player.

Cassette Tape And Player Maintenance

Maintain your cassette tape player. The head and capstan shaft in the cassette player can pick up dirt or tape deposits each time a cassette is played. The result of deposits on the capstan shaft may cause the tape to wrap around and become lodged in the tape transport. The other adverse condition is low or 'muddy' sound from one or both channels, as if the treble tone control were turned all the way down. To prevent this, you should periodically clean the head with a commercially available WET cleaning cassette.

As preventive maintenance, clean the head about every 30 hours of use. If you wait until the head becomes very dirty (noticeably poor sound), it may not be possible to remove all deposits with a simple WET cleaning cassette

CLIMATE CONTROLS

Heating

In snowy weather, always hood before driving your

For maximum heat, move and move temperature control lever temperature control lever comfort.

CLIMATE CONTROLS

Heating

In snowy weather, always clear the air inlet grille in the hood before driving your vehicle.

For maximum heat, move upper lever to HEAT position and move temperature control lever to WARM. Adjust temperature control lever and four-speed fan for your comfort.

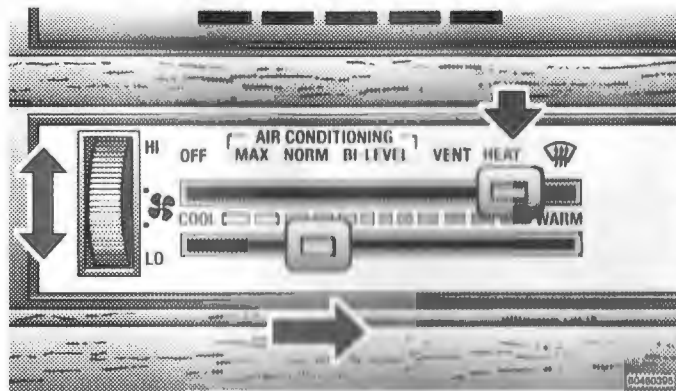

NOTE: The fan motor remains on unless upper control lever is OFF.

Defogging and Defrosting

For maximum defogging and defrost, push upper lever and temperature control lever all the way to the right. Position fan switch to "HI". Adjust temperature control and four-speed fan for comfort.

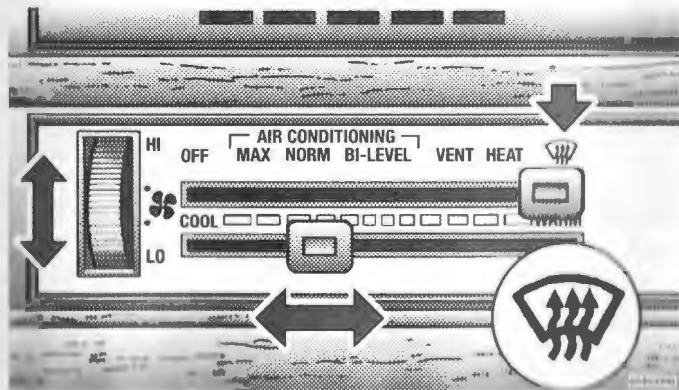

The BI-LEVEL setting directs air flow from instrument panel and floor outlets.

On air conditioned vehicles, the compressor will operate when in the defrost/defog mode and when the outside temperature is above 30°F (-1°C) to provide additional defogging. Defogging can also be obtained in the MAX, NORM and BI-LEVEL modes when the outside temperature is above 30°F.

NOTE: To improve fuel economy, leave in Defrost only when necessary.

WARNING

Sudden loss of visibility could lead to an accident. Vehicles or other obstacles on the windshield during frost or snow. Windshield with defroster. Windshield washer use.

Window Fogging

Vehicle windows tend to fog in cold weather or humid weather. Turn on the defroster in NORM mode and high blower. Turn the side windows down toward the side windows.

WARNING!

Sudden loss of visibility through the windshield could lead to an accident. You might not see other vehicles or other obstacles. To avoid sudden icing of the windshield during freezing weather, warm the windshield with defroster before and during windshield washer use.

Window Fogging

Vehicle windows tend to fog on the inside in mild rainy weather or humid weather. To clear the windows use the **WARM** mode and high blower. Direct the panel outlet toward the side windows.

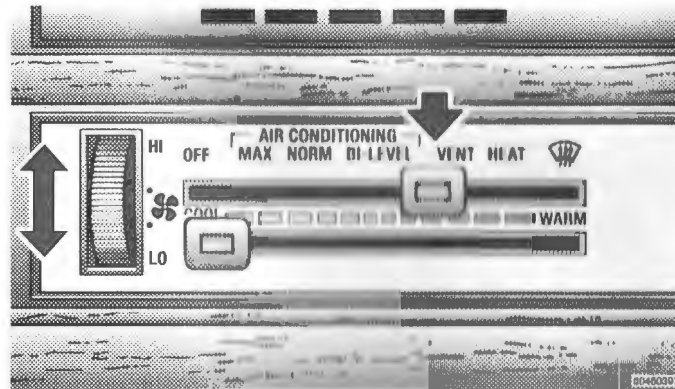
Fresh Air Ventilation

Set upper lever at **VENT**. Adjust temperature control lever and four-speed fan for your comfort.

Air Conditioning

For fast cool-down when first entering the vehicle, roll front windows down a little to expel hot air. Temporarily set upper lever at MAX, set temperature control lever at COOL position, and fan at HI.

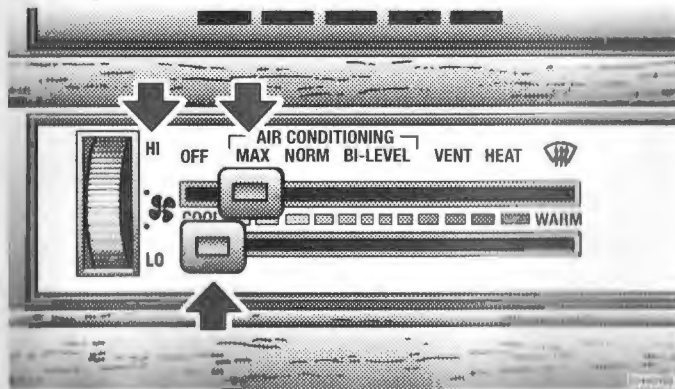

The MAX setting prevents dust and odors from entering the vehicle and it cools and removes moisture quickly from the interior by recirculating only the air already inside your vehicle.

For prolonged air conditioner operation, always use fresh outside air by setting the upper lever for NORM or BI-LEVEL and adjust the temperature control and fan for your comfort.

The BI-LEVEL setting directs air flow from instrument panel and floor outlets.

CONTENTS

- Ignition/Starter Switch
- Key Reminder
- Starting Procedure
- Normal Starting
- Engine Block Heater
- After Starting
- Parking Brake
- Transmissions
- Manual Transmission

STARTING AND OPERATING

CONTENTS

■ Ignition/Starter Switch	93	□ Automatic Transmission	100
□ Key Reminder	94	■ Four Wheel Drive Operation	103
■ Starting Procedure	94	□ Selec-Trac 4-Wheel Drive	103
□ Normal Starting	94	□ Command-Trac 4-Wheel Drive	106
□ Engine Block Heater	95	■ Trac-Lok Rear Axle	109
□ After Starting	96	■ Driving Tips	109
■ Parking Brake	96	□ On-Pavement Driving Tips	109
■ Transmissions	98	□ Off-Pavement Driving Tips (4WD Models)	109
□ Manual Transmission	98	■ Tires	113

92 STARTING AND OPERATING

- Tire Pressures 113
- Tire Replacement 115
- Treadwear Indicators 116
- Tire Rotation 117
- Alignment And Balance 117
- Tire Chains Or Traction Devices 118
- Anti-Lock Brake System 118
- Fuel Requirements 121
 - Gasoline/Oxygenate Blends 121
 - Reformulated Gasoline 122
 - Fuel System Cautions 123
 - Carbon Monoxide Warnings 124
- Fuel Tank Filler Cap (Gas Cap) And Fuel Filler Door 125
 - Fuel Tank Capacity 125
- Catalytic Converter 126
- Trailer Towing And Campers 127
 - Trailer Towing Warnings 128
 - Trailer And Tongue Weight 129
 - Trailer Towing — Hitches 130
 - Trailer Towing Requirements 130
 - Cooling System Tips — Trailer Towing 131
- Snow Plow 131
- Recreational Towing (Behind Motorhome, Etc.) 131
 - 4x4 Vehicles 131
 - 2 Wheel Drive Vehicles 131

IGNITION/STARTER SWITCH

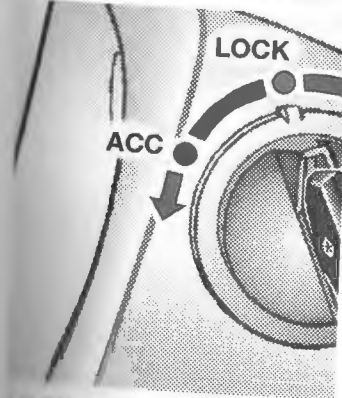

LOCK
Locks ignition switch and
automatic transmission shift

IGNITION/STARTER SWITCH

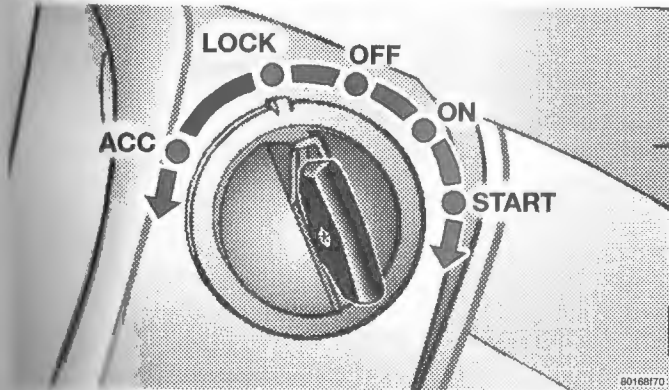
**LOCK**

Locks ignition switch and steering wheel. Also locks automatic transmission shift control in Park position

OFF

Unlocks steering wheel and automatic transmission shift control with engine off.

ON

This is normal running position.

START

Starts the engine. When engine starts, release the key. The ignition key will return to ON for normal driving.

ACCESSORY

Allows electrical accessories to be used when the engine is not running.

NOTE: The steering column may lock and prevent movement of the ignition key or steering wheel when trying to start the vehicle. Turn the steering wheel firmly in the direction the wheels are turned and rotate the ignition switch toward the OFF position.

WARNING!

- Never remove the ignition key or move switch to the LOCK position while the vehicle is moving. This could result in a locked steering wheel and loss of steering control. If you must turn the ignition off with the vehicle in motion, turn key to the OFF position only.
- Never reach through the steering wheel to operate controls, particularly while starting the vehicle. If front wheels were turned while vehicle was parked, the steering wheel may spring back and your hands or arms may be injured.

Key Reminder

An alarm will sound to remind you if the key is left in the ignition and the driver's door is opened.

STARTING PROCEDURE**Normal Starting**

Normal starting of either a cold or a warm engine is accomplished without pumping or depressing the accelerator pedal. Simply turn the key to the "START" position and release when the engine starts. If the engine fails to start within 10 seconds, turn the key to the "OFF" position, wait 5 seconds, then repeat the normal starting procedure. If the engine fails to start after you have followed the "Normal Starting" procedure, it may be flooded. Push the accelerator pedal all the way to the floor and hold it there while cranking the engine. This should clear any excess fuel in case the engine is flooded.

NOTE: To prevent damage to the starter, do not crank the engine for more than 15 seconds at a time. Wait 10 to 15 seconds before trying again.

If the engine has been flooded, it may start to run, but not have enough power to continue running when the key is

released. If this occurs, cover the accelerator pedal pushed all the way to the floor and the accelerator pedal and the key to the "OFF" position smoothly.

If the engine shows no signs of starting after two second periods of cranking with the accelerator pedal held to the floor, the "Normal Starting" procedure should be repeated.

CAUTION

Long periods of engine cranking will raise exhaust temperatures well above normal. Do not leave your vehicle with the engine running.

released. If this occurs, continue cranking with the accelerator pedal pushed all the way to the floor. Release the accelerator pedal and the key once the engine is running smoothly.

If the engine shows no sign of starting after two 15 second periods of cranking with the accelerator pedal held to the floor, the "Normal Starting" procedure should be repeated.

CAUTION!

Long periods of engine idling can cause excessive exhaust temperatures which can damage your vehicle. Do not leave your vehicle unattended with the engine running.

WARNING!

Do not leave children or animals inside parked vehicles in hot weather. Interior heat build up may cause serious injury or death.

Engine Block Heater

The engine block heater warms engine coolant and permits quicker starts in cold weather. Connect the cord to a standard 110-115 volt AC electrical outlet with grounded three wire extension cord.

The engine block heater cord is located under the hood near the air cleaner assembly.

WARNING!

Remember to disconnect the cord before driving. Damage to the 110-115 volt electrical cord could cause electrocution.

After Starting

The idle speed is automatically controlled on Multiport Fuel Injected engines and will decrease as the engine warms up.

PARKING BRAKE

To set brake, pull the lever up as firmly as possible.

NOTE: The instrument cluster brake warning light indicates only that the parking brake is applied. You must be sure the parking brake is fully applied before leaving the vehicle.

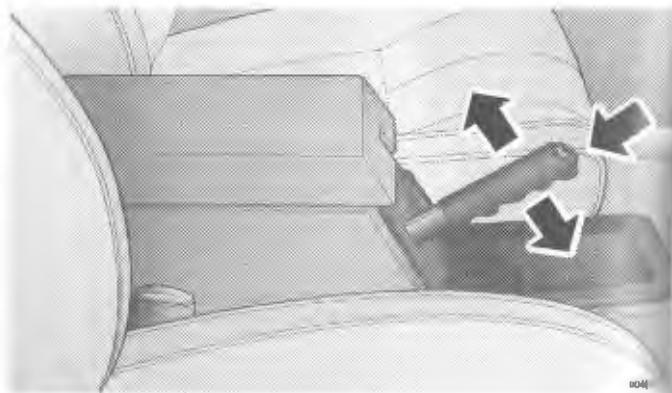

To release, pull up slightly, press center button, then lower lever completely.

If the parking brake is not completely released, the instrument cluster warning light will remain on.

NOTE: Your vehicle has a parking brake and we do not recommend that the maintenance performed when parking on a hill, it is to set the parking brake before placing gear selector on the transmission lock. If it is difficult to move the selector, consult your manual. On an uphill grade and away from traffic.

NOTE: Your vehicle has automatically adjusting rear brakes and we do not recommend any adjustment other than the maintenance performed by your Jeep dealer.

When parking on a hill, it is important to set the parking brake before placing gear selector in Park, otherwise the load on the transmission locking mechanism may make it difficult to move the selector out of Park. As an added precaution, turn the front wheels toward the curb on a downhill grade and away from the curb on an uphill grade.

WARNING!

- Always fully apply the parking brake when leaving your vehicle, or vehicle may roll and cause damage or injury. Also be certain to leave an automatic transmission in P (Park), a manual transmission in 1st gear. Failure to do so may cause the vehicle to roll and cause damage or injury.
- Leaving children in a vehicle unattended is dangerous for a number of reasons. A child or others could be injured. Children should be warned not to touch the parking brake release lever or the gear selector lever. Don't leave the keys in the ignition. A child could operate power windows, other controls, or move the vehicle.
- Be sure the parking brake is fully disengaged before driving, failure to do so can lead to brake failure and an accident.

Transmissions

Manual Transmission

Follow the shift pattern for your transmission.

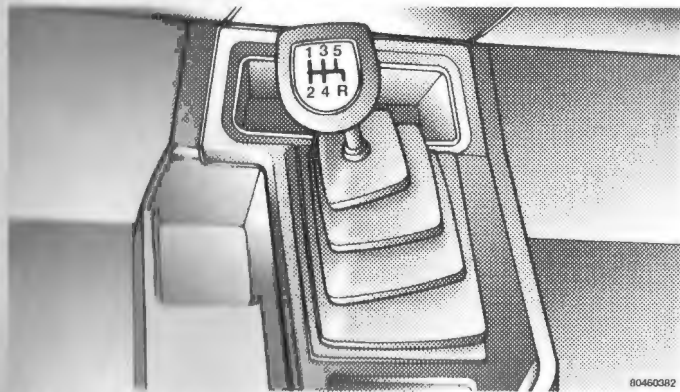

80460382

NOTE: The backup lights will come on when your vehicle is in reverse gear and the ignition is in the ON position.

WARNING!

When parking your vehicle, always leave a manual transmission in gear and apply the parking brake fully to guard against vehicle movement and possible injury or damage. Never use any gear as a substitute for the parking brake.

WARNING!

Do not coast in Neutral and never turn off the ignition to coast down a hill. These are unsafe practices that limit your response to changing traffic or road conditions. You might lose control of the vehicle.

CAUTION

To drive as safely as possible, always use the correct shift pattern of your manual transmission.

- Before shifting from a forward gear to reverse, stop the vehicle completely. Other shifting may result.
- Do not operate at sustained speeds in lower gears. Engine damage may result.
- Shift smoothly to avoid gear grinding. Do not shift into a low gear while the vehicle is in a high gear. Engine or clutch damage may result.
- Do not rest your foot on the clutch pedal while driving. This causes heel damage to the clutch.

CAUTION!

To drive as safely as possible and to prolong the life of your manual transmission follow these tips:

- Before shifting from a forward gear into reverse, or from reverse to a forward gear, be certain to stop vehicle completely. Otherwise, transmission damage may result.
- Do not operate at sustained high engine or road speeds in lower gears. Engine damage may result.
- Shift smoothly to avoid grinding gears. Do not downshift into a low gear while traveling at too high a speed for that gear. Engine or transmission damage may result.
- Do not rest your foot on the clutch pedal while driving or idling. This causes heat buildup and damages the clutch.

- When you slow down or go up a grade, do not overload or “lug” the engine by driving too slowly for a gear. Downshift as speed requires or the engine may overheat.
- Never hold the vehicle stopped on a hill by using the clutch pedal. The clutch may be damaged.
- Push in the clutch pedal completely when shifting. Otherwise, transmission or clutch damage may result.
- When “rocking” a stuck vehicle by shifting between a forward gear and reverse, do not spin wheels faster than 15 mph (24 km/h), or drivetrain damage may result.

Recommended Manual Transmission Shifting Speeds

On vehicles with a manual transmission, a Shift Indicator Light in the instrument cluster reminds you when to shift to the next higher gear.

Automatic Transmission

Brake Park Interlock System

This system prevents you from moving the gear shift out of park and into any gear unless the brake pedal is pressed. This system is active only while the vehicle is running.

4.0L Engine

Shifting from Drive to Park or Reverse (or from Park or Reverse to Drive) should be done only after the accelerator pedal is released and the vehicle is stopped. Be sure to keep your foot on the brake when moving the shift lever between these gears.

Park, Reverse and Drive 1-2 can be selected after the shift lever is unlocked by pressing the button (A) on the left side of shift handle.

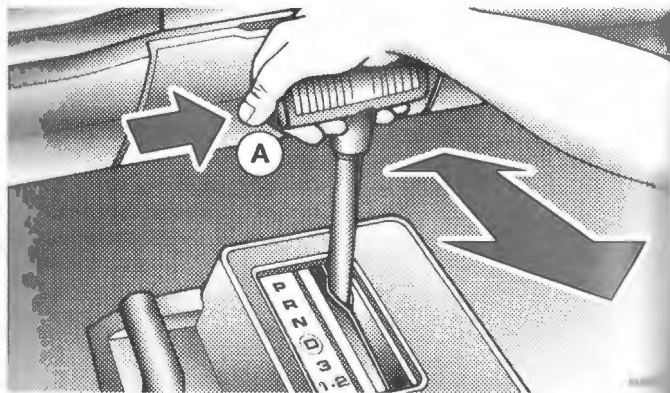

P (Park)

Locks the transmission when the key is removed from the ignition lock. Do not place gearshift in the Park position unless the vehicle is totally stopped. The Park position is used when starting the vehicle.

WAR

Your vehicle could move if it is not completely in Park. Do not move the gearshift lever out of Park without depressing the shift button. Make sure it is in Park before

R (Reverse)
For moving the vehicle rearward, move the lever to R, except when the engine may be started in this

N (Neutral)

Engine may be started in this

WARNING!

Your vehicle could move and injure you or others if it is not completely in P (Park). Check by trying to move the gearshift lever back and forth without depressing the shift button after you have set it in P. Make sure it is in Park before leaving the vehicle.

R (Reverse)

For moving the vehicle rearward. Always stop before moving the lever to R, except when rocking the vehicle.

N (Neutral)

Engine may be started in this position.

WARNING!

Do not coast in Neutral and never turn off the ignition to coast down a hill. These are unsafe practices that limit your response to changing traffic or road conditions. You might lose control of the vehicle.

D (Drive)

For all normal driving. Begins at a stop in 1st gear with automatic upshifts to 2nd, 3rd and 4th. Downshifts automatically as needed.

3 (Drive 3)

For driving in hilly areas, towing a trailer, or whenever frequent transmission shifting occurs, and to assist braking on dry pavement or in mud and snow. Begins at a stop in 1st gear with automatic upshift to 2nd and 3rd gear. Will not shift to 4th.

1-2 (Drive 1-2)

For hard pulling at low speeds in mud, sand, snow, or on steep grades. When towing a trailer up steep grades, shift to this position to avoid possible transmission overheating. The range begins in 1st gear with automatic upshift to 2nd, and provides engine compression braking at low speeds.

Torque Converter Clutch

A feature designed to improve fuel economy has been added to the automatic transmission of this vehicle. A clutch within the torque converter engages automatically at calibrated speeds. This may result in a slightly different feeling or response during normal operation in high gear. When the vehicle speed drops, or during deceleration, the clutch automatically and smoothly disengages.

WARNING!

Never use Park position on an automatic transmission as a substitute for the parking brake. Always apply parking brake fully when parked to guard against vehicle movement and possible injury or damage.

CAUTION!

To drive as safely as possible and to prolong the life of your automatic transmission, follow these tips:

- Before moving the shift lever out of Park, you must turn the ignition from LOCK to ON so steering wheel and shift lever are released. Otherwise, damage to steering column or shifter could result.

- Never race the engine of a vehicle in gear, and never race a vehicle up an incline without applying the parking brake. This can cause overheating and damage to the transmission.

- When "rocking" a stuck vehicle, use Drive (D) and Reverse (R) alternately. Do not exceed 15 mph (24 km/h) to avoid damage to the transmission.

FOUR WHEEL DRIVE OPERATION**4-Drive (4-Drive) Operation**

4-Drive provides:

- 2 wheel drive in 2WD (Full Range).
- Part-time 4-wheel drive in 4WD (Full Range).

- Never race the engine with the brakes on and the vehicle in gear, and never hold the vehicle on an incline without applying the brakes. These practices can cause overheating and damage to the transmission.
- When “rocking” a stuck vehicle by moving between D (Drive) and R (Reverse), do not spin the wheels faster than 15 mph (24 km/h), or drivetrain damage may result.

FOUR WHEEL DRIVE OPERATION

How Trac 4-Wheel Drive

How Trac provides:

- 2-wheel drive in 2WD (High range).
- Part-time 4-wheel drive in 4x4 PART TIME (High range)

- Full-time 4-wheel drive in 4x4 FULL TIME (High Range).

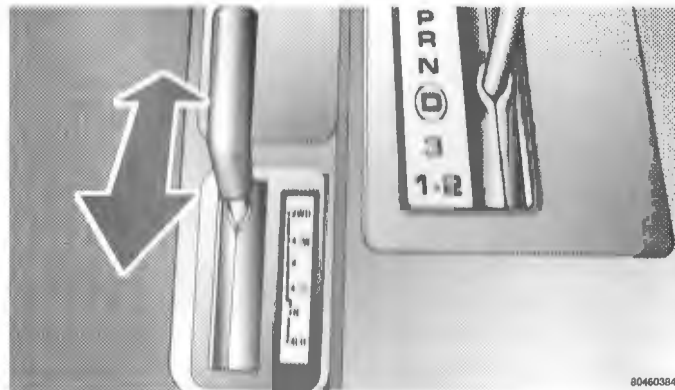

- Neutral position (N) to disengage axles from the powertrain. Refer to the Towing A Disabled Vehicle Section for towing instructions.
- Part-time 4-wheel drive in 4 LO (Low range).

- Indicator lights in the instrument cluster showing in which 4-wheel drive mode the vehicle is operating. The green FULL TIME lamp indicates full-time 4-wheel drive (4x4 FULL TIME). The amber PART TIME lamp indicates part-time 4-wheel drive (4x4 PART TIME or 4 LO).

WARNING!

Do not leave vehicle unattended with the transfer case in the Neutral (N) position without first fully engaging the parking brake. The transfer case Neutral (N) position disengages both axles and will allow the vehicle to move regardless of the transmission position.

Transfer Case Shifting

- **2WD Position**

This position is for driving on hard-surfaced roads under normal driving conditions when 4-wheel drive is not desired.

- **4x4 PART TIME Position**

This position is designed for temporary use of 4-wheel drive when on- or off-road conditions such as deep snow or heavy ice require increased traction. When engaged both the front and rear axles are mechanically locked together and turn at the same speed. **Do not use 4x4 PART TIME on dry, paved roads.**

To engage, shift transfer case lever from 2WD to 4x4 PART TIME while the vehicle is moving at any legal speed.

- **4x4 FULL TIME Position**

This is the primary 4-wheel drive position. It provides better traction when roads are slippery. When engaged, the front and rear axles turn at different speeds to ease steering. Select 4x4 FULL TIME when you need extra traction if you wish.

To engage, shift transfer case lever to 4x4 FULL TIME while the vehicle is moving.

- **4 LO Position**

This position is designed for use when off-road conditions require maximum pulling power. **Do not use 4 LO on dry, paved roads.** To engage, slow the vehicle to a stop, shift the transmission into Neutral, and move the transfer case lever to the right and p

4x4 FULL TIME Position

This is the primary 4-wheel drive position which offers better traction when roads are wet, snow covered or icy. When engaged, the front and rear axles are permitted to turn at different speeds to enhance maneuverability. Use Trac 4x4 FULL TIME year round on all road surfaces if you wish.

To engage, shift transfer case from 2WD to 4x4 FULL TIME while the vehicle is moving at any legal speed.

4 LO Position

This position is designed for temporary use of 4-wheel drive when off-road conditions require added low speed pulling power. **Do not use 4 LO on dry, paved roads.**

To engage, slow the vehicle to 2-3 mph (3-5 km/h), shift the transmission into Neutral (N), then shift the transfer case lever to the right and pull firmly rearward to 4 LO.

CAUTION!

Never attempt to engage Low Range when the vehicle is moving faster than 2-3 mph (3-5 km/h). Transfer case damage may result.

When shifting from 2WD through 4x4 PART TIME to 4x4 FULL TIME, two momentary releases of the accelerator pedal may be required.

NOTE: Delayed shifts into or out of 4-wheel drive may be experienced due to uneven tire wear, low tire pressure, excessive vehicle loading, or cold temperatures.

WARNING!

Failure to engage a position completely can cause transfer case damage or loss of power and vehicle control. You could have an injury accident. Do not drive the vehicle unless the transfer case is fully engaged.

Command-Trac 4-Wheel Drive

Command-Trac provides a part-time 4-wheel drive. When engaged, both the front and rear axles are mechanically locked together and turn at the same speed.

The Command-Trac system consists of:

- 2-wheel drive in 2H (High Range).
- Part-time 4-wheel drive in 4H (High Range)
- Neutral (N) position to disengage axles from powertrain. See **What To Do In Emergencies** Section for towing instructions.

- Part-time 4-wheel drive in 4L (Low Range).
- An amber PART TIME indicator light in the instrument cluster showing that the vehicle is operating in 4-wheel drive (4H or 4L).

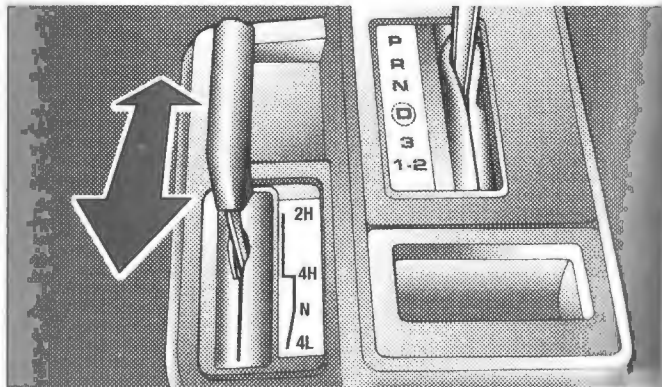
**WARN**

Do not leave vehicle unattended in the Neutral (N) position with the parking brake disengaged. Allow the vehicle to move to a safe position.

WARNING!

Do not leave vehicle unattended with the transfer case in the Neutral (N) position without first fully engaging the parking brake. The transfer case Neutral (N) position disengages both axles and will allow the vehicle to move regardless of the transmission position.

CAUTION!

Never operate a Command-Trac vehicle in 4-wheel drive on dry, hard-surfaced roads for a sustained period, and use 4L only when needed for added pulling power. Using 4-wheel drive on such roads will cause stress and possible damage to components, as well as make shifting difficult. To reduce shifting effort, drive the vehicle in reverse for a few feet, or drive off the hard-surfaced road momentarily to allow tire slippage.

Transfer Case Shifting

2H Position

This position is designed for driving on hard-surfaced roads under normal driving conditions when 4-wheel drive is not needed.

4H Position

This position is designed for **temporary** use of 4-wheel drive for traction when driving in rain, snow, mud, sand or when driving off-road. **Do not use 4H on dry, paved roads.**

To engage, shift the transfer case lever from 2H to 4H while the vehicle is moving at any legal speed.

4L Position

This position is designed for **temporary** use of 4-wheel drive when off-road driving conditions require added low speed pulling power. **Do not use 4L on dry paved roads.**

To engage, slow the vehicle to 2-3 mph (3-5 km/h), shift the transmission to Neutral (N), then shift the transfer case lever to the right and pull firmly rearward to 4L.

WARNING!

Failure to engage a position completely can cause transfer case damage or loss of power and vehicle control. You could have an injury accident. Do not drive the vehicle unless the transfer case is fully engaged.

CAUTION!

Never attempt to engage Low range when vehicle is moving faster than 2-3 mph (3-5 km/h). Transfer case damage may result.

TRAC-LOK REAR AXLE

The optional Trac-Lok rear axle provides driving force to both rear wheels. It is used by the loss of traction. When traction differs between the front and rear, Trac-Lok automatically provides more torque to the rear wheels.

Trac-Lok is especially helpful in slippery conditions. With both rear wheels, a slight application of the accelerator provides maximum traction. When starting on an excessively slippery surface, a slight application of the parking brake provides maximum traction.

DRIVING TIPS

On Pavement Driving Tips
Utility vehicles have higher ground clearance than most passenger vehicles, but a narrower track than most passenger vehicles.

TRAC-LOK REAR AXLE

The optional Trac-Lok rear axle provides a constant driving force to both rear wheels and reduces wheel spin caused by the loss of traction at one driving wheel. If traction differs between the two rear wheels, the differential automatically proportions the usable torque by providing more torque to the wheel that has traction.

Trac-Lok is especially helpful during slippery driving conditions. With both rear wheels on a slippery surface, a slight application of the accelerator will supply maximum traction. When starting with only one rear wheel on an excessively slippery surface, slight momentary application of the parking brake may be necessary to gain maximum traction.

DRIVING TIPS

Off-Pavement Driving Tips

Utility vehicles have higher ground clearance and a narrower track than most passenger cars to make them

capable of performing in a wide variety of off-road applications. Specific design characteristics give them a higher center of gravity than ordinary cars. An advantage of the higher ground clearance is a better view of the road, allowing you to anticipate problems. They are not designed for cornering at the same speeds as conventional 2-wheel drive vehicles any more than low slung sports cars are designed to perform satisfactorily under off-road conditions. If at all possible, avoid sharp turns or abrupt maneuvers. As with other vehicles of this type, failure to operate this vehicle correctly may result in loss of control or vehicle rollover.

Off-Pavement Driving Tips (4WD Models)

There are a number of differences between driving on pavement and driving off-pavement. While off-pavement operation lets you get into country where roads won't take you, it also has some hazards you won't meet on the highway. So please read this section carefully before going off-pavement in your Jeep vehicle. It will

help you get the most from what your vehicle offers. And it will give you some tips on having a safe off-pavement experience.

When To Use Low Range

When off-pavement, shift to Low range for additional traction in pulling forward or descending a hill, for low-speed pulling power or to improve handling and control on slippery or difficult terrain. Also use Low on the road in rain, ice, snow, mud or sand to get heavy loads rolling, or whenever High range four-wheel drive traction will not do the job.

In Snow, Mud And Sand

In heavy snow, when pulling a load, or for additional control at slower speeds, shift the transmission to a low gear and shift the transfer case to Low if necessary. Don't shift to a lower gear than necessary to maintain headway. Over-revving the engine can spin the wheels and traction will be lost.

Do not downshift on icy or slippery roads, because engine braking may cause skidding and loss of control.

When driving on soft sand deflate your tires to allow greater surface area. You must return the tires to normal air pressure before driving on pavement or other hard surfaces.

Hill Climbing

Before climbing a steep hill, change transmission to a lower gear and shift the transfer case to Low. Use first gear and Low for very steep hills.

If you stall or begin to lose headway while climbing a steep hill, allow your vehicle to come to a stop and immediately apply the brakes. Start the engine and shift to reverse. Back slowly down the hill allowing the compression braking of the engine and transmission to help regulate your speed. If the brakes are required to control vehicle speed, apply them lightly and avoid locking or skidding the tires.

WARN

If the engine stalls or you
make it to the top of a s
attempt to turn around.
tipping and rolling the v
tully straight down a hill i
down a hill in N (Neutral
depressed, using only the
Remember, never drive d
always drive straight up o

If the wheels start to slip as
hill, ease off the accelerator
during the front wheels shar
provide fresh "bite" into th
provide traction to complete

WARNING!

If the engine stalls or you lose headway or cannot make it to the top of a steep hill or grade, never attempt to turn around. To do so may result in tipping and rolling the vehicle. Always back carefully straight down a hill in reverse gear. Never back down a hill in N (Neutral) or with the clutch pedal depressed, using only the brake.

Remember, never drive diagonally across a hill — always drive straight up or down.

If the wheels start to slip as you approach the crest of a hill, ease off the accelerator and maintain headway by steering the front wheels sharply left and right. This will provide fresh "bite" into the surface and will usually provide traction to complete the climb.

Traction Downhill

Shift the transmission into a low gear and transfer case to Low range. Let the vehicle go slowly down the hill with all four wheels turning against engine compression drag. This will permit you to control the vehicle speed and direction.

When descending mountains or hills, repeated braking can cause brake fade with loss of braking control. Avoid repeated heavy braking by downshifting the transmission whenever possible.

After Driving Off-Pavement

Off-pavement operation puts more stress on your vehicle than does most on highway driving. After going off-pavement it is always a good idea to check for damage. That way you can get any problems taken care of right away and have your Jeep ready when you need it.

- Completely inspect the underbody of your vehicle. Check tires, body structure, steering, suspension, and exhaust system for damage.
- Check threaded fasteners for looseness, particularly on the chassis, drivetrain components, steering, and suspension. Retighten them, if required, and torque to the values specified in the Service Manual.
- Check for accumulations of plants or brush. These things could be a fire hazard. Or they might hide damage to fuel lines, brake hoses, axle pinion seals, and propeller shafts.
- After extended operation in mud, sand, water, or similar dirty conditions, have brake drums, brake linings, and axle yokes inspected and cleaned as soon as possible.

WARNING!

Abrasive material in any part of the brakes may cause excessive wear or unpredictable braking. You might not have full braking power when you need it to prevent an accident. If you have been operating your vehicle in dirty conditions, get your brakes checked and cleaned as necessary.

- If you experience unusual vibration after driving in mud, slush or similar conditions, check the wheels for impacted material. Impacted foreign material can cause a wheel imbalance and freeing the wheels will correct the situation.

TIRES

Tire Pressures

The tire pressures should be checked regularly. On hot days the pressures will be higher after high speed driving.

IMPORTANT: Check tire condition at least once a month and before any long trip. Use the maximum cold tire inflation pressure for the tire sidewall.

Cold Tire Pressures

Tire Size	Pressure (psi)
P185/75R15	35
P195/75R15	35
P195/70R15	35
Compact Spare Tire	60

These pressures assume the vehicle is loaded with 5 passengers and 400 lbs of cargo.

TIRES

Tire Pressures

The tire pressures should be checked when tires are cold. On hot days the pressures will be 4 to 8 psi (28 to 56 kPa) higher after high speed driving.

IMPORTANT: Check tire condition and pressure at least once a month and before any long trip. Never exceed the maximum cold tire inflation pressure shown on the tire sidewall.

Cold Tire Pressures

Tire Size	Full Load Pressures*
P185/70R15	33 psi (228 kPa)*
P195/70R15	33 psi (228 kPa)*
P205/70R15	33 psi (228 kPa)*
Compact Spare Tire	60 psi (414 kPa)±

*These pressures assume the vehicle is carrying no more than 3 passengers and 400 lbs. (181 kg) cargo.

*For sustained speeds in excess of 65 mph (104 km/h), increase inflation pressure 3 psi (21 kPa). Pressure should not exceed 35 psi (241 kPa).

WARNING!

The wrong tires or improper tire maintenance can lead to an accident. Follow these directions to tire safety:

- Your vehicle must be equipped with the same size and type tires of equal circumference on all four wheels, except when temporarily using the limited mileage spare tire. Do not mix radial-ply and bias-ply or bias-belted tires. If all tires are not of the same size and type, unpredictable handling may result.
- Sustained high speeds of more than 75 mph (121 km/h) for one hour or more are not recommended for mud and snow tires, and may lead to tire failure.

- Certain combinations of special aftermarket tires and wheels may change tread measurement, resulting in difficult transfer case shifting, changes of steering and suspension geometry. This can cause unpredictable handling and stress to steering and suspension components. Therefore, use only tire and wheel sizes and types approved for your vehicle.
- Low pressures cause premature wear and heat buildup, which could result in adverse vehicle handling or possible blowout, as well as poor traction on wet roads (especially with worn tires). Do not decrease inflation pressure if tires are hot. If tire pressure must be adjusted while tires are hot, temporarily set pressure at 6 psi (42 kPa) greater than pressure specified (10 psi [70 kPa] greater for sustained high speed driving). When adjusting inflation pressure on cold tires, do not exceed specified maximum pressure.
- Driving accidents, such as hitting curbs, can damage tires and also disrupt wheel alignment, so check tire and alignment periodically.
- Uneven tire wear, unapproved tire and wheel sizes and types, and low pressures may cause difficult transfer case shifting. Use only approved tire and wheel sizes and types approved for your vehicle. Rotating approved tires should be attempted before replacing tires when trying to improve transfer case shifting.
- Overloading your tires is dangerous. Like underinflation, overloading can cause tire failure. The result could be an accident. Use tires with the recommended load capacity for your vehicle, and never overload them.

Tire Replacement

The tires on your new vehicle have specific characteristics. They should be used with proper wear and correct inflation pressure. The manufacturer recommends that you use tires with the same quality and performance as the tires on your vehicle. The section on tread wear and equivalent replacement tires in the Owner's Manual explains handling and ride of your vehicle. If you have any questions you may have, contact your original equipment dealer.

Tire Replacement

The tires on your new vehicle provide a balance of many characteristics. They should be inspected regularly for wear and correct inflation pressure. Chrysler strongly recommends that you use tires equivalent to the originals (see section on tread wear indicators). Failure to use equivalent replacement tires may adversely affect the handling and ride of your vehicle. We recommend that you contact your original equipment tire dealer on any questions you may have on tire specifications or capability.

WARNING!

- Never use a tire smaller than the minimum tire size listed on your vehicle's tire placard. Using a smaller tire could result in tire overloading and failure.
- Failure to equip your vehicle with tires having adequate speed capability can result in sudden tire failure and loss of vehicle control.
- Overloading your tires is dangerous. Like under-inflation, overloading can cause tire failure. Use tires of the recommended load capacity for your vehicle - never overload them.

CAUTION!

Replacing original tires with tires of a different size may result in false speedometer and odometer readings. Check with your dealer before replacing tires with a different size.

CAUTION!

When using a Compact Spare Tire, disengage 4-wheel drive or damage to the transfer case could result.

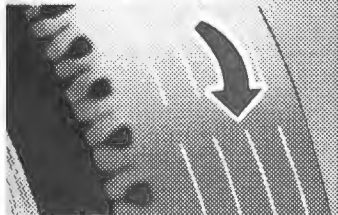
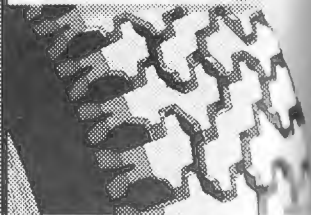
Treadwear Indicators**WORN TIRE****TIRE WEAR INDICATOR****NEW TIRE**

These indicators are narrow strips 1/16 inch (1.6 mm) thick and are found in the tread pattern grooves.

When the tread pattern is worn down to these treadwear indicators, the tires should be replaced.

Overloading your vehicle, loading and driving on bad roads r

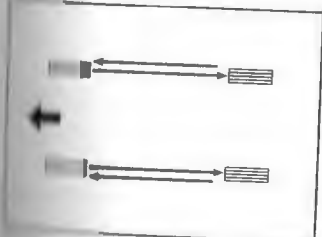
Tire Rotation

8008a59d

... for any rapid or un
... before you rotate the

Alignment and Balance

... obtain full tire tread mil
... components of your vehicle i

... ty.

Overloading your vehicle, long trips in very hot weather, and driving on bad roads may result in greater wear.

Tire Rotation

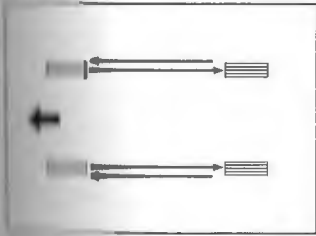

Rotation is recommended at 7,500 miles (12 000 km) if you are following Maintenance Schedule "A" and at 6,000 miles (9 600 km) intervals if you are following Maintenance Schedule "B".

More frequent rotation is permissible if desired. The

reasons for any rapid or unusual wear should be corrected before you rotate the tires.

Alignment and Balance

To obtain full tire tread mileage, have the suspension components of your vehicle inspected and aligned when necessary.

Poor suspension alignment may result in:

- fast tire wear;
- uneven tire wear, such as feathering and one-sided wear;
- vehicle pull to the right or to the left.

Tires may also cause your vehicle to pull to the left or right. But alignment won't correct this condition. See your dealer for proper diagnosis of the problem.

If your vehicle vibrates, you may have a tire and wheel out of balance. Proper balancing will reduce vibration and avoid tire cupping and spotty wear. Improper alignment will not cause vehicle vibration.

Tire Chains Or Traction Devices

Most Cherokee models have sufficient tire-to-body clearance to allow use of tire chains. Install chains on rear tires only. Follow these recommendations to guard against damage and excessive tire and chain wear:

- Do not install tire chains or traction devices on models with P225/75 R15 or larger size tires. These tires are too large for sufficient body clearance with chains or other traction devices.
- Use SAE class "S" tire chains or traction devices only.
- Follow the chain manufacturer's instructions for mounting chains.
- Install chains snugly and tighten after mile (1 km) of driving.
- Do not exceed 45 mph (72 km/h), or lower speeds if manufacturer advises.

- Drive cautiously, avoiding large bumps, potholes and extreme driving maneuvers.
- Do not use chains or traction devices on the Compact Spare tire.

ANTI-LOCK BRAKE SYSTEM

The Anti-Lock Brake System is designed to aid the driver in maintaining vehicle control under adverse braking conditions. The system operates with a separate computer to modulate hydraulic pressure to prevent wheel lock-up and help avoid skidding on slippery surfaces.

All vehicle wheels and tires must be the same size and type and tires must be properly inflated to produce accurate signals for the computer.

WAR

Significant over- or under-
ing sizes of tires or wheel
loss of braking effectiveness

The Anti-Lock Brake System
will test at about 6 mph. If y
the brake while this test is o
pedal movement. This is nor

The Anti-Lock system pump
will test at 6 mph and during
modulated hydraulic pressure
the humming noise during o

during off-road use, loss of
about the system and cause t
ate. Turn the ignition OFF
Anti-Lock Brake System func

WARNING!

Significant over- or under-inflation of tires, or mixing sizes of tires or wheels on the vehicle can lead to loss of braking effectiveness.

The Anti-Lock Brake System conducts a low speed self test at about 6 mph. If you have your foot lightly on the brake while this test is occurring you may feel slight pedal movement. This is normal.

The Anti-Lock system pump motor runs during the self test at 6 mph and during an ABS stop to provide the regulated hydraulic pressure. The motor pump makes a low humming noise during operation, this is normal.

During off-road use, loss of traction can temporarily disable the system and cause the warning light to illuminate. Turn the ignition OFF and ON again to restore Anti-Lock Brake System function.

WARNING!

Pumping of the Anti-Lock Brakes will diminish their effectiveness and may lead to an accident. Pumping makes the stopping distance longer. Just press firmly on your brake pedal when you need to slow down or stop.

CAUTION!

The Anti-Lock Brake System is subject to possible detrimental effects of electronic interference caused by improperly installed aftermarket radios or telephones.

NOTE: During severe braking conditions, a pulsing sensation may occur and a clicking noise will be heard. This is normal, indicating that the Anti-Lock Brake System is functioning.

WARNING!

To use your brakes and accelerate more safely, follow these tips:

- Do not "ride" the brakes by resting your foot on the pedal. This could overheat the brakes and result in unpredictable braking action, longer stopping distances, or brake damage.
- When descending mountains or hills, repeated braking can cause brake fade with loss of braking control. Avoid repeated heavy braking by downshifting the transmission whenever possible.

- Engines may idle at higher speeds during warm-up, which could cause rear wheels to spin and result in loss of vehicle control. Be especially careful while driving on slippery roads, in close-quarter maneuvering, parking or stopping. Remember, always engage 4-wheel drive when driving on slippery roads.
- Do not drive too fast for road conditions, especially when roads are wet or slushy. A wedge of water can build up between the tire tread and the road. This hydroplaning action can cause loss of traction, braking ability, and control. Under such conditions, engage 4-wheel drive.
- After going through deep water or a car wash, brakes may become wet, resulting in poor performance and unpredictable braking action. Dry the brakes by gentle, intermittent pedal action while driving at very slow speeds.

FUEL REQUIREMENTS

Your vehicle was designed to operate on unleaded gasoline and provide excellent performance. Use only high quality unleaded gasoline.

Use only unleaded gasoline with a minimum octane rating of 87.



If your vehicle develops a knocking sound (ping) at low engine speeds that continues to become a continued heavy knock at high speeds, it should be reported to your dealer.

NOTE: Engine damage due to prolonged operation may not be covered by warranty.

FUEL REQUIREMENTS

Your vehicle was designed to meet all emission regulations and provide excellent fuel economy when using high quality unleaded gasoline.



Use only unleaded gasoline having a minimum posted octane of 87.

If your vehicle develops occasional light spark knock (ping) at low engine speeds this is not harmful. However, continued heavy knock at high speeds can cause damage and should be reported to your dealer immediately.

NOTE: Engine damage as a result of heavy knock operation may not be covered by the new vehicle warranty.

In addition to using unleaded gasoline with the proper octane rating, those that contain detergents, corrosion and stability additives are recommended. Using gasolines that have these additives will help improve fuel economy, reduce emissions and maintain vehicle performance.

Poor quality gasoline can cause problems such as hard starting, stalling and stumble. If you experience these problems, use another brand of gasoline before considering service for the vehicle.

Gasoline/Oxygenate Blends

Some fuel suppliers blend unleaded gasoline with materials that contain oxygen such as alcohol, MTBE and ETBE. Oxygenates are required in some areas of the country in the winter months to reduce carbon monoxide emissions. The type and amount of oxygenate used in the blend is important.

The following are generally used in gasoline blends:

MTBE/ETBE

Gasoline and MTBE (Methyl Tertiary Butyl Ether) blends are a mixture of unleaded gasoline and up to 15% MTBE. Gasoline and ETBE (Ethyl Tertiary Butyl Ether) are blends of gasoline and up to 17% ETBE. Gasoline blended with MTBE or ETBE may be used in your vehicle.

Ethanol (Ethyl or Grain Alcohol)

Ethanol, properly blended, is used as a mixture of 10% ethanol and 90% unleaded gasoline. Gasoline blended with ethanol may be used in your vehicle.

Methanol (Methyl or Wood Alcohol)

Methanol is used in a variety of concentrations when blended with unleaded gasoline. You may find fuels containing 3% or more methanol along with other alcohols called cosolvents.

DO NOT USE GASOLINES CONTAINING METHANOL.

Use of methanol/gasoline blends may result in starting and driveability problems and damage critical fuel system components.

Problems that are the result of using methanol/gasoline blends are not the responsibility of Chrysler and may not be covered by the warranty.

Reformulated Gasoline

Many areas of the country are requiring the use of cleaner-burning fuel referred to as **Reformulated Gasoline**. Reformulated gasolines are specially blended to reduce vehicle emissions and improve air quality.

Chrysler Corporation strongly supports the use of reformulated gasolines wherever available. Although your vehicle was designed to provide optimum performance and lowest emissions operating on high quality unleaded

gasoline, it will perform equally well on reformulated gasoline. Lower emissions when operating on reformulated gasoline.

Fuel System Cautions

CAUTION

Follow these guidelines to maintain engine performance:

The use of leaded gasoline is not recommended. Using leaded gasoline can damage the emission control system and result in loss of warranty coverage.

An out-of-tune engine, or engine malfunctions, can cause engine overheating. If you notice a heavy amount of white smoke, your engine

gasoline, it will perform equally well and produce even lower emissions when operating on reformulated gasoline.

Fuel System Cautions

CAUTION!

Follow these guidelines to maintain your vehicle's performance:

- The use of leaded gas is prohibited by Federal law. Using leaded gasoline can impair engine performance, damage the emission control system, and could result in loss of warranty coverage.
- An out-of-tune engine, or certain fuel or ignition malfunctions, can cause the catalytic converter to overheat. If you notice a pungent burning odor or some light smoke, your engine may be out of tune or

malfunctioning and may require immediate service. Contact your dealer for service assistance.

- When pulling a heavy load or driving a fully loaded vehicle when the humidity is low and the temperature is high, use a premium unleaded fuel to help prevent spark knock. If spark knock persists, lighten the load, or engine piston damage may result.
- The use of fuel additives which are now being sold as octane enhancers is not recommended. Most of these products contain high concentrations of methanol. Fuel system damage or vehicle performance problems resulting from the use of such fuels or additives is not the responsibility of Chrysler Corporation and may not be covered under the New Vehicle Warranty.

NOTE: Intentional tampering with emissions control systems can result in civil penalties being assessed against you.

Carbon Monoxide Warnings

WARNING!

Carbon monoxide (CO) in exhaust gases is deadly. Follow the precautions below to prevent carbon monoxide poisoning:

- Do not inhale exhaust gases. They contain carbon monoxide, a colorless and odorless gas which can kill. Never run the engine in a closed area, such as a garage, and never sit in a parked vehicle with the engine running for an extended period. If the vehicle is stopped in an open area with the engine running for more than a short period, adjust the ventilation system to force fresh, outside air into the vehicle.
- Guard against carbon monoxide with proper maintenance. Have the exhaust system inspected every time the vehicle is raised. Have any abnormal conditions repaired promptly. Until repaired, drive with all side windows fully open.
- Always open the fresh air vents when driving with any windows open, even if only slightly, to help keep fresh air circulating inside vehicle. Otherwise, poisonous exhaust gases could be drawn into the vehicle.
- Keep the liftgate closed when driving your vehicle to prevent carbon monoxide and other poisonous exhaust gases from entering the vehicle.

**FUEL TANK FILLER CAP (C
FILLER DOOR**
To open, press on the left (lea
lip open.

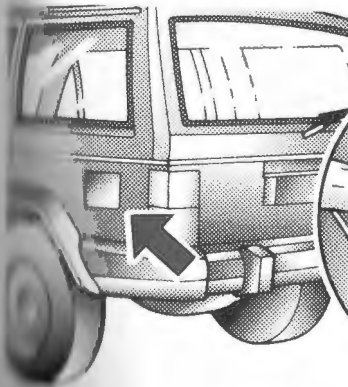

FUEL TANK FILLER CAP (GAS CAP) AND FUEL FILLER DOOR

To open, press on the left (leading) edge of the door and flip open.

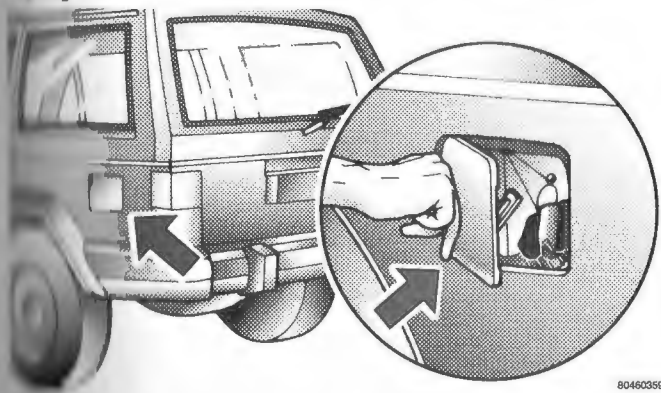

80460359

WARNING!

If you remove the gas cap too quickly, you could be injured. Gasoline could spray out of the filler neck, and could ignite if there is any spark or flame nearby. This is more possible when the vehicle is hot, as the pressure in the fuel tank is greater then. Remove the gas cap slowly. Never have any smoking materials lit in or near the vehicle when the cap is being removed or the tank filled.

- To remove the cap, turn counterclockwise.
- Place filler cap in holder on inside of fuel filler door.
- To replace the cap, insert it into the filler neck and tighten clockwise until at least three clicks are heard.

Fuel Tank Capacity

20.2 U.S. Gallons/ 75.7 Liters.

CATALYTIC CONVERTER

The catalytic converter requires the use of unleaded fuel only. Leaded gasoline will destroy the effectiveness of the catalyst as an emission control device. Under normal operating conditions, the catalytic converter will not require maintenance. However, you must keep the engine properly tuned to assure proper operation and prevent possible damage.

NOTE: Intentional tampering with emissions control systems can result in civil penalties being assessed against you.

As with any vehicle, do not park or operate this vehicle in areas where combustible materials such as grass or leaves can come in contact with a hot exhaust system.

A scorching odor may become evident if you continue to run a malfunctioning engine. The odor may indicate

severe and abnormal catalyst overheating. If this occurs, the vehicle should be stopped, the engine shut off and the vehicle allowed to cool. Service, including regular maintenance to manufacturer's specifications should be obtained immediately. To minimize the possibility of catalyst damage:

- Do not try to start the engine by pushing or towing the vehicle.
- Do not idle the engine with any spark plug wires disconnected or removed.
- Do not idle the engine for prolonged periods during very rough idle or malfunctioning operating conditions.
- Do not allow vehicle to run out of fuel.

CAUTION

Damage to the catalytic converter if the vehicle is not kept in proper tune. In the event of engine malfunction, the converter should be serviced promptly. Continuing to operate the vehicle with a severe malfunctioning engine may cause the converter to overheat, resulting in damage to the converter and vehicle.

If your vehicle should need engine service due to engine misfire or other loss of power, have the engine serviced promptly. Continuing to operate the vehicle with a severe malfunctioning engine may cause the converter to overheat. Overheating could result in damage to the converter and the vehicle.

CAUTION!

Damage to the catalytic converter can result if your vehicle is not kept in proper operating condition. In the event of engine malfunction have your vehicle serviced promptly. Continued operation of your vehicle with a severe malfunction could cause the converter to overheat, resulting in possible damage to the converter and vehicle.

If your vehicle should need service, especially involving misfire or other loss of performance, have the service done promptly. Continuing to operate your vehicle with a severe malfunction could cause the converter to overheat. Overheating could result in possible damage to the converter and the vehicle.

TRAILER TOWING AND CAMPERS

In this section you will find information on limits to the type of towing you can reasonably do with your Jeep vehicle. And you will find safety tips. Before towing a trailer carefully review this information to tow your load as efficiently and safely as possible.

To maintain warranty coverage, follow the requirements and recommendations in this manual concerning vehicles used for trailer towing.

Perform maintenance services as prescribed in the Maintenance Schedules section. When your vehicle is used for trailer towing, never exceed the gross axle weight rating (GAWR) by the addition of:

- The tongue weight of the trailer.
- The weight of any other type of cargo or equipment put in or on your Jeep vehicle.

Remember that everything put in or on the trailer adds to the load on your Jeep vehicle. Refer to the Jeep Vehicle Weight Capacities chart in the Specifications section of this manual.

Trailer Towing Warnings

WARNING!

Improper towing can lead to an injury accident. Follow these guidelines to make your trailer towing as safe as possible:

- Be sure a trailer is loaded heavier in front, with 60% to 65% of the weight in front of the axle(s). Loads balanced over the wheels or heavier in the rear cause the trailer to sway **severely** side to side which will cause loss of control of vehicle and trailer. Failure to load trailers heavier in front is the cause of many trailering accidents.
- Chrysler Corporation recommends separate trailer brakes for trailers in excess of 1,000 lbs. (453 Kg).
- Do **not** interconnect the hydraulic brake system of your vehicle with that of the trailer. This could cause inadequate braking and possible personal injury.
- Jeep vehicles equipped with Anti-Lock Brakes require an electrically-actuated trailer braking system.
- Do **not** connect a trailer lighting system directly to the lighting system of your vehicle. Use an approved trailer wiring harness. Failure to do so could damage the vehicle electrical system and/or result in personal injury.
- When hauling cargo or towing a trailer, do not overload your vehicle or trailer. Overloading can cause loss of control, poor performance or damage to brakes, axle, engine, transmission, steering, suspension, body structure or tires.

- It is recommended that all vehicle be factory installed dealer using factory approved parts are specifically engineered for performance in mind, including will be involved in an accident have been so engineered. Vehicle damage in a therefore be different.

Trailer and Tongue Weight
Gross Trailer Weight (GTW) trailer plus the weight of all equipment loaded on the trailer towing condition. The be to put your fully loaded trailer entire weight of the trailer r

parate trailer
(453 Kg).

ake system of
is could cause
nal injury.

Brakes requir
system.

directly to the
an approved
could damage
sult in person

er, do not over
ng can cause
mage to brake
suspension, both

- It is recommended that any hitches installed on your vehicle be factory installed, or installed by a Jeep dealer using factory approved parts. Factory approved parts are specifically engineered with your vehicle's performance in mind, including the possibility that it will be involved in an accident. Other hitches may not have been so engineered. Vehicle performance, including vehicle damage in an accident situation, may therefore be different.

Trailer and Tongue Weight

Trailer Weight (GTW) means the weight of the trailer plus the weight of all cargo, consumables and equipment loaded on the trailer when in actual under-way towing condition. The best way to measure GTW is to put your fully loaded trailer on a vehicle scale. The tongue weight of the trailer must be supported by the

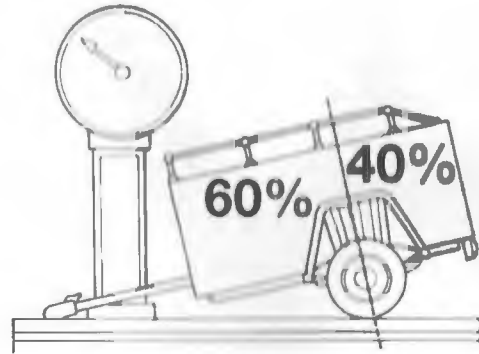

0030c090

Tongue Weight is the weight placed on the vehicle's trailer hitch by the trailer. Always load a trailer with 60% to 65% of the weight in the front of the trailer. This places 10% to 15% of the GTW on the tow hitch of your vehicle.

Trailer sway control and equalizing hitch required for tongue weights above 350 lbs.

Trailer Towing — Hitches

With a Class I Hitch, your vehicle can be equipped to tow trailers with a Gross Trailer Weight (GTW) of 2,000 lbs. (907 kg) maximum. Vehicles equipped with a rear step bumper are rated for a Class I Hitch.

With a Class III Hitch, your vehicle can be equipped to tow trailers with a Gross Trailer Weight (GTW) of 5,000 lbs. (2,268 kg) maximum. Tongue weight must be equal to at least 10% of GTW, but no more than 15% of GTW.

Trailer Towing Requirements

Your Jeep Cherokee may require extra equipment to safely and efficiently tow a trailer. Note the following requirements:

Tire Size P215/75R15

Class I Hitch (Light Duty) for towing trailers with a Gross Trailer Weight of up to 2,000 lbs. (907 kg) maximum.

2.5L engine with 5-speed manual transmission or any 4.0L engine/transmission combination.

Tire Size P215/75R15

Class III Hitch (Heavy Duty) for towing trailers with a Gross Trailer Weight of up to 5,000 lbs. (2,268 kg) maximum.

Engine 4.0L 6-Cylinder

Transmission Automatic Only

Tire Size P215/75R15 (Minimum)

Engine Cooling Heavy Duty

Battery Heavy Duty

Cooling System Heavy Duty

Spare Tire Full Size

Transmission Cooler Auxiliary Cooler Required

Axle Lubricant Synthetic

The direct connection of hydraulic brake lines from the vehicle brake system to the trailer system is not acceptable. Electrically-actuated brakes are necessary for vehicles equipped with the Anti-Lock Brake system.

Heavy trailer towing may also require breakaway electric trailer brakes, anti-sway devices or equalizing hitches for safe operation. Such devices are commonly required by state law.

Minimum Vehicle Requirements

Trailer Type

Flatbed Down and Low Profile

Up to 25 ft² (2.3m²)
or Less Frontal Area

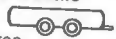

Up to 2,000 lbs. (907 kg)
also Small Boats,
Flatbed Trailers etc.

Other Trailer Types and Weights up to Full Box Shape

Up to 64 ft² (5.8m²)
Frontal Area





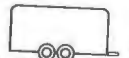

Up to 3,000 lbs.
(1,360 kg) GTW

Maximum Travel
Length:
15 ft (4.6m)



Always ensure vehicle payload should be reduced when towing a trailer. Total combined weight of trailer.

Minimum Vehicle Requirements for Trailer Towing

Trailer Type	Gross Trailer Weight	Tongue Weight (See Note 1)	Towing Pkg.	GCWR (Max.) (See Note 2)	Engine	Transmission	Steering	Battery	Cooling	Axle	Tire Size
Fold Down and Low Profile 10 ft (3.0m) Frontal Area  2,000 lbs. (907 kg) Small Boats, Trailers etc.	2,000 lbs. (907 kg) (Max.)	300 lbs. (91 kg) (Max.) 10 to 15% of GTW	Class 1 Hitch (Light Duty)	4x2 5,781 lbs. (2,627 kg)	4.0L	All	Power	Heavy Duty	All	All	P15/75 R15
				4x4 6,060 lbs. (2,754 kg)	2.5L	Manual 5 Spd ONLY					
	1,000 lbs. (453 kg) (Max.)	4x2 4x4 5,300 lbs. (2,409 kg)	2.5L	Auto 3 Spd. ONLY							
Other Trailer Types and Weights up to Full Box Shape 10 to 14 ft (5.8m ²) Frontal Area  5,000 lbs. (2,268 kg) GTW Maximum Travel Trailer Lengths: 12 to 17.9m  	5,000 lbs. (2,268 kg) (Max.)	750 lbs. (340 kg) (Max.)	Class III Hitch (Light Duty)	4x2 8,781 lbs. (3,983 kg) 4x4 9,060 lbs. (4,110 kg)	4.0L 6 cyl.	Auto. Trans. with Cooler	Power	Heavy Duty	Heavy Duty	All	P215/75 R15

1. The vehicle payload should be reduced by the tongue load (for a dead weight hitch) to keep the rear axle loading below GAWR (Gross Axle Weight Rating) of 2,700 lbs. (1,225 kg).

2. Total combined weight of trailer and tow vehicle.

Cooling System Tips — Trailer Towing

To reduce potential for engine and transmission overheating, take the following actions:

- **City Traffic** - When stopped, put transmission in neutral and increase engine idle speed.
- **Highway Driving** - Reduce speed.
- **Air Conditioning** - Turn off temporarily.
- See Cooling System Operating Information in the Service and Maintenance section of this manual for more information.

To reduce potential for automatic transmission overheating, shift to 3 (Drive 3) when driving in hilly areas or 1-2 (Drive 1-2) on more severe grades. Move the shift lever to the next lower position to eliminate excessive transmission shifting. This action will also reduce the possibility of transmission overheating and provide better engine braking.

NOTE: If your vehicle has an automatic transmission and you tow a trailer frequently, especially in hilly country or when the outdoor temperature is high, we recommend that you do one or both of the following:

- Change the transmission fluid at 15,000 mile (24,000 km) intervals.
- If your vehicle is not already equipped with an oil to air transmission cooler, have such a cooler installed on your vehicle.

CAUTION!

When pulling a heavy load or driving a fully loaded vehicle use a premium unleaded fuel to help prevent spark knock. If spark knock persists, lighten the load. Otherwise, engine piston damage may result.

Other restrictions apply to frontal area and tongue weight. Maximum Vehicle Requirements apply before towing a trailer.

HOW PLOW

Before using your vehicle to plow, contact your dealer for information about equipment. Ask whether equipment is needed for the specific plow you perform.

Always use Gross Vehicle Weight and Gross Axle Weight Rating (GAWR) to be sure your vehicle is in good condition for the equipment you use.

Plow plowing is not recommended for vehicles equipped with automatic transmission. The possibility of transmission

Other restrictions apply concerning trailer type, trailer frontal area and tongue weight. Carefully review the Minimum Vehicle Requirements chart in this section before towing a trailer.

SNOW PLOW

Before using your vehicle to plow snow, ask your Jeep dealer for information about factory approved plows and equipment. Ask whether vehicle modifications are needed for the specific plowing work you want to perform.

Discuss Gross Vehicle Weight Rating (GVWR) and Gross Axle Weight Rating (GAWR) limitations with your dealer to be sure your vehicle is in no way overloaded by the equipment you use.

Snow plowing is not recommended with the 2.5L engine when equipped with automatic transmission due to the possibility of transmission overheating, during severe

The following are minimum equipment requirements for your Cherokee if you intend to use a snow plow:

- Four Wheel Drive
- P215/75 R15 tires, inflated to 30 psi (207 kPa)
- Power steering
- Automatic transmission with fluid cooler
- Heavy-duty springs and shock absorbers (available through your Jeep dealer)
- Heavy-duty alternator and battery
- Heavy-duty cooling system
- Front Air Shocks (available through your Jeep dealer) to maintain level vehicle attitude.

It is best to operate your vehicle under normal driving conditions for at least 500 mi (805 km) before subjecting it to the stresses of snow plowing.

WARNING!

Attaching a snow plow to this vehicle could adversely affect performance of the airbag system in an accident. Do not expect that the airbag will perform as described earlier in this manual.

CAUTION!

With a snow plow mounted on your vehicle, do not exceed 40 mph (64 km/h) with the plow raised. Structure or suspension damage may result. Always lower the plow fully when the vehicle is parked.

CAUTION!

The weight of the plow, mounting hardware and related equipment must not exceed 380 lbs (172 kg). Never allow the weight of added equipment to increase the Gross Vehicle Weight beyond the GVWR number posted on the driver's door below the door latch. Damage to suspension or structure may result.

**(RECREATIONAL TOWING
ETC.)****4x4 Vehicles**

Use the following procedure
towing:

CAUTION!

- Internal damage to the front or rear wheel lift towing.
- It is necessary to follow the correct procedure to be certain that the transmission is in Neutral before recrea-
tional towing to prevent damage to internal part

Shift transmission into N

RECREATIONAL TOWING (BEHIND MOTORHOME, ETC.)

Trail Vehicles

Use the following procedure to prepare your vehicle for towing:

CAUTION!

- Internal damage to the transfer case will occur if a front or rear wheel lift is used when recreational towing.
- It is necessary to follow the steps listed below to be certain that the transfer case is fully in N (Neutral) before recreational towing to prevent damage to internal parts.

Shift transmission into N (Neutral).

2. Shift transfer case lever into N (Neutral).
3. Shift manual transmission into gear or automatic transmission into D (Drive) and make sure there is no vehicle movement.
4. Turn ignition key to the unlocked OFF position.
5. Shift automatic transmission into P (Park).
6. Attach vehicle to the tow vehicle with tow bar.

WARNING!

With the transfer case in N (Neutral) position, the vehicle could roll unexpectedly. The parking brake should always be applied when the driver is not in the vehicle.

2 Wheel Drive Vehicles

2-Wheel-Drive vehicles with Manual Transmission can be flat-towed without restriction for a distance of 50 miles if you:

- unlock the steering column by turning the ignition key to the OFF position
- move the transmission shift lever to the Neutral position.

If you are towing farther than 50 miles, prepare to stop hourly and run the engine of the towed vehicle to insure lubrication of the transmission rear bearings and bushings.

CONTENTS

- Hazard Warning Flasher
- If Your Vehicle Over Heats
- Changing A Flat Tire
- Jack And Lug Wrench Location
- Spare Tire Location
- Tire Changing Procedure
- Tire Changing Warnings
- Jump Starting Procedure
- Emergency Tow Hooks

WHAT TO DO IN EMERGENCIES

CONTENTS

- Hazard Warning Flasher139
- If Your Vehicle Over Heats140
- Changing A Flat Tire141
 - Jack And Lug Wrench Locations141
 - Spare Tire Location142
 - Tire Changing Procedure145
 - Tire Changing Warnings148
- Jump Starting Procedure148
- Emergency Tow Hooks150
- Towing A Disabled Vehicle151
 - Commercial Tow Truck Hookup151
 - Command-Trac With Ignition Key Available . . .153
 - Command-Trac With Ignition Key Not Available And Vehicle Unlocked153
 - Command-Trac With Ignition Key Not Available And Vehicle Locked153
 - Selec-Trac With Ignition Key Available153
 - Selec-Trac With Ignition Key Not Available And Vehicle Unlocked154

□ Selec-Trac With Ignition Key Not Available
And Vehicle Locked154

□ Emergency Towing — Transfer Case Cannot
Be Shifted To Neutral154

HAZARD WARNING FLASH
your vehicle's hazard warni
warning system. When you a
directional signals will flash
your vehicle is disabled on
other drivers to steer clear of
an emergency warning sys
the vehicle is in motion.

NOTE: With extended use
battery down.

HAZARD WARNING FLASHER

Your vehicle's hazard warning flasher is an emergency warning system. When you activate it, all front and rear directional signals will flash intermittently. Use it when your vehicle is disabled on or near the road. It warns other drivers to steer clear of you and your vehicle. This is an emergency warning system, not to be used when the vehicle is in motion.

NOTE With extended use the flasher may run your battery down.

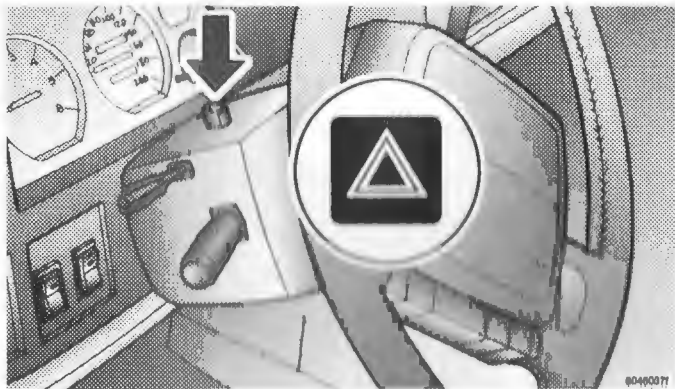

To activate the warning flasher, push the switch on the top of the steering column. Press the switch a second time to turn the flashers off

IF YOUR VEHICLE OVER HEATS

Your cooling system may temporarily overheat during severe operating conditions such as:

- climbing a long steep hill on a hot day,
- stopping after high speed driving,
- idling for long periods in traffic,
- or towing a trailer.

If the engine coolant temperature gauge needle goes into the red zone or the engine coolant warning light illuminates while you are stopped in traffic, move the transmission shift lever to N (Neutral) and turn the air conditioning OFF.

NOTE: If the engine coolant temperature gauge needle is in the upper half of the gauge, always let the engine idle for at least a minute before turning it off.

If the gauge needle doesn't start to drop, or the warning light doesn't go off, within a minute or two:

- Pull over to a safe place and stop the vehicle. Shift automatic transmission to P (Park), manual transmission to N (Neutral) and set the parking brake.
- **Don't turn off the engine.** Increase the engine speed slightly. Bring the idle speed back to normal after two or three minutes.

If the gauge needle doesn't start to drop, or the warning light does not go off, **turn off the engine** and proceed as follows.

Lift the engine hood. Check for coolant leaks at the radiator hoses, radiator or radiator overflow outlet. Check to see if all drive belts are intact. If you are losing coolant or a fan drive belt is broken or loose and/or the overheating condition persists, stop the engine until the cause of overheating is corrected. Following temporary

cooling system overload, p
duced speed after the o
ected. About ten minutes l

WARN

Hot coolant is under pressure. Do not touch it. If steam is coming out of the radiator, stop the engine and move well away from the engine. Do not open the radiator cap when the cooling system is hot. If the engine has cooled, turn the cap slowly. If you hear or see steam coming out of the cap, stop the system to cool further. See the Cooling System Check in the manual.

cooling system overload, proceed on the highway at a reduced speed after the overheating condition is corrected. About ten minutes later, resume normal driving.

WARNING!

Hot coolant is under pressure and can burn you badly. If steam is coming from the radiator, stand well away from the engine until you see no more signs of steam. Never loosen or remove the radiator cap when the cooling system is hot. When the system has cooled, turn the cap slowly just until the first stop. If you hear or see steam, get away and wait for the system to cool further. Follow the Emergency Cooling System Check described earlier in this manual.

CHANGING A FLAT TIRE

Jack And Lug Wrench Locations

The jack, jack handle and lug wrench are stored beneath the rear seat cushion. Loosen the wing nut to remove.

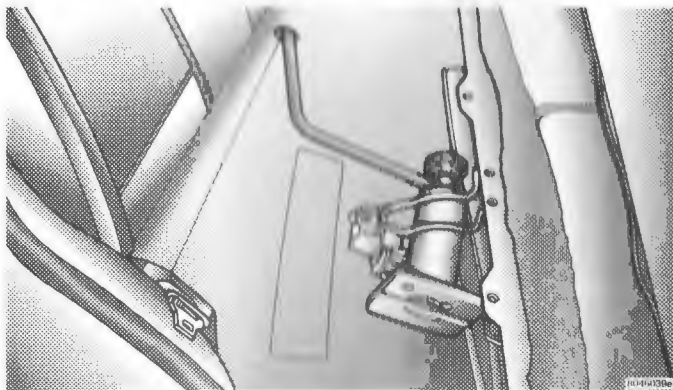

WARNING!

Always store the jack, lug wrench and spare, flat or damaged tire securely in the proper place. Never leave them loose in the vehicle where they could become dangerous projectiles during a quick stop or collision.

WARNING!

To avoid injury from using the jack, follow these important tips:

- Do not start engine while vehicle is on jack because engine vibration or wheel movement can cause vehicle to slip off jack

- Do not get under vehicle while it is on the jack. The vehicle could slide off, injuring anyone beneath it. Passengers should not remain in vehicle when you are changing wheels.

CAUTION!

The jack is for changing wheels on this vehicle only. Never use your vehicle jack on the bumpers, sills or underbody of your vehicle. Damage may result. Locate your vehicle jack only under an axle in the positions shown for Tire Changing Procedure.

Spare Tire Location**To Remove Spare Tire:**

1. Lift bottom part of the cover.
2. Loosen wing nut.

Remove tire cover and wing nut.

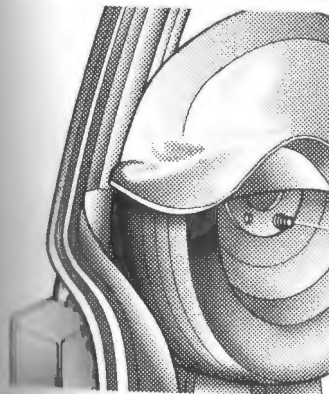

To replace Spare Tire:
1. Loosen wing nut.
2. Replace the tire cover.

Remove tire cover and wing nut.

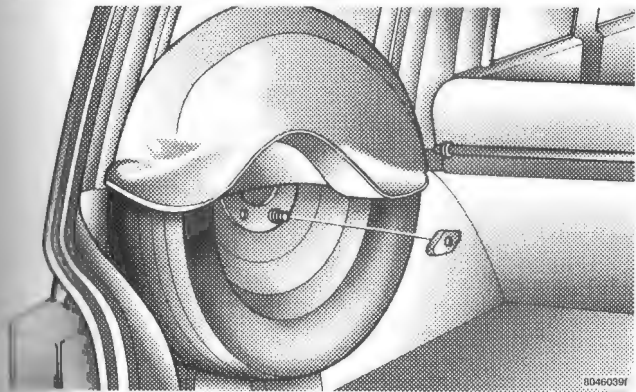

a. turn the tire cover inside out and place it on the top of the tire



Replace Spare Tire:
Replace the tire cover:

- b. begin to peel the sleeve down over the sides of the tire

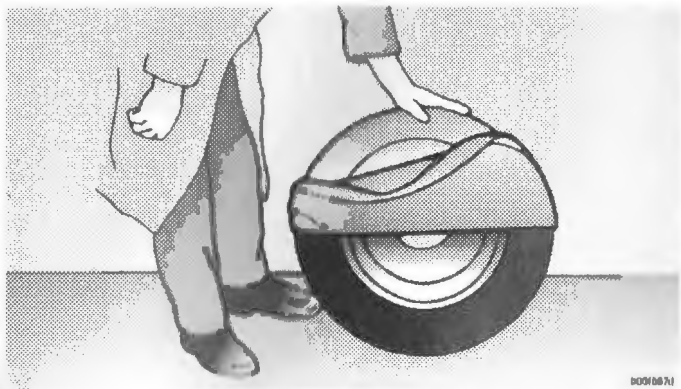

2. Place tire on the threaded rod and start wing nut but do not tighten fully.

NOTE: If you are stowing a full-size flat and your spare tire is a compact spare, you will have to reposition the threaded rod on the bracket. Slots are provided in the bracket to accommodate either tire size.

3. Pull the cover down firmly and tuck in place.
4. Tighten wing nut fully.

WARNING!

Temporary-use spare tires are for emergency use only. With these tires, do not drive more than 50 miles (80 km) or exceed 50 mph (80 km/h). Temporary-use spare tires have a total tread life of 3,000 miles (4 800 km). Be sure to follow the warnings which apply to your spare. Failure to do so could result in spare tire failure and loss of vehicle control.

Your Jeep vehicle is equipped with a compact spare tire or conventional spare tire. The compact spare tire pressure at 60 psi (41

Compact Spare Tire

Replace the compact spare tire as soon as possible.

Never drive your vehicle with a compact spare tire installed at any time.

Changing Procedure

Preparation

WARNING!

You can be injured or killed if you are too close to moving traffic on the road to avoid being hit while changing the wheel.

Your Jeep vehicle is equipped with either a Compact spare tire or conventional spare tire. Maintain Compact spare tire pressure at 60 psi (414 kPa).

Compact Spare Tire

• Replace the compact spare tire with a full-size tire as soon as possible.

• Never drive your vehicle with more than one compact spare installed at any time.

Tire Changing Procedure

Preparation

WARNING!

You can be injured or killed if you try to change a tire too close to moving traffic. Pull far enough off the road to avoid being hit when operating the jack or changing the wheel.

- Park on a firm, level surface well off the road, to provide ample work space. Place automatic transmission in P (Park) or manual transmission in R (Reverse), and stop engine. Set parking brake firmly and activate Hazard Warning Flasher. Get everyone out of the vehicle before you jack it up. If the jack should fall, someone in the vehicle could be hurt.

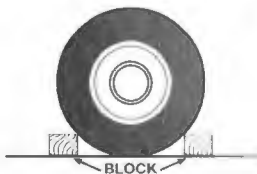

- Block front and rear of diagonally opposite tire. For example, if the right front tire is being changed, block the left rear wheel.

Instructions

1. Remove spare tire, jack and tools from stored location.
2. Loosen lug nuts one-half turn counterclockwise.

3. Locate the jack as shown. For the front axle (A) place under the axle near the wheel to be changed. For the rear axle (B) place under the axle as shown. Position jack handle on jack.

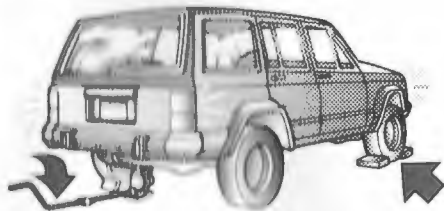
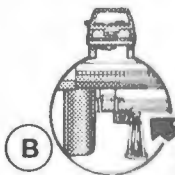
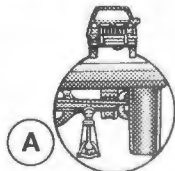

804603r0

4. Raise vehicle by turning jack handle clockwise until tire clears the ground.

WARNING!

Raising the vehicle higher than necessary can make the vehicle less stable. It could slip off the jack and hurt someone near it. Raise the vehicle only enough to remove the tire.

5. Remove lug nuts and wheel.

6. Position spare wheel/tire on vehicle and install lug nuts with cone-shaped end toward wheel. Lightly tighten nuts until they are equally snug, using a crisscross pattern. To avoid the risk of forcing the vehicle off the jack, do not tighten the nuts fully until the vehicle has been lowered.

7. Lower vehicle and remove the jack and wheel block.

8. Tighten lug nuts securely in crisscross pattern to 85-110 foot-pounds (115-149 N·m).

Secure jack, lug wrench, jack stands in the locations.

WARNING!

A loose tire or jack thrown forward could injure someone. Always stow the jack parts and wheel in the places provided.

Secure jack, lug wrench, jack handle and tire in proper positions.

WARNING!

A loose tire or jack thrown forward in a collision or hard stop could injure someone in the vehicle. Always stow the jack parts and the extra tire and wheel in the places provided.

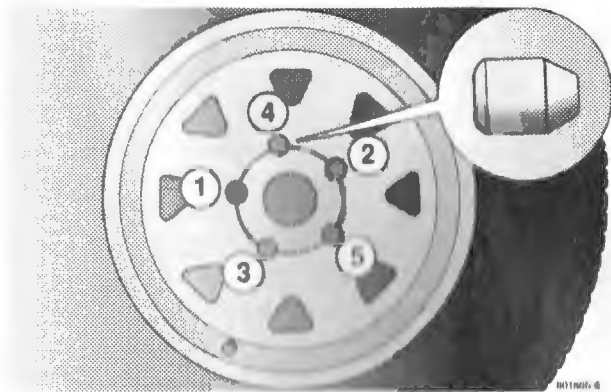

6

Tire Changing Warnings

WARNING!

Carefully follow these tire changing warnings to help prevent personal injury or damage to your vehicle:

- Always park on a firm, level surface as far from the edge of the roadway as possible before raising the vehicle.
- Block the wheel diagonally opposite the wheel to be raised.
- Apply the parking brake firmly before jacking.
- Never start the engine with the vehicle on a jack.
- Do not let anyone sit in the vehicle when it is on a jack.
- Do not get under the vehicle when it is on a jack.

- Failure to follow the Tire Changing Procedure may result in personal injury or damage to your vehicle.
- Only use the jack in the positions indicated.
- If working on or near a roadway, be extremely careful of motor traffic.

JUMP STARTING PROCEDURE

1. Wear eye protection and remove any metal jewelry such as watch bands or bracelets that might make inadvertent electrical contact.
2. When boost is provided by a battery in another vehicle, park that vehicle within booster cable reach but without letting the vehicles touch. Set parking brake, place automatic transmission in P (Park), manual transmission in N (Neutral) and turn ignition to OFF for both vehicles.
3. Turn off heater, radio and all unnecessary electrical loads.

4. Connect one end of a jumper cable to the negative terminal of the booster battery and the other end to the same cable to the positive terminal of the battery.

5. Connect the other cable, from the positive terminal of the booster battery and the positive terminal of the vehicle with the discharged battery, to a good contact on the engine.

6. Start the engine in the vehicle with the booster battery, let the engine idle a few minutes, then start the engine in the vehicle with the discharged battery.

7. When removing the jumper cables, do so in the reverse sequence exactly. Be careful of the engine.

1. Connect one end of a jumper cable to the positive terminal of the booster battery. Connect the other end of the same cable to the positive terminal of the discharged battery.

2. Connect the other cable, first to the negative terminal of the booster battery and then to the engine of the vehicle with the discharged battery. Make sure you have a good contact on the engine.

3. Start the engine in the vehicle which has the booster battery let the engine idle a few minutes, then start the engine in the vehicle with the discharged battery.

4. When removing the jumper cables, reverse the above sequence exactly. Be careful of the moving belts and fan.

WARNING!

Jump starting can be dangerous. To avoid personal injury or damage to electrical components in vehicle, observe the following warnings:

- Battery fluid is a corrosive acid solution and can burn or even blind you. Don't allow battery fluid to contact your eyes, skin, or clothing. Don't lean over a battery when attaching clamps. If acid splashes in eyes or on skin, flush the area immediately with large amounts of water.
- Do not use a booster battery or any other booster source that has a greater than 12 volt system, i.e. do not use a 24 volt power source.

- Never attempt to jump start a discharged battery that is frozen, because it could rupture or explode during jump starting.
- Be sure your vehicle is not touching the jump start vehicle.
- Observe all Battery Warnings located in Section 7 of this manual while jump starting your vehicle.

WARNING!

Do not attempt to push or tow your vehicle to get it started. Unburned fuel could enter the catalytic converter and, once the engine has started, ignite and damage the converter and vehicle.

EMERGENCY TOW HOOKS

If your vehicle is equipped with tow hooks, two are mounted in front and one in rear.

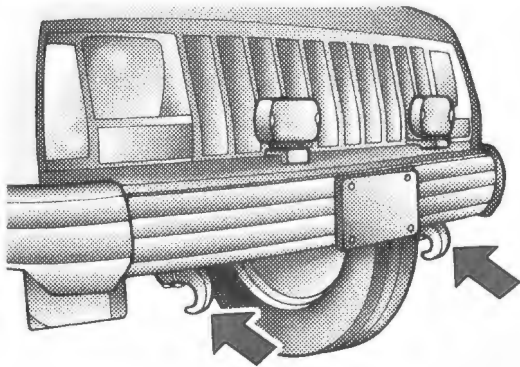
**WAR**

Stand clear of vehicles and tow hooks. Tow straps and hooks can cause serious injury.

CAU

Tow hooks are for emergency use only. Do not use tow hooks to tow a vehicle stranded off road. Do not use tow hooks for hookup or high speed towing. Improper use can damage your vehicle.

TOWING A DISABLED VEH

Four-wheel-drive vehicles should be towed with wheels supported by dollys. Other towing methods will avoid potential

WARNING!

Hand clear of vehicles when pulling with tow hooks. Tow straps and chains may break, causing serious injury.

CAUTION!

Tow hooks are for emergency use only, to rescue a vehicle stranded off road. Do not use tow hooks for tow truck hookup or highway towing. You could damage your vehicle.

TOWING A DISABLED VEHICLE

Four-wheel-drive vehicles should be towed on a flatbed or with wheels supported by a dolly. Either of these methods will avoid potential damage to the transfer case.

It may be necessary to tow a 4WD vehicle with the front raised and the rear wheels on the ground. Insure that the transfer case is in Neutral (N) and the transmission is either in Park (automatic transmission) or in gear (manual transmission).

CAUTION!

Do not disconnect rear prop shaft because fluid will leak from the transfer case and damage internal parts.

6**Commercial Tow Truck Hookup**

Tow hooks or chains must not be attached to the bumper or universal joints.

- Attach a J-hook to the left side of the axle as shown (A). Position the sling tow bar close to the front bumper.

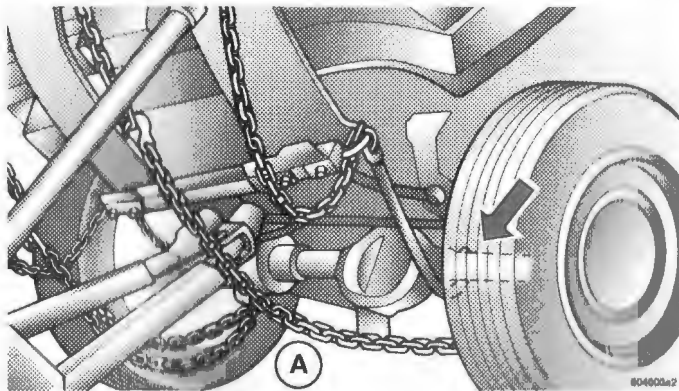

- Attach right side by positioning chain over the axle and hooking as shown to structural member (B). Attach safety chains as shown.

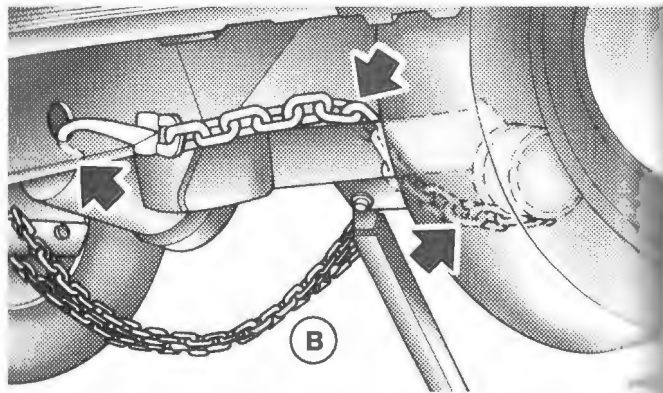

CAUTION!

Internal damage to the transfer case will occur if front or rear wheel-lift is used when towing.

Command-Trac With Ignition

Manual Transmission
 Turn the ignition key to the OFF position. Shift the transfer case to N (Neutral).

Automatic Transmission
 Turn the ignition key to the OFF position. Shift the transfer case into P (Park) and transfer case to N (Neutral).

Command-Trac With Ignition

Vehicle Unlocked
Manual Transmission
 Shift the transmission into gear (Neutral).

Automatic Transmission
 Shift the transmission into P (Park) and transfer case to N (Neutral).

Command-Trac With Ignition Key Available**Manual Transmission**

Turn the ignition key to the OFF position to unlock the steering column. Shift the transmission into gear and the transfer case to N (Neutral).

Automatic Transmission

Turn the ignition key to the OFF position to unlock the steering column and gear shift linkage. Shift transmission into P (Park) and transfer case to N (Neutral).

Command-Trac With Ignition Key Not Available And Vehicle Unlocked**Manual Transmission**

Shift the transmission into gear and the transfer case to N (Neutral).

Automatic Transmission

Check that transmission is in P (Park), and shift transfer case to N (Neutral).

Command-Trac With Ignition Key Not Available And Vehicle Locked**Manual And Automatic Transmissions**

Place a dolly under the rear wheels and tow vehicle with the front end raised.

Selec-Trac With Ignition Key Available

Turn ignition key to OFF position to unlock steering column and gear shift selector linkage. Shift transmission to P (Park) and transfer case to N (Neutral).

CAUTION!

Internal damage to the transfer case will occur if a sling restricting wheel movement is used when towing.

Selec-Trac With Ignition Key Not Available And Vehicle Unlocked

Check that transmission is in P (Park), and shift the transfer case to N (Neutral).

Selec-Trac With Ignition Key Not Available And Vehicle Locked

Place a dolly under the rear wheels and tow vehicle with front end raised.

Emergency Towing — Transfer Case Cannot Be Shifted To Neutral

Whenever an emergency situation arises and the transfer case cannot be shifted to Neutral (N), the following method can be used to tow a Jeep vehicle.

1. Turn ignition switch to the unlocked (OFF) position.
2. Shift transmission to the Neutral position.
3. Connect vehicle to tow vehicle by raising the front wheels and placing the rear wheels on a dolly.

CAUTION!

If the vehicle must be towed with the front wheels on the ground, the ignition key must be turned to the OFF position to unlock the steering column. The steering column lock is not strong enough to withstand the shock transmitted from the front wheels while towing. Also, before towing the vehicle with the rear wheels lifted, secure the steering column with a steering wheel clamping device designed for towing service.

CONTENTS

- Engine Compartment
- Onboard Diagnostic System
- Maintenance Procedures
- Guidelines For Checking
- Disposing Of Used Engine Oil
- Engine Oil
- Engine Oil Filter
- Cooling System
- Engine Air Cleaner Filter

MAINTAINING YOUR VEHICLE

CONTENTS

■ Engine Compartment	157	□ Spark Plug Removal	171
■ Onboard Diagnostic System (OBD II)	158	□ Hydraulic Clutch Fluid	171
■ Maintenance Procedures	158	□ Manual Transmission	172
Guidelines For Checking Fluid Levels	158	□ Automatic Transmission	173
Disposing Of Used Engine Fluids	159	□ Transfer Case	176
Engine Oil	160	□ Battery	177
Engine Oil Filter	164	□ Power Steering Fluid	180
Cooling System	165	□ Windshield Washer Fluid	181
Engine Air Cleaner Filter	170	□ Windshield Wipers	182

- Rear Window Wiper182
- Brake System183
- Air Conditioning185
- Front/Rear Axle Fluid187
- Driveline And Steering Component Lubrication188
- Selection Of Lubricating Grease188
- Body Lubrication189
- Appearance Care And Protection From Corrosion189
- Bulb Replacement192
 - Headlights192
 - Side Marker Lights193
 - Front Park/Turn Signal Light Replacement193

- Backup, Rear Turn Signal, Side Marker And Taillight Replacement194
- Center High-Mounted Stoplamp194
- Replacement Bulbs194
- Electrical Power Distribution Center194
- Relays200
- Fuse Panel200
 - Electrical Failure200
- General Specifications200
- Recommended Fluids, Lubricants And Genuine Parts200
 - Chassis200
 - Engine200
 - Body200

ENGINE COMPARTMENT
WINDSHIELD
RESERVE

BATTERY



ENGINE COMPARTMENT

WINDSHIELD SOLVENT
RESERVOIR

ENGINE OIL
DIPSTICK

AUTOMATIC
TRANS. DIPSTICK

BRAKE MASTER
CYLINDER RESERVOIR

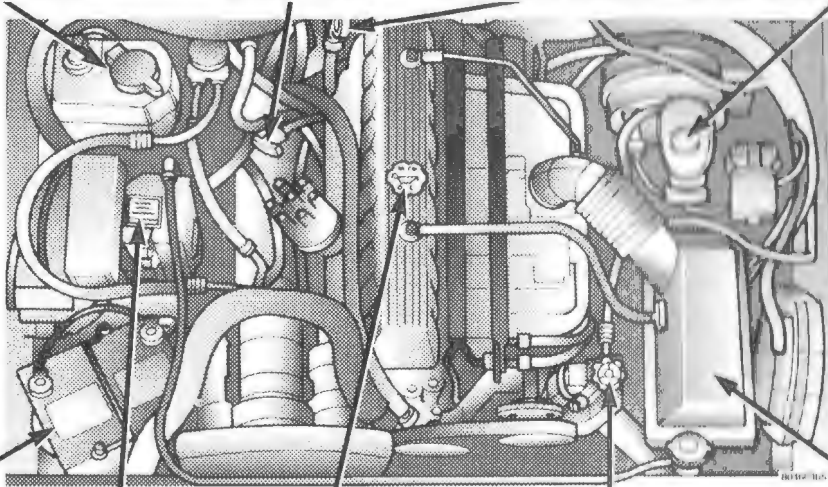

BATTERY

COOLANT
RESERVOIR

ENGINE OIL
FILL CAP

POWER STEERING
RESERVOIR/DIPSTICK

AIR CLEANER
HOUSING

ONBOARD DIAGNOSTIC SYSTEM (OBD II)

To meet new government regulations and promote cleaner air, your vehicle is equipped with a sophisticated onboard diagnostic system called OBD II. This system monitors the performance of the emissions, engine, and automatic transmission control systems. When these systems are operating properly, your vehicle will provide excellent performance and fuel economy, as well as engine emissions well within current government regulations.

If any of these systems require service, the OBD II system will turn on the Check Engine Light. It will also store diagnostic codes and other information to assist your service technician in making repairs. Although your vehicle will usually be driveable and not need towing, see your dealer for service as soon as possible.

CAUTION!

Prolonged driving with the light on could cause further damage to the emission control system. It could also affect fuel economy and driveability. The vehicle must be service before any state emissions tests can be performed.

If the light is flashing, severe catalytic converter damage and power loss will soon occur. Immediate service is required.

MAINTENANCE PROCEDURES

Guidelines For Checking Fluid Levels

1. Use only fluids and lubricants specified in the **Recommended Fluids, Lubricants and Genuine Parts** section located in the back of this manual.

2. Maintain maximum cleanliness. Do not provide chemical or mechanical cleaning. Oil and dirt from rags will severely damage the fluid and can cause component failure or injury, such as the result of a fire.

3. Check fluids at the proper temperature. Change as temperature changes.

4. Observe operating instructions. Do not be operating for an extended period.

5. Check both sides of a dipstick.

6. Position the vehicle on a level surface.

When checking a fluid through a manual transmission, the dipstick should be at the bottom of the dipstick when the unit is COL

3. **Maintain** maximum cleanliness. Fluids lubricate parts or provide chemical or mechanical action. Dirt, water or lint from rags will severely reduce the effectiveness of a fluid and can cause component damage or a personal injury, such as the result of using contaminated brake fluid.

4. Check fluids at the prescribed temperatures. Fluid levels change as temperature changes.

5. Observe operating instructions. Some components must be operating for an accurate reading to be taken.

6. Check both sides of a dipstick for accurate reading.

7. Position the vehicle on a level surface to avoid false readings.

8. When checking a fluid through a fill plug hole, such as on a manual transmission, transfer case or axle, fluid level should be at the bottom of the fill hole or slightly above when the unit is COLD. If low, **add fluid in small**

amounts to raise the level. When the unit is WARM, fluid may ooze out of the filler hole. This is acceptable. **Fluid should not gush out.**

8. Never overfill. Too much water weakens a battery or anti-freeze protection. Too much oil causes excess heat and foaming which can cause loss of fluid through the vent tubes, blown seals or damage from loss of fluid or lubricant breakdown.

9. Periodically observe the area where you normally park your vehicle. If you notice any fluid spots on the ground, check the fluid/lubricant levels of your vehicle. If the spotting persists, see your dealer. During the summer, spotting may result from water condensing in vehicles equipped with air conditioning. This is normal.

Disposing of Used Engine Fluids

Care should be taken in disposing of the used engine fluids from your vehicle. Used fluids, indiscriminately discarded, can present a problem to the environment.

Contact your local dealer, service station, or governmental agency for advice on how and where used fluids can be safely discarded in your area.

Engine Oil

Selection Of Engine Oil

For best performance and maximum protection for all engines under all types of operation, only engine oils should be selected that meet the oil quality certification and viscosity requirements as follows:

Engine Oil Identification Symbol

There is a oil symbol to aid you in selecting the proper engine oil



Viscosity

Multi-viscosity oils protect the engine over a wide range of operating temperatures and driving conditions and therefore can be used all year round. Select oil viscosity according to the lowest air temperature expected before the next oil change using the engine oil viscosity chart

This symbol on the front of an oil container means that the oil has been certified by the American Petroleum Institute (API) to meet all the lubrication requirements specified by Chrysler Corporation.

ENGINE OIL VISCOSITY

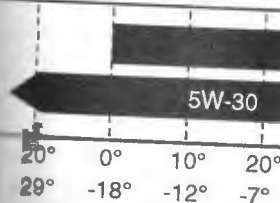

Temperature range anticipated

...ants which do not have
... mark and the correct
... should not be used.

... Added to Engine Oil
... recommended that no other
... oil approved for use

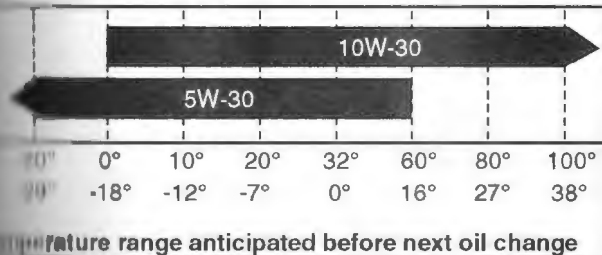
ENGINE OIL VISCOSITY GRADES

80183418

Oil which do not have both the engine oil certification mark and the correct viscosity grade number should not be used.

Materials Added to Engine Oils

It is recommended that no other materials be added to the engine oil approved for use in this vehicle.

Frequency Of Oil Changes

Road conditions as well as your kind of driving affect the interval at which your oil should be changed. Check the following to determine if any apply to you:

- Frequent short trip driving less than 5 miles (8 km)
- Frequent driving in dusty conditions
- Frequent trailer towing
- Extensive idling
- More than 50% of your driving is at sustained high speeds during hot weather, above 90°F (32°C)
- Off road driving
- Desert operation

If any of these apply to you then change your engine oil every 3,000 miles or 3 months, whichever comes first.

If none of these apply to you then change your engine oil every 7,500 miles or 6 months, whichever comes first.

CAUTION!

Do not overfill the crankcase. This will cause oil aeration and loss of oil pressure.

Check Engine Oil

Check the oil regularly with the vehicle on level ground. If the engine is warm, allow time for oil to drain into the crankcase before checking the level. The oil level should fall between the safe range marks on the dipstick. If the oil level is at the ADD mark, add 1 U.S. qt./0.95L.

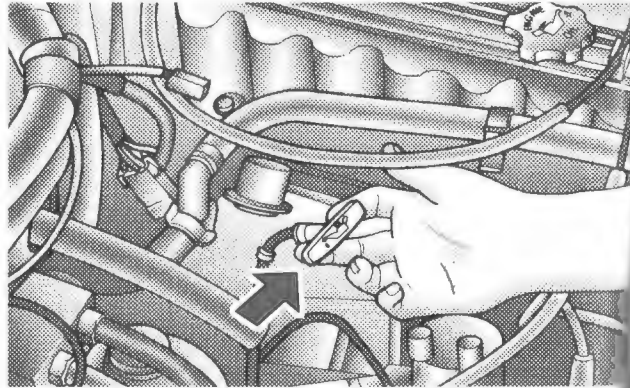

Capacity

- **4-Cyl. Engine:**
4 U.S. qts./3.8 Liters (including filter)
- **6-Cyl. Engine:**
6 U.S. qts./5.7 Liters (including filter)

After oil change, check oil level u
oil as necessary to bring level to
dipstick.

Add Engine Oil

Add oil at the oil filler cap. Keep
wiping up any spilled oil.

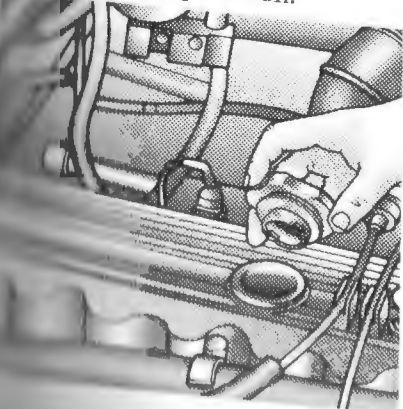

CAUTION!

An Oil Pressure Warning Light is located on the instrument cluster. If the light glows or flashes on and off, stop your vehicle immediately. Check the oil level and add oil if necessary. If the oil is not low, contact your dealer. Operating the engine when the oil level or oil pressure is low can damage the engine.

Drain Engine Oil

After the engine reaches operating temperature, turn off the ignition and allow the oil to drain back into the oil pan. This will assure complete removal of used oil contaminants.

After an oil change, check oil level using the dipstick. Add oil as necessary to bring level to the FULL mark on the dipstick.

Wash Engine Oil

Wash oil at the oil filler cap. Keep the engine clean by wiping up any spilled oil.

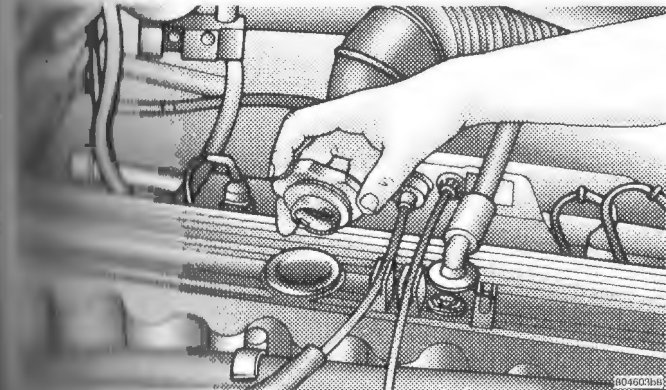

Remove the engine oil drain plug and allow oil to drain.

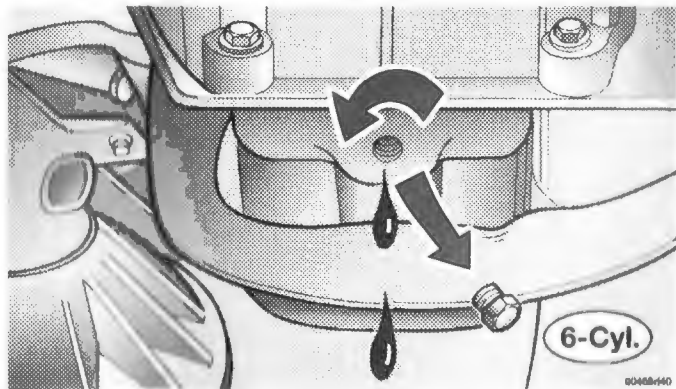

NOTE: Do not allow used engine oil to drain on the ground. To prevent serious pollution problems, collect the used oil and dispose of it properly.

Engine Oil Filter

Filter Changes

The engine oil filter should be replaced with a new filter at every oil change.

Change Oil Filter

Turn filter counterclockwise to remove.

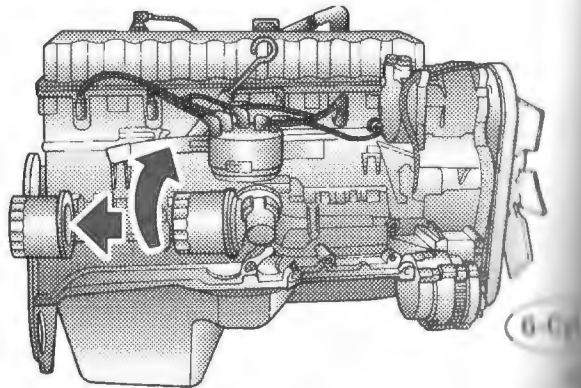

When installing a new filter, block filter mount and coat lightly with oil. **Hand-tighten** then clockwise past the point contacts the engine block filter.

NOTE: The oil filter should be changed.

Be sure to check for leaks by running.

Recommended Fluids, check of this manual.

Cooling System

Coolant Level Check

Check coolant at least once a month. Check the level when

When installing a new filter, be sure to clean the engine block filter mount and coat the rubber seal on the filter with oil. **Hand-tighten only.** Tighten the filter to one clockwise past the point where the filter gasket seats to the engine block filter mount.

Oil The oil filter should be changed every oil change.

Be sure to check for leaks by running the engine until it warms.

See **Recommended Fluids, Lubricants & Parts**, at the end of this manual.

Cooling System

Coolant Level Check

Check coolant at least once a month or more often in hot weather. Check the level when the engine is at normal

operating temperature. Check the coolant level only in the coolant recovery bottle. The coolant level must be at the FULL mark or above the ADD mark on the bottle.

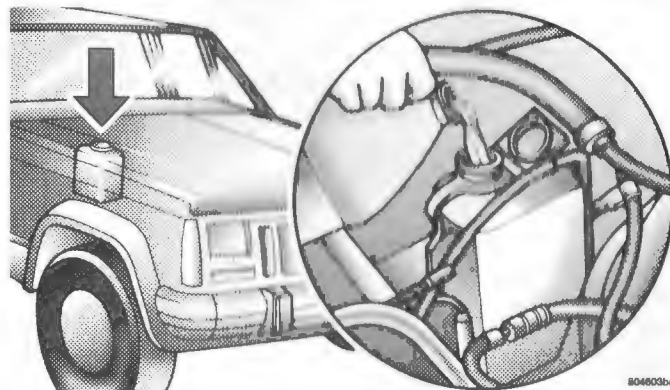

See your dealer if the coolant level drops quickly.

Emergency Cooling System Check — All Engines

WARNING!

Hot coolant is under pressure and can burn you badly. To guard against bodily injury from hot coolant, do not check coolant level at the radiator when the engine is hot. If an emergency requires a coolant level check at the radiator, proceed as follows:

1. Stop the engine and raise the hood.
2. Let the engine cool at least 15 minutes or until the radiator cap is cool enough to touch without burning your hand.
3. Place a heavy rag or towel over the radiator cap and turn it counterclockwise to the first stop to release the coolant system pressure. **Do not press down on cap.**

4. Only after all pressure has escaped, push down on the cap and continue to turn it counterclockwise to the second stop, then remove the cap.

5. The coolant should be filled to the bottom of the filler neck and also between the ADD and FULL marks on the coolant recovery bottle.

6. Add coolant, if necessary, to the coolant recovery bottle.

7. Install the radiator cap.

8. Obtain corrective service immediately to determine the cause of overheating.

Recommended Coolant

Chrysler Corporation vehicles have been designed to operate on Ethylene Glycol based coolant. Ethylene glycol based coolants are the only type recommended for use in your Chrysler Corporation vehicle.

Adding Coolant

Under normal conditions, add coolant only to the coolant

Coolant Capacity:**4 Cyl. Engine**

Dry capacity: 10 U.S. qts./

6 Cyl. Engine

Dry capacity: 12 U.S. qts./

NOTE: *Includes 2.3 U.S. bottle.

Adding Coolant

Under normal conditions, check coolant level and add coolant only to the coolant recovery bottle.

Coolant Capacity:

4 Cyl. Engine

Dry capacity: 10 U.S. qts./9.5L*

6 Cyl. Engine

Dry capacity: 12 U.S. qts./11.4L*

NOTE: *Includes 2.3 U.S. qts./2.2L for coolant recovery bottle.

Draining Engine Coolant — All Engines

WARNING!

Do not open engine block drain when system is hot or under pressure as serious burns from coolant may occur.

1. When draining the cooling system, leave the radiator cap in place. This will allow all fluid, including that in coolant recovery bottle, to drain from the system.
2. Open radiator draincock.

3. Remove engine block drain plug(s).

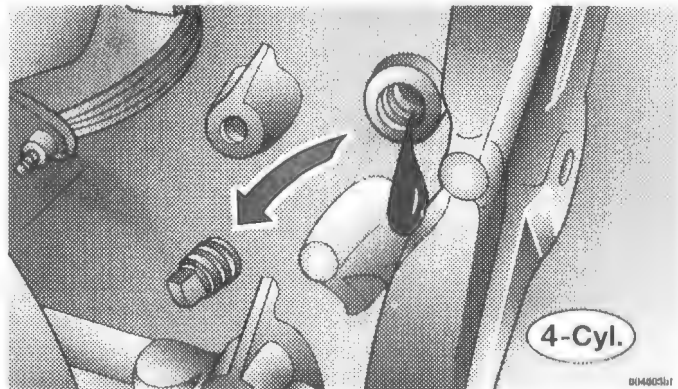

The 4-Cyl. engine drain plug is located on the lower left rear of the block.

The 6-Cyl. engine drain plug is located on the lower left side of the block.

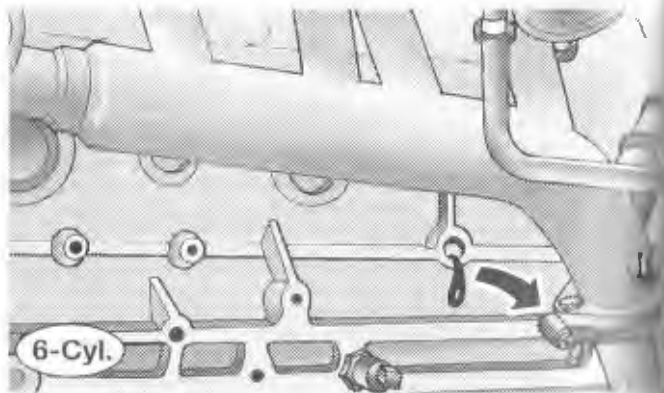

Clean the threads on the engine block drain plug and coat them with pipe thread sealer before installation.

Disposal of Used Engine Coolant

ethylene glycol based engine coolant is a hazardous substance requiring proper disposal by local authorities to determine the proper disposal method for your community. Do not store ethylene glycol based coolant in open containers or spill it on the ground. Prevent children from playing with coolant. If ingested by a child, seek medical attention immediately. Clean up any spills immediately.

Draining the Coolant System

The engine must be off and cool before draining the coolant system. Remove radiator and coolant reservoir caps. Slowly drain the coolant from the radiator until the level is at the bottom of the radiator. Then slowly drain the coolant from the reservoir until the level is at the bottom of the reservoir. Mark the level on the bottle.

Disposal of Used Engine Coolant

Used ethylene glycol based engine coolant is a regulated substance requiring proper disposal. Check with your local authorities to determine the disposal rules for your community. Do not store ethylene glycol based engine coolant in open containers or allow it to remain in puddles on the ground. Prevent ingestion by animals and children. If ingested by a child, contact a physician immediately. Clean up any ground spills immediately.

Filling Coolant System

1. Engine must be off and cool.
2. Remove radiator and coolant bottle caps.
3. Fill slowly at radiator until full.
4. Fill slowly at coolant recovery bottle until coolant is at FULL mark on the bottle.

5. Start the engine and operate until warm. Be sure to place the heater control in HEAT position. Check fluid level in radiator and add coolant if necessary.

6. Install radiator and coolant recovery bottle caps. Check system for leaks.

7. Stop the engine and allow to cool.

8. Check the coolant level in the coolant bottle and add if necessary. See step 4 for level check instructions.

CAUTION!

Do not install a fine mesh bug screen in front of the condenser and radiator that will restrict airflow and result in overheating. Periodically remove bugs and foreign matter from the condenser and radiator fins.

Engine Air Cleaner Filter

WARNING!

The air cleaner can provide protection in the case of engine backfire. Do not remove the air cleaner unless it is necessary for repair or maintenance. Make sure that no one is near the engine compartment before starting the vehicle with the air cleaner removed. Failure to do so can result in serious personal injury.

Unsnap the clips on two sides of the air cleaner cover. Slide the cover so that the tabs on the cover clear the slots in the filter housing. Remove the filter as shown.

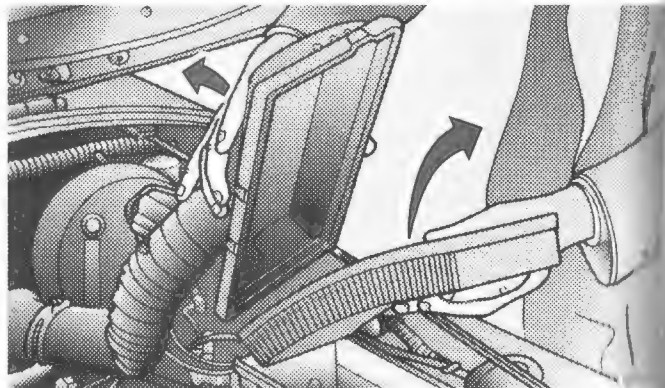

NOTE: The engine air cleaner filter should be replaced only at the intervals shown on the Maintenance Schedule. It is not necessary to inspect the filter at any other time. You won't learn anything from visual inspection, and the filter element will be more efficient if the seal is not broken.

Spark Plug Removal

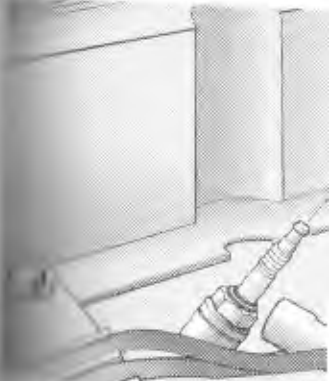

Spark Plug Recommendation
Refer to the Vehicle Emission
Label in the engine compartment.

Spark Plug Removal

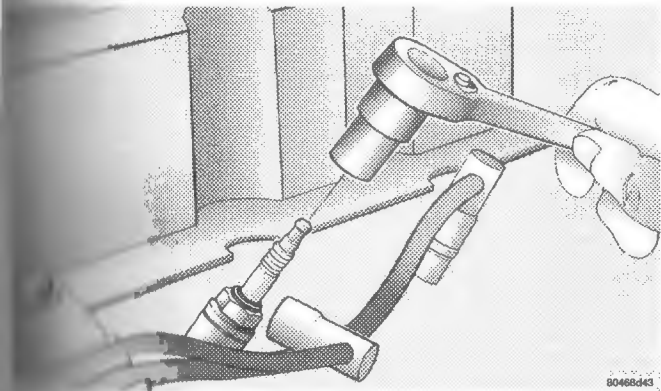

Spark Plug Recommendation

Refer to the Vehicle Emission Control Information label in the engine compartment.

Spark Plug Gap

0.9mm (.035 inch)

When replacing plugs, do not damage electrode tip and avoid overtightening. Recommended torque is 26 to 30 ft-lbs. (35 to 40 N·m).

Hydraulic Clutch Fluid

The clutch hydraulic system is a sealed maintenance-free system. In the event of leakage or other malfunction, the system must be replaced.

Manual Transmission

Checking Fluid Level

Remove fill plug. Fluid should be at the bottom of filler hole.

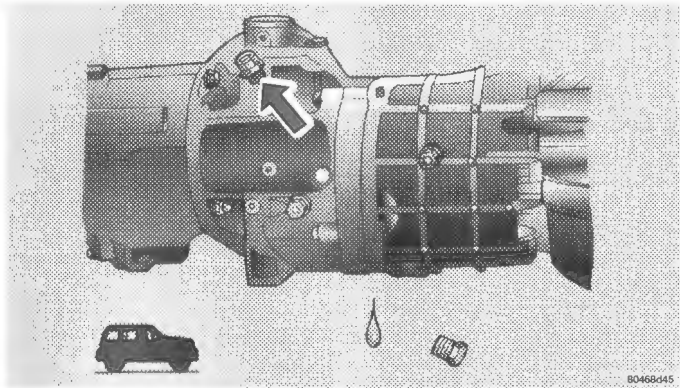

Adding Fluid

Fluid should be added at the filler hole until fluid begins to run out of hole.

Recommended Fluid

Fluid Type: Use only Mopar Gear Lubricant (P/N 4549624) or equivalent SAE 75W-90 API-GL5 grade.

Draining Fluid

First remove fill plug (B), then drain plug (C). Allow the fluid to drain into a container.

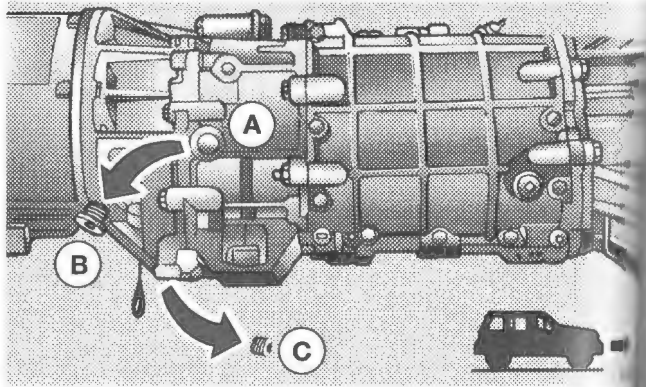

Filling Manual Transmission
When filling the manual transmission, first install plug (C) or until fluid runs out of filler hole (A) or until fluid runs out of plug (B).

Automatic Transmission

Checking Fluid Level (Typical)
Check the fluid level while the engine is running at normal operating temperature. This occurs after approximately 10 minutes of driving. At normal operating temperature, the fluid cannot be held comfortably.

Filling Manual Transmission

When filling the manual transmission after it has been drained, first install plug (C). Fill to the bottom of the dipstick hole (A) or until fluid runs out of the hole. Install plug (B).

Automatic Transmission

Checking Fluid Level (Typical)

Check the fluid level while the transmission is at normal operating temperature. This occurs after at least 15 miles (24 km) of driving. At normal operating temperature the fluid cannot be held comfortably between the fingertips.

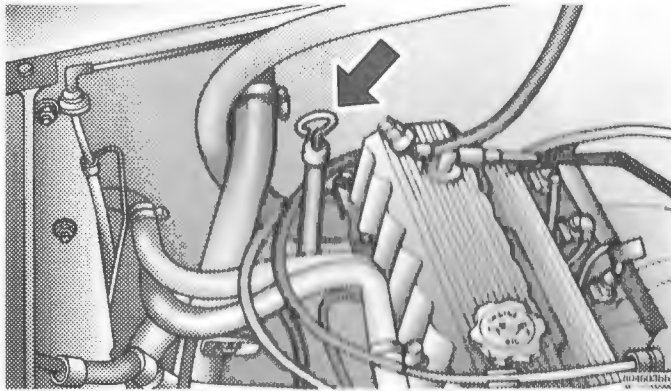

1. Operate engine at idle speed and normal operating temperature.
2. Place vehicle on level surface. Block wheels to prevent vehicle movement. Apply parking brake fully and depress the brake pedal. Move gearshift lever through all ranges. Shift to P (Park) (4.0L only) or shift to N (Neutral) (2.5L only).
3. Remove the dipstick, wipe clean and insert fully. Remove dipstick again and note fluid level on both sides. Fluid level should be between the two holes at normal operating temperature. If fluid is low, add as required into the dipstick tube. Do not overfill.
4. Check for leaks. Release parking brake.

NOTE: If necessary to check the transmission below operating temperature, the fluid level should be approximately at the ADD mark with the fluid at approximately 75°F (24°C) (room temperature).

If the fluid level is correctly established at room temperature, it should be at the full mark on the dipstick when the transmission reaches normal operating temperature (170°F or 77°C). Remember, it is best to check the level at normal operating temperature.

Fluid Capacity

- 4.0L = 17 U.S. pints/8 liters total for dry fill.
- 2.5L = 14 U.S. pints/6.6 liters total for dry fill.

Approximately 4 U.S. quarts/3.8 liters required for periodic fluid change as specified in Maintenance Schedule.

Recommended Fluid

4.0L Engine

McPARR Automatic Transmissi

Equivalent labeled DEXRON®

CAUTION

Never overfill the automatic transmission. Overfilling and loss of fluid through the seal malfunction, may result.

Adding Fluid (Typical)

Use a long-necked funnel inse

ed Fluid

Automatic Transmission Fluid (P/N 4773590) or
 labeled DEXRON® III MERCON® fluid.

CAUTION!

Fill the automatic transmission. Foaming
 fluid through the vent or filler tube, and
 a, may result.

l (Typical)

Checked funnel inserted into the dipstick tube.

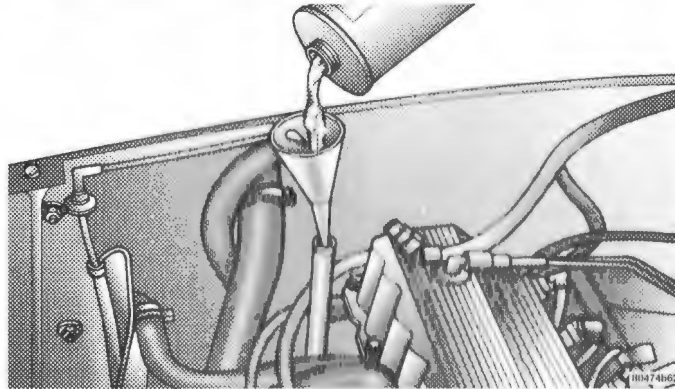

Add just enough fluid to fill the transmission to the
 proper level. It takes only 1 U.S. pt./0.5L. of fluid to raise
 the level from ADD to FULL when fluid is at normal
 operating temperature.

Transfer Case

Fluid Level Check

Lubricant should be level with the bottom of the fill hole (A).

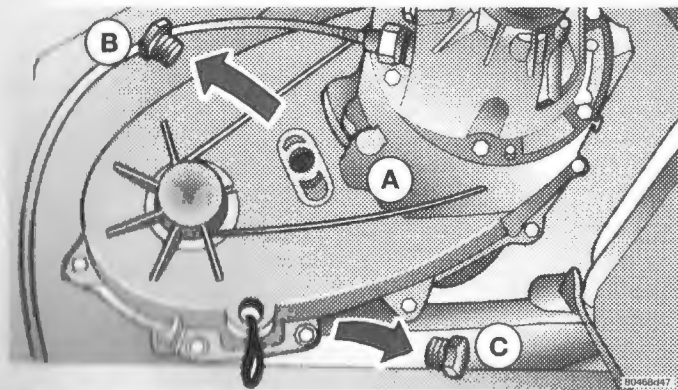

Adding Fluid

Only at filler hole until fluid runs out of the hole.

Draining Fluid

First remove fill plug (B), then drain plug (C). Recommended tightening torque for drain and fill plugs is 30 to 40 foot-pounds (41 to 54 N·m).

CAUTION!

When replacing plugs, do not overtighten. You could damage them and cause them to leak.

Recommended Fluid

Mopar Automatic Transmission Fluid or equivalent labeled Dexron® III or Mercon®.

Fluid Capacity

Selec-Trac

2.85 U.S. pints/1.3L

Command-Trac

2.2 U.S. pints/1.0L

Maintenance After Off-Pav

WARN

- After extended operation in similar dirty conditions, clean brake linings, and axle assembly as soon as possible. Remove abrasive material from brake pads. Unpredictable braking may result.
- Following off-road usage, inspect underbody of your vehicle for damage. Check suspension components, steering and drive shafts, and torque required, to torque required. Also check for vegetation or brush that may be present or conceal damage to tires, axle pinion seals,

Maintenance After Off-Pavement Driving



WARNING!

- After extended operation in mud, sand, water, or similar dirty conditions, have your brake drums, brake linings, and axle joints inspected and cleaned as soon as possible. This will prevent any abrasive material from causing excessive wear or unpredictable braking action.
- Following off-road usage, completely inspect the underbody of your vehicle. Check tires, body structure, steering, suspension and exhaust system for damage. Check threaded fasteners for looseness, particularly on the chassis, drivetrain components, steering and suspension. Retighten, if required, to torque values specified in the Repair Manual. Also check for accumulations of vegetation or brush that could become a fire hazard or conceal damage to fuel lines, brake hoses, axle pinion seals, and propeller shafts.

Battery

The low-maintenance battery may require the addition of water at intervals depending on vehicle usage. In temperatures up to 90°F (32°C), check the battery fluid level at least every 12 months or 15,000 miles (24 000 km). At higher temperatures, check more often. For severe service vehicles, check at 7,500 miles (12 000 km).

To determine the battery charge, check the battery test indicator on top of the battery. Refer to illustration. When the battery has a yellow or bright indicator, water should be added.

BATTERY CONDITION INDICATOR	O.K. TO JUMP START	 <ul style="list-style-type: none"> DARKENED INDICATOR WITH GREEN DOT <ul style="list-style-type: none"> • BATTERY CHARGE OK • FLUID LEVEL OK DARKENED INDICATOR NO GREEN DOT <ul style="list-style-type: none"> • BATTERY CHARGE LOW • FLUID LEVEL OK
	DO NOT JUMP START	 <ul style="list-style-type: none"> YELLOW OR BRIGHT INDICATOR <ul style="list-style-type: none"> • BATTERY CHARGE UNKNOWN • FLUID LEVEL LOW <p>(CHARGE MAY STILL BE SUFFICIENT TO START YOUR CAR)</p>

8000b02

To add water to the battery, use a wide bladed tool to carefully lift the battery cell caps. Check the fluid level in

each filler well. Add distilled water to maintain the fluid level above the battery plates but no higher than the bottom of the fill well. In freezing weather, add water just before driving to assure mixing with the battery fluid to prevent freezing.

Keep the battery terminals clean and free from corrosion by cleaning them periodically with a solution of baking soda and water.

CAUTION!

Keep battery fluid and any deposits removed from the battery connections away from paint, sheet metal and plastics. Damage to these materials could result.

Battery Warnings

WARN

Handled improperly, battery
Follow these precautions
tory:

Use extreme care when se
fluid contains sulfuric acid
eyes and skin. Safety glass
Protective clothing are recom
eyes or skin, flush immedi
water. Get emergency med

Batteries produce hydroge
serious bodily injury.
 servicing battery. Ke
away from battery filler cap

Battery Warnings

WARNING!

Handled improperly, batteries can be dangerous. Follow these precautions when servicing your battery:

Use extreme care when servicing the battery. Battery fluid contains sulfuric acid and must be kept from the eyes and skin. Safety glasses, rubber gloves and protective clothing are recommended. If acid contacts eyes or skin, flush immediately with large amounts of water. Get emergency medical attention immediately.

Batteries produce hydrogen gas and can explode and cause serious bodily injury. Don't smoke while checking or servicing battery. Keep open flames and sparks away from battery filler caps.

- To avoid a short circuit which could cause injury, never allow tools or metal objects to contact the battery posts and vehicle at the same time. Also, disconnect the negative battery cable when checking or servicing battery.
- Always keep battery fluid away from children and pets.
- Do not store the battery where there is a likelihood of open fire, sparks, or accessibility to children.
- See Jump Starting Procedure and Jump Starting Warnings in this manual for other battery guidelines.

Vehicle Storage

If you are leaving your vehicle dormant for more than 21 days you may want to take steps to protect your battery. You may:

- Remove the mini fuse #16 in the Power Center labeled IOD (Ignition Off-Draw).
- Or, disconnect the negative cable from the battery.

Power Steering Fluid

WARNING!

You could be injured by moving parts if you check the Power Steering Fluid with the engine running. What the engine OFF.

Fluid Level Check

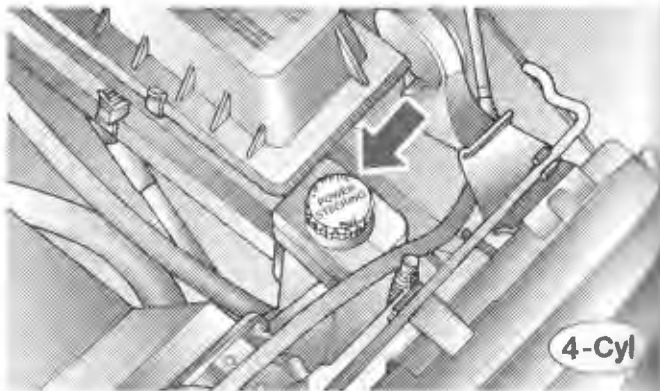

The power steering fluid should be checked at the power steering reservoir by removing the cap dipstick whenever the vehicle is serviced. Before removing the reservoir cap, clean the cap and reservoir. The dipstick should

to FULL COLD when
the engine is at



Fluid
pour into res
pilled fluid fro

Indicate **FULL COLD** when the fluid is cold and **FULL HOT** when the engine is at normal operating temperature.

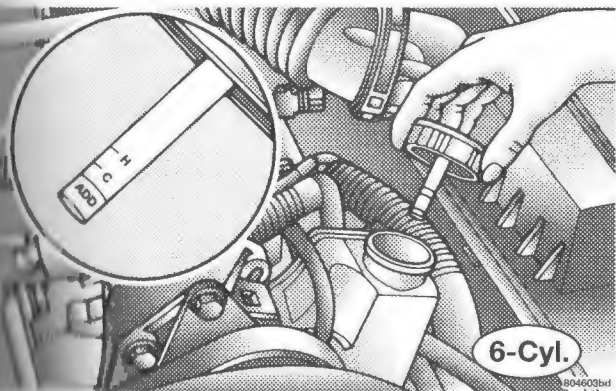

Adding Fluid
 Remove cap and pour into reservoir. Do not overfill.
 Clean spilled fluid from all surfaces.

Recommended Fluid

Use only petroleum fluids specially formulated for minimum effect on rubber hoses. MOPAR Power Steering Fluid is a fluid of this type and is recommended. Do not use automatic transmission fluid.

Windshield Washer Fluid

Fluid Level Check

Look through the plastic washer fluid bottle.

Adding Fluid

Remove cap and pour washer fluid into the bottle.

WARNING!

Commercially available windshield washer solvents are flammable. They could ignite and burn you. Care must be exercised when filling or working around the washer solution.

Recommended Fluid

Mopar All Weather Windshield Washer Solvent or equivalent commercial windshield washer solvent.

Windshield Wipers

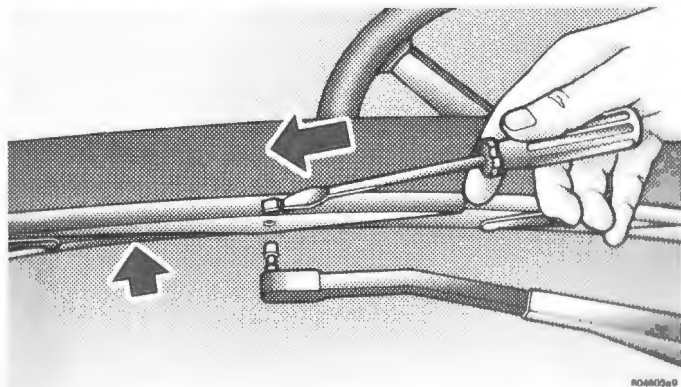

To replace, use a small screwdriver to pull up the retainer spring, then remove the blade assembly from the wiper pin.

Rear Window Wiper

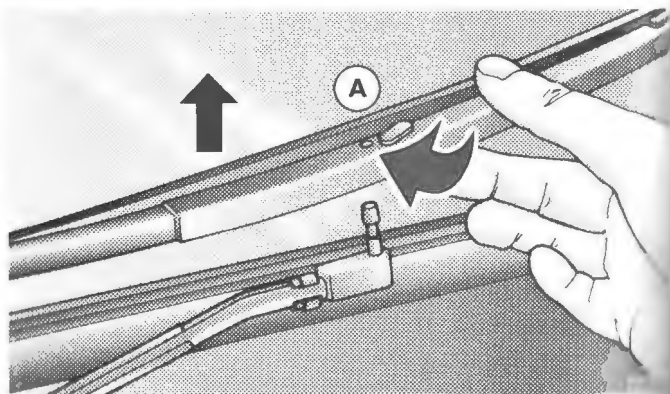

To replace, turn the release lever (A), then pull blade assembly from wiper arm pin.

Brake System

Checking Fluid Level
The Brake Fluid reservoir cleaner.

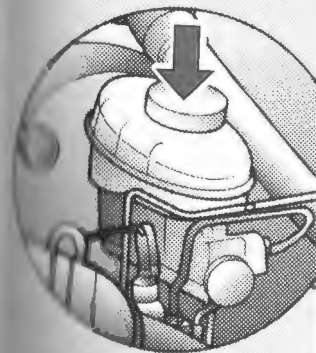

Brake System

Checking Fluid Level

The Brake Fluid reservoir is located behind the air cleaner.

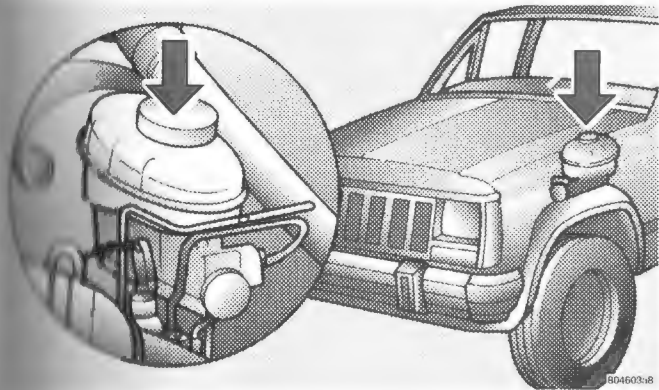

Clean the cap and reservoir exterior before removing the cap. Fill the reservoir to the full mark on the side of the reservoir. Do not overfill.

WARNING!

Do not overfill. The fill level is marked on the side of the reservoir. Too much fluid will create excessive pressure and leak fluid around cap of reservoir. Your brakes may not work properly and you could have an accident.

Recommended Fluid

Mopar Brake Fluid or equivalent meeting SAE J1703 and DOT 3.

Brake System Tips

WARNING!

Improperly maintained brakes can lead to brake failure and an injury accident. The following tips will help maintain your brakes safely:

- Clean all dirt and grease from the reservoir cover before removing it to check or add fluid. Contamination of brake fluid could cause brake failure, resulting in bodily injury.
- Do not use reclaimed fluid, mineral oil, fluid that was stored in old or open containers, or brake fluid inferior to SAE Standard J1703. Be sure to handle the brake fluid in clean containers that will not introduce even a slight amount of foreign liquids or particles. Such contamination of brake fluid could lead to brake failure.
- Under normal service, brake fluid level should not drop rapidly. If you have to frequently replenish the master cylinder reservoir, immediately obtain corrective service.

Front Brakes

Usually check for worn brake pads through the brake caliper inspection port.

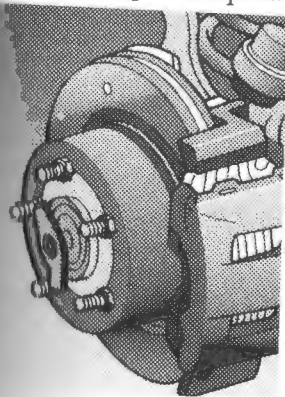

Front Brakes

Regularly check for worn brake pads through each disc brake caliper inspection port.

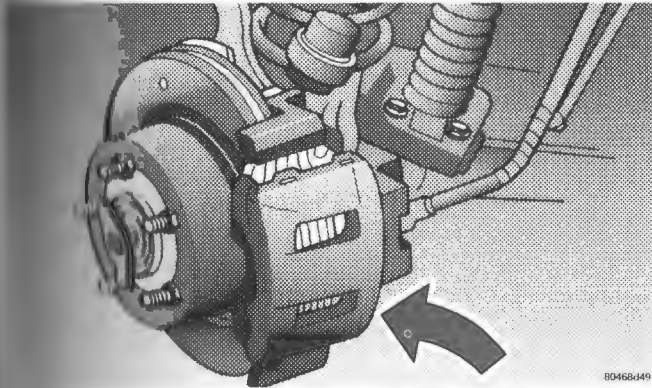

80468-149

Air Conditioning

Air Conditioner Sight Glass

Check for Adequate Refrigerant Level:

1. With the automatic transmission in P (Park) (or a manual transmission in N (Neutral) and the parking brake fully applied, place the air conditioner control at OFF, start the engine and let it run.

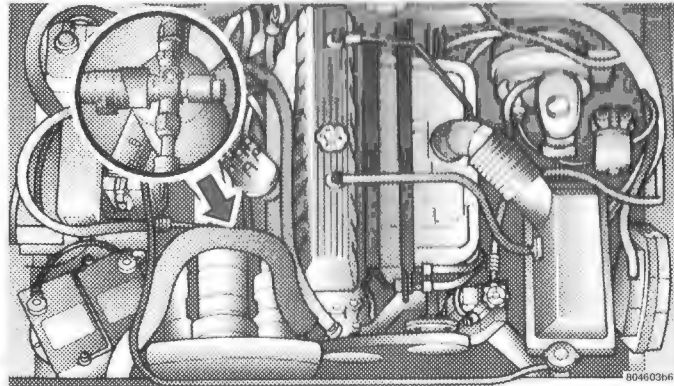

804603b6

2. Clean the sight glass in the engine compartment, switch the air conditioner control to MAX and observe fluid for bubbles.
3. If a short spurt of bubbles appears, then disappears, the system is charged. If bubbles continue to appear, the system is undercharged. See your dealer for service.

Loss of refrigerant may be an indication of leakage in the air conditioning system. Do not add refrigerant without checking the system for leaks.

Air Conditioner Maintenance

For best possible performance, your air conditioner should be checked and serviced by an Authorized Jeep Dealer at the start of each warm season. This service should include cleaning of the condenser fins and a refrigerant level check. Drive belt tension should also be checked at this time.

NOTE: It is unlawful for anyone other than a certified technician to service or add refrigerant to an air conditioning system containing R-134A refrigerant.

WARNING!

Never add air conditioning refrigerant to correct a non-cooling problem unless pressure gauges are connected to the system by a certified technician. Lack of cooling could be due to a restriction and adding refrigerant may cause a dangerous pressure rise and you could be injured.

WARN

Use only refrigerants approved for your air conditioning system. Improperly mixed refrigerants are flammable and may injure you. Other unapproved refrigerants may cause the system to fail, reducing cooling performance.

R-134a Air Conditioning Refrigerant
Have your air conditioner checked at the start of each warm season. The service should include cleaning of the condenser fins and a refrigerant level check. Drive belt tension should also be checked.

Refrigerant Recovery and Recycling
R-134a Air Conditioning Refrigerant (HFC) that is endorsed by the EPA and is an ozone friendly refrigerant. Chrysler Corporation recommends that air conditioning service be performed by a certified technician.

WARNING!

Refrigerants approved by Chrysler Corporation for your air conditioning system. Some unapproved refrigerants are flammable and can explode, injure you. Other unapproved refrigerants can damage your system to fail, requiring costly repairs.

Conditioning Refrigerant

Your air conditioner should be checked at the start of each season. The service should include cleaning of the condenser coils and a refrigerant level check. Drive belt tension should also be checked at this time.

Recovery and Recycling

Conditioning Refrigerant is a hydrofluorocarbon that is endorsed by the Environmental Protection Agency and is an ozone-saving product. However, Chrysler Corporation recommends that air conditioning service be performed by dealers or other

service facilities using recovery and recycling equipment.

Front/Rear Axle Fluid**Checking Fluid Level**

Lubricant should be 1/2" below the oil fill hole.

Adding Fluid

Add lubricant only at the fill hole and only to the level specified above.

Recommended Fluid

Mopar Gear Lubricant or equivalent SAE 75W-90 API-GL5 grade. Models with Class III Hitch Trailer Towing Package use SAE 75W-140 Synthetic Gear Lubricant in the rear axle. Models equipped with Trac-Lok require an additive.

Fluid Capacity

Front — 3.125 U.S. pints/1.5L

Rear — 2.5 U.S. pints/1.2L

Driveline And Steering Component Lubrication

U-joints (cardan joints), prop shafts, yokes, ball joints and other driveline and steering components are provided with grease fittings for lubrication. Lubrication of these components at the intervals specified in the maintenance schedules is very important, particularly if your vehicle is subjected to off-road or other heavy-duty use. See your dealer for complete service information.

Selection of Lubricating Grease



The National Lubricating Grease Institute (NLGI) has developed a symbol (Certification Mark) to aid the vehicle owner in the proper selection of grease for the lubrication of wheel bearings and chassis components. This symbol, an example shown here, is located on the grease

container and identifies the application and quality of the grease.

There are two groups identified, those for wheel bearing (Letter "G") and those for chassis (Letter "L") lubrication. Performance categories within these groups result in dual letter designations for each group. The letter designations shown in the example are the highest quality level available and when combined as shown can be used for both, wheel bearing and chassis lubrication. Use only those greases that have the NLGI symbol on the container along with the proper quality level for your application.

CAUTION

Under frequent heavy use, change all lubricants at intervals, all driveline joints more often than in normal service wear.

Body Lubrication

Lubricate all body pivot points, tracks, doors, liftgate, etc. Lubricated periodically to protect against rust. Clean any lubricant, the body clean to remove dust and grease. Oil and grease should also be given attention to insure proper function. For more information, see the hood services, the hood

CAUTION!

Under frequent heavy duty driving conditions, change all lubricants and lubricate body components, all driveline joints and steering linkage more often than in normal service to prevent excessive wear.

Body Lubrication

Locks and all body pivot points, including such items as seat tracks, doors, liftgate, and hood hinges, should be lubricated periodically to assure quiet, easy operation and to protect against rust and wear. Prior to the application of any lubricant, the parts concerned should be wiped clean to remove dust and grit; after lubricating excess oil and grease should be removed. Particular attention should also be given to hood latching components to insure proper function. When performing other hood services, the hood latch, release mechanism

and safety catch should be cleaned and lubricated.

The external lock cylinders should be lubricated twice a year, preferably in the fall and spring. Apply a small amount of a high quality lubricant such as MOPAR lock cylinder lubricant, P/N 4318084 directly into the lock cylinder.

Appearance Care And Protection From Corrosion**Protection Of Body And Paint From Corrosion**

Vehicle body care requirements vary according to geographic locations and usage. Chemicals that make roads passable in snow and ice, and those that are sprayed on trees and road surfaces during other seasons, are highly corrosive to the metal in your vehicle.

The following maintenance recommendations will enable you to obtain maximum benefit from the corrosion resistance built into your Jeep vehicle.

What Causes Corrosion?

Corrosion is the result of deterioration or removal of paint and protective coatings from your vehicle.

The most common causes are:

- Road salt, dirt and moisture accumulation.
- Stone and gravel impact.
- Insects, tree sap and tar.
- Salt in the air near sea-coast localities.
- Atmospheric fallout/industrial pollutants.

Washing

- Wash your Jeep vehicle regularly. Always wash your vehicle in the shade using a mild car wash soap and rinse the panels completely with clear water.
- If insects, tar or other similar deposits have accumulated on your vehicle, wash it as soon as possible.

- Use Mopar auto polish to remove road film and stains and to polish your vehicle. Take care never to scratch the paint.
- Avoid using abrasive compounds and power buffing that may diminish the gloss or thin out the paint finish.

CAUTION!

Do not use abrasive or strong cleaning material such as steel wool or scouring powder, which will scratch metal and painted surfaces.

Special Care

- If you drive on salted or dusty roads or if you drive near the ocean, hose off the undercarriage at least once a month.

- The drain holes in the lower panels and rear deck lid must be kept clear.
- If you detect any stone chips or scratches, immediately touch them up. You are considered the responsibility of the owner.
- If your Jeep vehicle is damaged by a similar cause which destroys the paint coating, have your vehicle repainted. The cost of such repairs is the responsibility of the owner.
- If you carry special cargo such as motor salt, etc., assure that it is properly packaged and sealed.
- If a lot of driving is done on dirt roads or stone shields behind the wheels.

the drain holes in the lower edges of the doors, rocker panels and rear deck lid must be kept clear and open.

If you detect any stone chips or scratches in the paint, touch them up immediately. The cost of such repairs is considered the responsibility of the owner.

If your Jeep vehicle is damaged due to an accident or similar cause which destroys the paint and protective coating, have your vehicle repaired as soon as possible. The cost of such repairs is considered the responsibility of the owner.

If you carry special cargo such as chemicals, fertilizers, caustic salt, etc., assure that such materials are well packaged and sealed.

If a lot of driving is done on gravel roads, consider mud or stone shields behind each wheel.

- Use Mopar touch-up paint on scratches as soon as possible. Your dealer has touch-up paint to match the color of your vehicle.
- Aluminum wheels should be cleaned regularly with mild soap and water to prevent corrosion. To remove heavy soil, select a non-abrasive, non-acidic cleaner. Do not use scouring pads or metal polishes. Avoid automatic car washes that use acidic solutions or harsh brushes that may damage the wheels' protective finish.

Interior Care

Use Mopar Fabric Cleaner to clean fabric upholstery and carpeting.

Use Mopar Vinyl Cleaner to clean vinyl or leather upholstery.

Mopar Vinyl Cleaner is specifically recommended for interior vinyl trim.

WARNING!

Do not use volatile solvents for cleaning purposes. Many are potentially flammable, and if used in closed areas they may cause respiratory harm. Do not use gasoline, turpentine, kerosene, etc. for cleaning. Use the Mopar recommended products or the equivalents.

Glass Surfaces

All glass surfaces should be cleaned on a regular basis with any commercial household-type glass cleaner. Never use an abrasive type cleaner. Use caution when cleaning inside rear windows equipped with electric defrosters. Do not use scrapers or other sharp instruments which may scratch the elements.

When cleaning the rear view mirror, spray cleaner on the towel or rag that you are using. Do not spray cleaner directly on the mirror.

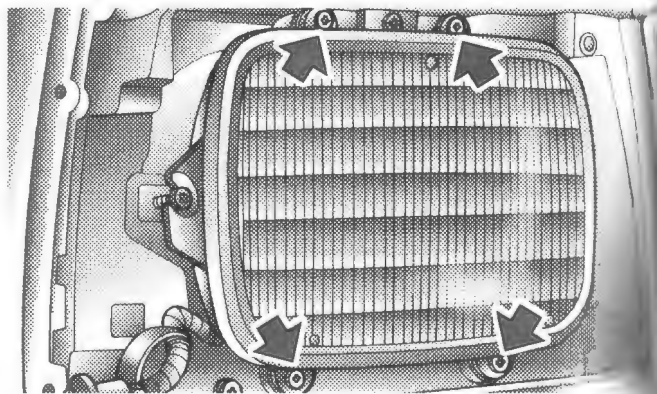
BULB REPLACEMENT**Headlights**

1. Remove screws as shown and take off sidemarker lens.
2. Remove 2 screws holding bezel in place.
3. Remove headlamp bezel and replace lamp.

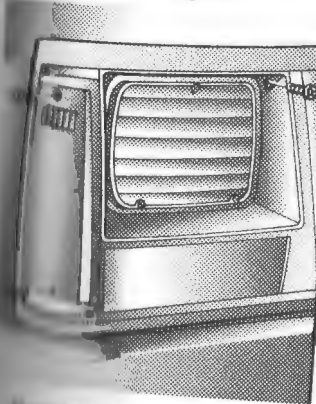
Slide Marker Lights

1. Remove screws from side marker light bezel to change bulb.
2. Remove socket from back of lens and pull out. Reverse procedure to install new bulb.

Side Marker Lights

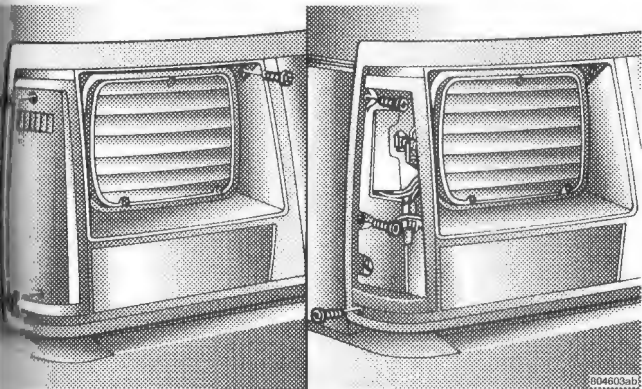

Remove screws from side marker lamp. Remove from light bezel to change bulb.

Twist socket from back of lamp turn counterclockwise and pull out. Reverse procedure to install.

Front Park/Turn Signal Light Replacement

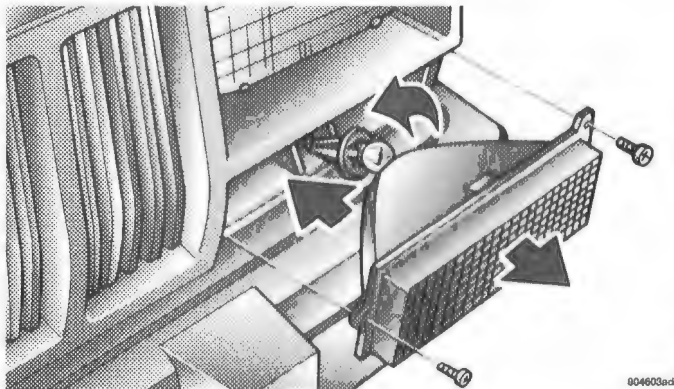

1. Remove screws as shown.
2. Turn bulb assembly 1/3 turn and pull from socket to replace bulb.

Backup, Rear Turn Signal, Side Marker And Taillight Replacement

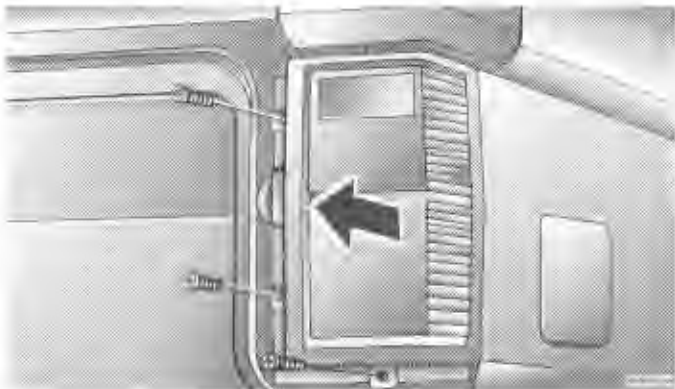

1. There are four mounting bolts attaching the taillamp assembly. When removing, unfasten the three bolts located on the top and side. Do not remove the bottom shoulder bolt; lift up and out to remove the assembly.

2. Turn bulb assembly 1/3 turn and pull from socket to replace bulb.

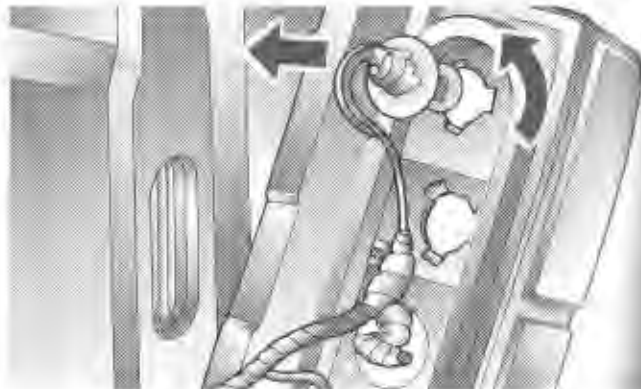

Enter High-Mounted Stop
Open the liftgate, the sto
panel at the base of the

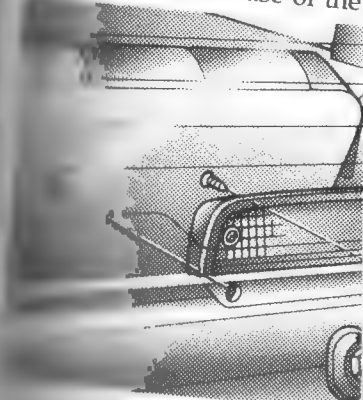

Center High-Mounted Stoplamp

Open the liftgate, the stoplamp is mounted to the body panel at the base of the rear window.

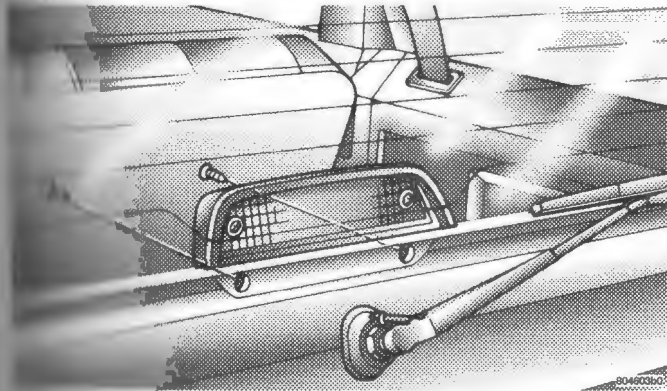

2. Remove the trim plugs to gain access to the lamp housing mounting screws.
3. Remove the screws holding the lamp housing to the body panel.
4. Remove the two screws that secure the lamp.
5. Rotate bulb sockets 1/4 turn and pull from housing.

REPLACEMENT BULBS

Interior Lamps	Bulb Type
Ashtray Lamp	1891
Auto. Trans. Floor Shift Lamp	658
Cargo Lamp	561
Cigarette Lighter Lamp	53
Climate Control Lamp (2)	74
Dome Lamp	561
Dome/Reading Lamp	(1) 561 and (2) 906
Glove Box Lamp	194
Lighted Vanity Mirror (2)*	P/N 6501966
Map Reading Lamp in Overhead Console (4)	912
Rocker Switch Lamp	37
Transfer Case Lamp	658
Underpanel Courtesy Lamps (2)	168

*Available only at Chrysler Dealers.

Exterior Lamps

	Bulb Type
Backup Lamps (2)	11
Center High-Mounted Stoplamp (2)	91
Fog Lamps	11
Front Park/Turn Lamps (2)	2057
Front Side Marker Lamps (2)	194
Headlights (2)	11 (6)
Rear License Plate Lamp	194
(w/Outside Spare)	91
Rear Stop/Tail Lamps (2)	2057
Rear Turn Signal Lamps (2)	11
Underhood Lamp	194

NOTE: Numbers refer to commercial bulb types that can be purchased from your local Jeep dealer.

ELECTRICAL POWER DIS



...vehicle is equipped with
...center located in the en;

ELECTRICAL POWER DISTRIBUTION CENTER

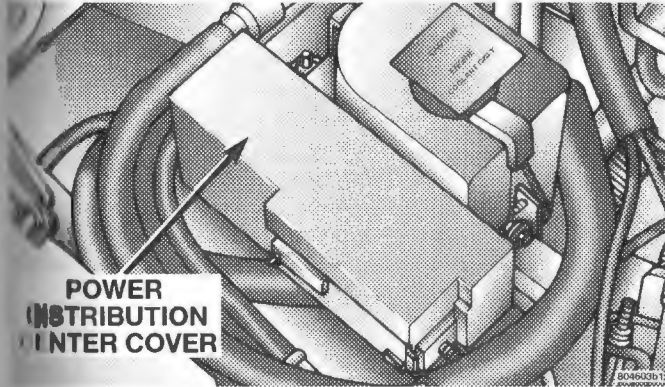

Your vehicle is equipped with an electrical power distribution center located in the engine compartment near the

battery. This power center houses new plug-in "Maxi" fuses which replace all the in-line fusible links previously used. The power center also contains Mini fuses and plug-in ISO relays. A label inside the latching cover of the center identifies each component for ease of replacement, if necessary. "Maxi" fuses and relays can be obtained from your Jeep dealer.

NOTE: If your radio exhibits erratic memory loss, look under the hood in the Power Distribution Center. Be certain that the IOD fuse (#19) is firmly seated.

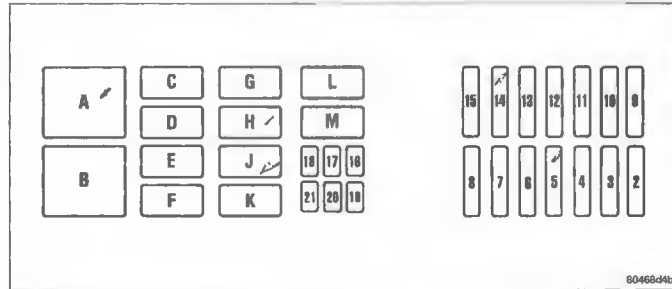

POWER DISTRIBUTION CENTER		
A	RELAY	ABS PUMP
B	OPEN	
C	RELAY	FUEL PUMP
D	OPEN	
E	RELAY	STARTER
F	OPEN	
G	RELAY	AUTO SHUTDOWN
H	RELAY	AUXILIARY FAN
J	RELAY	ABS SYSTEM
K	RELAY	A/C CLUTCH
2	20 AMP YELLOW	STOP LIGHT SWITCH & COMBINATION FLASHER
3	40 AMP ORANGE	FUSE 18 IN FUSE PANEL
4	40 AMP ORANGE	FUSE 11 IN FUSE PANEL, CIRCUIT BREAKER 16 IN FUSE PANEL

POWER DISTRIBUTION CENTER		
5	40 AMP ORANGE	ABS PUMP MOTOR RELAY
6	30 AMP GREEN	POWERTRAIN CONTROL MODULE, TRANSMISSION CONTROL MODULE, FUEL PUMP RELAY
7	OPEN	
8	50 AMP BLUE	IGNITION SWITCH (START)
9	OPEN	
10	30 AMP GREEN	A/C CLUTCH RELAY
11	OPEN	
12	OPEN	
13	40 AMP ORANGE	HEADLIGHT SWITCH, FUSE 4 & 10 IN FUSE PANEL
14	30 AMP GREEN	ABS MAIN RELAY

POWER DISTRIBUTION CENTER	
30 AMP GREEN	RADIATOR FAN RELAY
OPEN	
15 AMP MINI BLUE	DATA LINK CANNOT LIGHT RELAY (FOG LIGHTS)
15 AMP MINI BLUE	A/C COMPRESSOR RELAY, RADIATOR FAN RELAY (ENG.), EVAPORATOR RELAY, LOW WASH/WAX SWITCH, PARKING BRAKE SWITCH, BACKUP LIGHTS (MANUAL TRAILER BRAKE)

POWER DISTRIBUTION CENTER

15	30 AMP GREEN	RADIATOR FAN RELAY (4.0L ENG.)
16	OPEN	
17	15 AMP MINI BLUE	DATA LINK CONNECTOR, PARK LIGHT RELAY & HIGH BEAM RELAY (FOG LIGHTS)
18	15 AMP MINI BLUE	A/C COMPRESSOR CLUTCH RELAY, RADIATOR FAN RELAY (4.0L ENG.), EVAP/PURGE SOLENOID, LOW WASHER FLUID LEVEL SWITCH, PARK NEUTRAL POSITION SWITCH (AUTO. TRANS.), BACKUP LIGHT SWITCH (MANUAL TRANS.)

POWER DISTRIBUTION CENTER

19	20 AMP MINI YELLOW	IGNITION OFF DRAW (FUSE 9 IN FUSE PANEL)
20	30 AMP MINI GREEN	AUTO SHUTDOWN RELAY
21	10 AMP MINI RED	TRANSMISSION CONTROL MODULE (W/4.0L ENG./ AUTO TRANS), TORQUE CONVERTER CLUTCH SOLENOID (IN TRANS-W/2.5L ENG. & AUTO TRANS)

RELAYS

Relays are packaged together and are located behind the lower section of the instrument panel to the right of the steering wheel.

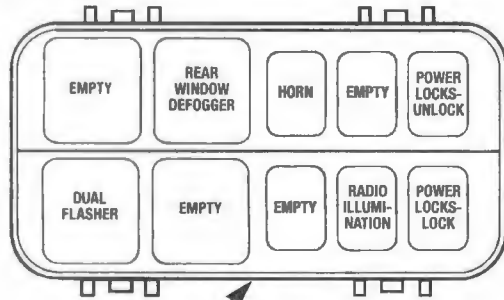

RELAY CENTER

80474b60

FUSE PANEL

The fuse panel is located beneath the instrument panel on the left of the steering wheel.

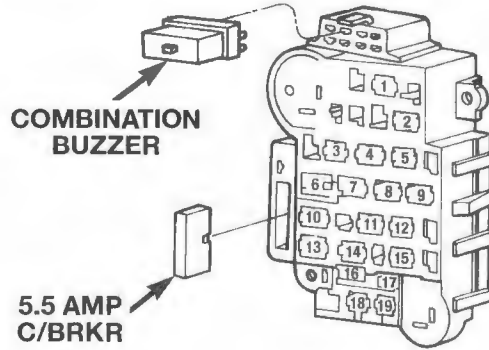

Cavity	Amp/Color	
1	25 Amp Natural	Rear W
2	15 Amp Lt Blue	Radio,
3	Empty	
4	15 Amp Lt Blue	Passing
5	30 Amp Natural	Blower
6	30 Amp C/BRKR	Power
7	2 Amp Pink	Antiloc
8	20 Amp Yellow	Turn Sig

Cavity	Amp/ Color	Items Fused
1	25 Amp Natural	Rear Wiper, Rear Washer
2	15 Amp Lt Blue	Radio, Cigar Lighter
3	Empty	
4	15 Amp Lt Blue	Passing Light
5	30 Amp Natural	Blower Motor
6	30 Amp C/BRKR	Power Windows
7	2 Amp Pink	Antilock Brakes
8	20 Amp Yellow	Turn Signal Flasher

Cavity	Amp/ Color	Items Fused
9	10 Amp Red	Radio/Clock & Memory, Courtesy Lights, Glove Box, Cargo, Dome Lamps, Telltales
10	Empty	
11	25 Amp natural	Headlamp Delay Module, Horns
12	Empty	
13	20 Amp Yellow	Power Door Locks
14	Empty	
15	15 Amp Lt Blue	I.P. Lamps, Clock, Radio/Clock & Memory, Headlamp Switch, Park Lamps
16	30 Amp C/BRKR	Power Seats, Trailer Tow

Cavity	Amp/ Color	Items Fused
17	7.5 Amp Voilet	Instrument Cluster Gauges, Headlamp Delay Module, Chime Module, Overhead Console
18	25 Amp Natural	Heated Rear Window
19	5 Amp Tan	Instrument Panel Lamps, Radio Illumination
20	5.5 Amp C/BRKR	Windshield Wiper/Windshield Washer

Electrical Failure

In case of a minor short circuit, you can change a fuse. Repeated short circuits indicate an electrical problem. If a fuse continues to fail, see your dealer. Do not use a higher amperage fuse than specified.

Vehicles equipped with a Class III trailer towing package contain an additional circuit breaker. The circuit breaker is located near the fuse panel and will protect the wiring for trailer tow load.

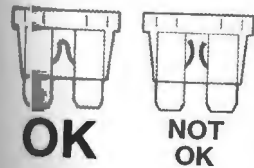

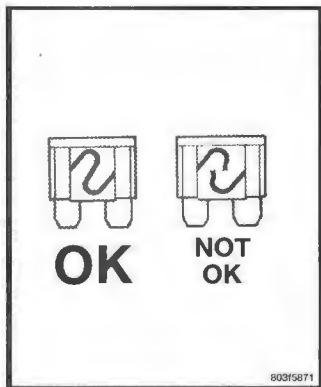
GENERAL SPECIFICATIONS

	Four-Cylinder	Six-Cylinder
Type	In-Line, OHV	In-Line, OHV
Bore And Stroke	98.4mm x 81mm (3.88 in. x 3.19 in.)	98.4mm x 86.9 mm (3.88 in. x 3.41 in.)
Cylinder Block	Cast Iron	Cast Iron
Cylinder Head	Cast Iron	Cast Iron
Displacement	2.5l (150 cubic inches)	4.0l (242 cubic inches)
Compression Ratio	9.2:1	8.8:1
Fuel System	Multi-Point Fuel Injection	Multi-Point Fuel Injection

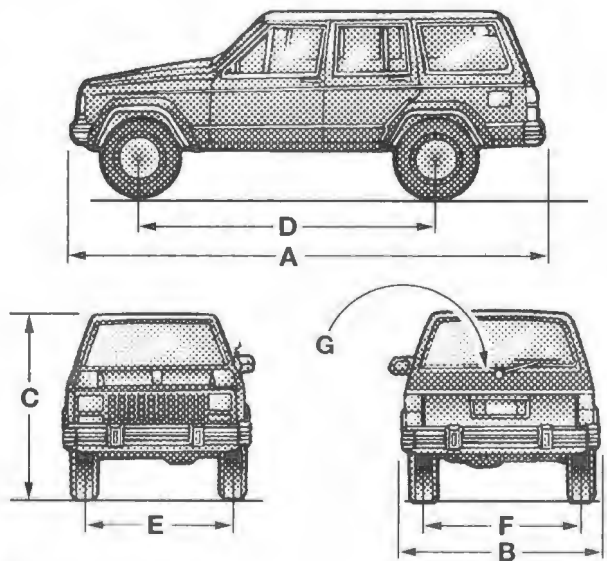

804803b4

Overall Length	A	429.8 cm (169.2 in.)
Overall Width	B	179 cm (70.5 in.)
Overall Height (empty)	C	161 cm (63.3 in.)
Wheelbase	D	257.6 cm. (63.3 in.)
Front Track	E	147.3 cm (58 in.) Cherokee with 7" wheel
Rear Track	F	See E above
Cargo Area Capacity	G	2.0m3 (71.8 ft.3) seat down
Curb Weight (base vehicle):		
4x2		
	2 Door	1274 kg (2808 lbs.)
	4 Door	1293 kg (2850 lbs.)
4x4		
	2 Door	1354 kg (2985 lbs.)
	4 Door	1374 kg (3028 lbs.)

RECOMMENDED FLUIDS

Analysis

Component

Automatic Transmission

Differential (front-rear)

Master Cylinder &
Lock Brake System Reser

Hydraulic Clutch Reservoir

Transmission

Power Steering Pump

Washer Fluid

Steering & Linkage, Ball
Joints, U-Joints, &
Wheel Bearings

RECOMMENDED FLUIDS, LUBRICANTS AND GENUINE PARTS

Chassis

Component	Specification
Automatic Transmission	4.0L Engine: Mopar Automatic Transmission Fluid (P/N 4773590) or equivalent labeled DEXRON® III MERCON® should NOT be used unless the recommended fluid is not available.
Axle Differential (front-rear)	Mopar Gear Lubricant or equivalent of SAE 75W-90 (API-GL5). For trailer towing applications use a SAE 75W-140 Synthetic Gear Lubricant in rear axle. Models equipped with Trac-Lok require an additive.
Brake Master Cylinder & Anti-Lock Brake System Reservoir	Mopar Brake/Clutch Fluid or equivalent marked FMVSS no. 116, DOT-3 and SAE J1703. CAUTION! Use only recommended brake fluids.
Hydraulic Clutch Reservoir	Use only Mopar brake & hydraulic clutch fluid, or equivalent meeting standard FMVSS 116 and DOT-3.
Manual Transmission	Mopar Gear Lubricant or equivalent of SAE 75W-90 (API-GL5) quality.
Power Steering Pump	Mopar Power Steering Fluid.
Transfer Case	Mopar Automatic Transmission Fluid or equivalent labeled DEXRON® III or MERCON®
Windshield Washer Fluid	Mopar Windshield Washer Solvent.
Lubricating Gear & Linkage, Ball Joints, Prop Shafts, U-Joints, & Wheel Bearings	Mopar Multi-Purpose Lubricant or equivalent. (4318063) (labeled NLGI Grade 2 EP, GC-LB)

Engine

Component	Specification
Air Cleaner Filter	PN 53004383
Engine Coolant	Mopar All Season Coolant or equivalent Ethylene Glycol coolant.
Engine Oil	API classification certified for use in gasoline engines or SH Energy Conserving Mopar or equivalent. Refer to oil viscosity chart for correct SAE grade.
Oil Filter	Mopar PN 5281090
Spark Plugs	Refer to the Vehicle Emission Control Information label in the engine compartment.

Body

Component	Specification
Hinges: Door And Hood Liftgate/Tailgate	Mopar Engine Oil Mopar Multi-Purpose Lube (4318062 NLGI Grade 2 EP, GC-LB
Latches: Door, Hood/Safety Catch, Liftgate/Tailgate	Mopar Multi-Purpose Lube NLG Grade 2 Ep, GC-LB
Seat Regulator & Track	Mopar Multi-Purpose Lube NLGI Grade 2 EP, GC-LB
Window System Components	Mopar Spray White Lube (4319066)
Lock Cylinders	Mopar Lock Cylinder Lube (4318084)
Parking Brake Mechanism	Mopar Wheel Brg. Grease (4318064) NLGI Grade 1, GC-LBB

CONTENTS

Transmission Control System Maintenance
Dealer Service
Maintenance Schedules

MAINTENANCE SCHEDULES

CONTENTS

■ Emission Control System Maintenance208	□ Schedule "A"211
■ Dealer Service208	□ Schedule "B"218
■ Maintenance Schedules208		

MAINTENANCE SCHEDULES 8

EMISSION CONTROL SYSTEM MAINTENANCE

The "Scheduled" maintenance services, listed in **bold type** in Section 8 must be done at the times or mileages specified to assure the continued proper functioning of the emission control system. These, and all other maintenance services included in this manual, should be done to provide best vehicle performance and reliability. More frequent maintenance may be needed for vehicles in severe operating conditions such as dusty areas and very short trip driving.

Inspection and service also should be done any time a malfunction is suspected.

DEALER SERVICE

Your dealer has the qualified service personnel, special tools and equipment to perform all service operations in an expert manner. Service manuals are available which

include detailed service information for your vehicle. Refer to these manuals before attempting any procedure yourself.

NOTE: Intentional tampering with emissions control systems can result in civil penalties being assessed against you.

MAINTENANCE SCHEDULES

There are two maintenance schedules that show proper service for your Cherokee.

First is Schedule "A". It lists all the scheduled maintenance to be performed under "normal" operating conditions.

Second is Schedule "B". It is a schedule for vehicles that are operated under the conditions:

- Frequent short trip driving less than 5 miles (8 km)
- Trailer towing

- Extensive idling
 - More than 50% of your driving at high speeds during hot weather
 - Off road driving
 - Desert operation
- Use the schedule that best describes your driving conditions. Where time and mileage are given, whichever occurs first.

- Extensive idling
- More than 50% of your driving is at sustained high speeds during hot weather, above 90°F (32°C)
- Off road driving
- Desert operation

Use the schedule that best describes your driving conditions.

Where time and mileage are listed, follow the interval that occurs first.

At Each Stop For Fuel

- Check engine oil level, add as required.
- Check windshield washer solvent and add if required.

MILEAGE/ MONTHS	DEALERSHIP NAME/CODE	DATE	REPAIR ORDER #

Once A Month

- Check tire pressure and look for unusual wear or damage.
- Inspect battery and clean and tighten terminals as required. Check electrolyte level and add water as needed.

MILEAGE/ MONTHS	DEALERSHIP NAME/CODE	DATE	REPAIR ORDER #

210 MAINTENANCE SCHEDULES

Check fluid levels of coolant reservoir, power steering, brake master cylinder, and transmission and add as needed.

Check all lights and all other electrical items for correct operation.

At Each Oil Change

- Inspect exhaust system.
- Inspect brake hoses.
- Rotate the tires at each oil change interval shown on schedule "A" (7,500 miles) or every other interval shown on schedule "B" (6,000 miles).
- Check coolant level, hoses, and clamps.
- Lubricate propeller shaft universal joints and splines (if equipped).
- Lubricate suspension ball joints.
- After completion of off-road (4WD) operation, the underside of the vehicle should be thoroughly inspected. Examine threaded fasteners for looseness.

MILEAGE/ MONTHS	DEALERSHIP NAME/CODE	DATE	REPAIR ORDER #

Schedule "A"

7,500 Miles (12 000 km)

- Change engine oil.
- Replace engine oil filter.
- Lubricate steering linkage (4WD).

MILEAGE/ MONTHS	DEALERSHIP NAME/CODE

15,000 Miles (24 000 km)

- Change engine oil.
- Replace engine oil filter.
- Lubricate steering linkage.

MILEAGE/ MONTHS	DEALERSHIP NAME/CODE

Schedule "A"

7,500 Miles (12 000 km) or at 6 months

- Change engine oil.
- Replace engine oil filter.
- Lubricate steering linkage (4x4 only).

MILEAGE/ MONTHS	DEALERSHIP NAME/CODE	DATE	REPAIR ORDER #

15,000 Miles (24 000 km) or at 12 months

- Change engine oil.
- Replace engine oil filter.
- Lubricate steering linkage.

MILEAGE/ MONTHS	DEALERSHIP NAME/CODE	DATE	REPAIR ORDER #

22,500 Miles (36 000 km) or at 18 months

- Change engine oil.
- Replace engine oil filter.
- Lubricate steering linkage (4x4 only).
- Inspect brake linings.

MILEAGE/ MONTHS	DEALERSHIP NAME/CODE	DATE	REPAIR ORDER #

212 MAINTENANCE SCHEDULES

30,000 Miles (48 000 km) or at 24 months

- Change engine oil.
- Replace engine oil filter.
- Replace air cleaner filter.**
- Replace spark plugs.**
- Inspect and adjust drive belts.
- Lubricate steering linkage.
- Drain and refill automatic transmission fluid.
- Drain and refill transfer case fluid.

MILEAGE/ MONTHS	DEALERSHIP NAME/CODE	DATE	REPAIR ORDER #

37,500 Miles (60 000 km) or at 30 months

- Change engine oil.
- Replace engine oil filter.
- Lubricate steering linkage (4x4 only).
- Drain and refill manual transmission fluid.

MILEAGE/ MONTHS	DEALERSHIP NAME/CODE	DATE	REPAIR ORDER #

45,000 Miles (72 000 km) or at 36 months

- Change engine oil.
- Replace engine oil filter.
- Lubricate steering linkage.
- Inspect brake linings.
- Flush and replace engine oil regardless of mileage.

MILEAGE/ MONTHS	DEALERSHIP NAME/CODE

45,000 Miles (72 000 km) or at 36 months

- Change engine oil.
- Replace engine oil filter.
- Lubricate steering linkage.
- Inspect brake linings.
- Flush and replace engine coolant at 36 months, regardless of mileage.

MILEAGE/ MONTHS	DEALERSHIP NAME/CODE	DATE	REPAIR ORDER #

52,500 Miles (84 000 km) or at 42 months

- Change engine oil.
- Replace engine oil filter.
- Lubricate steering linkage (4x4 only).
- Flush and replace engine coolant if not done at 36 months.

MILEAGE/ MONTHS	DEALERSHIP NAME/CODE	DATE	REPAIR ORDER #

60,000 Miles (96 000 km) or at 48 months

- Change engine oil.
- Replace engine oil filter.
- Replace engine air cleaner filter.**
- Replace ignition cables.**
- Replace spark plugs.**
- Inspect and adjust drive belts.
- Replace fuel filter. Federal only.
- Lubricate steering linkage.
- Drain and refill automatic transmission fluid.
- Drain and refill transfer case fluid.

MILEAGE/ MONTHS	DEALERSHIP NAME/CODE	DATE	REPAIR ORDER #

67,500 Miles (108 000 km) or at 54 months

- Change engine oil.
- Replace engine oil filter.
- Lubricate steering linkage (4x4 only).
- Inspect brake linings.

MILEAGE/ MONTHS	DEALERSHIP NAME/CODE	DATE	REPAIR ORDER #

75,000 Miles (120 000 km) or at 60 months

- Change engine oil.
- Replace engine oil filter.**
- Lubricate steering linkage.
- Drain and refill manual transmission fluid.
- Flush and replace engine oil at 70,000 miles (48 000 km) or at 60 months, whichever comes first.

MILEAGE/ MONTHS	DEALERSHIP NAME/CODE

75,000 Miles (120 000 km) or at 60 months

- Change engine oil.
- Replace engine oil filter.
- Lubricate steering linkage.
- Drain and refill manual transmission fluid.
- Flush and replace engine coolant if it has been 30,000 miles (48 000 km) or 24 months since last change.

MILEAGE/ MONTHS	DEALERSHIP NAME/CODE	DATE	REPAIR ORDER #

82,500 Miles (133 000 km) or at 66 months

- Change engine oil.
- Replace engine oil filter.
- Lubricate steering linkage (4x4 only).
- Flush and replace engine coolant if it has been 30,000 miles (48 000 km) or 24 months since last change.

MILEAGE/ MONTHS	DEALERSHIP NAME/CODE	DATE	REPAIR ORDER #

90,000 Miles (144 000 km) or at 72 months

- Change engine oil.
- Replace engine oil filter.
- Replace engine air cleaner filter.**
- Replace spark plugs.**
- Inspect and adjust drive belts.
- Lubricate steering linkage.
- Drain and refill automatic transmission fluid.
- Drain and refill transfer case fluid.
- Inspect brake linings.

MILEAGE/ MONTHS	DEALERSHIP NAME/CODE	DATE	REPAIR ORDER #

97,500 Miles (156 000 km) or at 78 months

- Change engine oil.
- Replace engine oil filter.
- Lubricate steering linkage (4x4 only).

MILEAGE/ MONTHS	DEALERSHIP NAME/CODE	DATE	REPAIR ORDER #

105,000 Miles (168 000 km) or at 84 months

- Change engine oil.
- Replace engine oil filter.
- Lubricate steering linkage.
- Flush and replace engine coolant.
- Change engine oil at 100,000 miles (160 000 km).

MILEAGE/ MONTHS	DEALER NAME/C

105,000 Miles (168 000 km) or at 84 months

- Change engine oil.
- Replace engine oil filter.
- Lubricate steering linkage.
- Flush and replace engine coolant if it has been 30,000 miles (48 000 km) or 24 months since last change.

MILEAGE/ MONTHS	DEALERSHIP NAME/CODE	DATE	REPAIR ORDER #

112,500 Miles (180 000 km) or at 90 months

- Change engine oil.
- Replace engine oil filter.
- Lubricate steering linkage (4x4 only).
- Drain and refill manual transmission fluid.
- Inspect brake linings.
- Flush and replace engine coolant if it has been 30,000 miles (48 000 km) or 24 months since last change.

MILEAGE/ MONTHS	DEALERSHIP NAME/CODE	DATE	REPAIR ORDER #

120,000 Miles (192 000 km) or at 96 months

- Change engine oil.
- Replace engine oil filter.
- Replace engine air cleaner filter.**
- Replace ignition cables.**
- Replace spark plugs.**
- Inspect and adjust drive belts.
- Replace fuel filter. Federal only.
- Lubricate steering linkage.
- Drain and refill automatic transmission fluid.
- Drain and refill transfer case fluid.

MILEAGE/ MONTHS	DEALERSHIP NAME/CODE	DATE	REPAIR ORDER #

Important: Inspection and service should also be performed any time a malfunction is observed or suspected. Retain all receipts.

Schedule "B"

3,000 Miles (5 000 km)

- Change engine oil.
- Replace engine oil filter.
- Lubricate steering linkage (4x4 only).

MILEAGE/ MONTHS	DEALERSHIP NAME/CODE	DATE	REPAIR ORDER #
3100 37			

6,000 Miles (10 000 km)

- Change engine oil.
- Replace engine oil filter.
- Lubricate steering linkage (4x4 only).

MILEAGE/ MONTHS	DEALERSHIP NAME/CODE	DATE	REPAIR ORDER #

9,000 Miles (14 000 km)

- Change engine oil.
- Replace engine oil filter.
- Lubricate steering linkage (4x4 only).

MILEAGE/ MONTHS	DEALERSHIP NAME/CODE

9,000 Miles (14 000 km)

- Change engine oil.
- Replace engine oil filter.
- Lubricate steering linkage (4x4 only).

MILEAGE/ MONTHS	DEALERSHIP NAME/CODE	DATE	REPAIR ORDER #

12,000 Miles (19 000 km)

- Change engine oil.
- Replace engine oil filter.
- Lubricate steering linkage (4x4 only).
- Drain and refill automatic transmission fluid.
- Drain and refill front and rear axles.‡
- Inspect brake linings.

MILEAGE/ MONTHS	DEALERSHIP NAME/CODE	DATE	REPAIR ORDER #

15,000 Miles (24 000 km)

- Change engine oil.
- Replace engine oil filter.
- Inspect engine air cleaner filter, replace as necessary.**
- Lubricate steering linkage.

MILEAGE/ MONTHS	DEALERSHIP NAME/CODE	DATE	REPAIR ORDER #

18,000 Miles (29 000 km)

- Change engine oil.
- Replace engine oil filter.
- Lubricate steering linkage (4x4 only).
- Drain and refill manual transmission fluid.

MILEAGE/ MONTHS	DEALERSHIP NAME/CODE	DATE	REPAIR ORDER #

21,000 Miles (34 000 km)

- Change engine oil.
- Replace engine oil filter.
- Lubricate steering linkage (4x4 only).

MILEAGE/ MONTHS	DEALERSHIP NAME/CODE	DATE	REPAIR ORDER #

24,000 Miles (38 000 km)

- Change engine oil.
- Replace engine oil filter.
- Lubricate steering linkage.
- Drain and refill automatic transmission fluid.
- Drain and refill front suspension.
- Inspect brake linings.

MILEAGE/ MONTHS	DEALERSHIP NAME/CODE

24,000 Miles (38 000 km)

- Change engine oil.
- Replace engine oil filter.
- Lubricate steering linkage (4x4 only).
- Drain and refill automatic transmission fluid.
- Drain and refill front and rear axles.‡
- Inspect brake linings.

MILEAGE/ MONTHS	DEALERSHIP NAME/CODE	DATE	REPAIR ORDER #

27,000 Miles (43 000 km)

- Change engine oil.
- Replace engine oil filter.
- Lubricate steering linkage (4x4 only).

MILEAGE/ MONTHS	DEALERSHIP NAME/CODE	DATE	REPAIR ORDER #

222 MAINTENANCE SCHEDULES

30,000 Miles (48 000 km)

- Change engine oil.
- Replace engine oil filter.
- Replace engine air cleaner filter.**
- Replace spark plugs.**
- Inspect and adjust drive belts.
- Lubricate steering linkage.
- Drain and refill transfer case fluid.

MILEAGE/ MONTHS	DEALERSHIP NAME/CODE	DATE	REPAIR ORDER #

33,000 Miles (53 000 km)

- Change engine oil.
- Replace engine oil filter.
- Lubricate steering linkage (4x4 only).

MILEAGE/ MONTHS	DEALERSHIP NAME/CODE	DATE	REPAIR ORDER #

36,000 Miles (58 000 km)

- Change engine oil.
- Replace engine oil filter.**
- Lubricate steering linkage
- Drain and refill manual trans
- Drain and refill automatic
- Drain and refill front and r
- Inspect brake linings.

MILEAGE/ MONTHS	DEALERSHIP NAME/CODE

36,000 Miles (58 000 km)

- Change engine oil.
- Replace engine oil filter.
- Lubricate steering linkage (4x4 only).
- Drain and refill manual transmission fluid.
- Drain and refill automatic transmission fluid.
- Drain and refill front and rear axles. ‡
- Inspect brake linings.

MILEAGE/ MONTHS	DEALERSHIP NAME/CODE	DATE	REPAIR ORDER #

39,000 Miles (62 000 km)

- Change engine oil.
- Replace engine oil filter.
- Lubricate steering linkage (4x4 only).

MILEAGE/ MONTHS	DEALERSHIP NAME/CODE	DATE	REPAIR ORDER #
40387	JIPPA	11-11-01	

42,000 Miles (67 000 km) *See TORQUES*

- Change engine oil.
- Replace engine oil filter.
- Lubricate steering linkage (4x4 only).

MILEAGE/ MONTHS	DEALERSHIP NAME/CODE	DATE	REPAIR ORDER #

45,000 Miles (72 000 km)

- Change engine oil.
- Replace engine oil filter.
- Inspect engine air cleaner filter, replace as necessary.**
- Lubricate steering linkage.

MILEAGE/ MONTHS	DEALERSHIP NAME/CODE	DATE	REPAIR ORDER #

48,000 Miles (77 000 km)

- Change engine oil.
- Replace engine oil filter.
- Lubricate steering linkage (4x4 only).
- Drain and refill automatic transmission fluid.
- Drain and refill front and rear axles.‡
- Inspect brake linings.

MILEAGE/ MONTHS	DEALERSHIP NAME/CODE	DATE	REPAIR ORDER #

51,000 Miles (82 000 km)

- Change engine oil.
- Replace engine oil filter.
- Lubricate steering linkage.
- Flush and replace engine

MILEAGE/ MONTHS	DEALERSHIP NAME/CODE

54,000 Miles (86 000 km)

- Change engine oil.
- Replace engine oil filter.
- Lubricate steering linkage.
- Drain and refill manual t

MILEAGE/ MONTHS	DEALERSHIP NAME/CODE

51,000 Miles (82 000 km)

- Change engine oil.
- Replace engine oil filter.
- Lubricate steering linkage (4x4 only).
- Flush and replace engine coolant.

MILEAGE/ MONTHS	DEALERSHIP NAME/CODE	DATE	REPAIR ORDER #

57,000 Miles (91 000 km)

- Change engine oil.
- Replace engine oil filter.
- Lubricate steering linkage (4x4 only).

MILEAGE/ MONTHS	DEALERSHIP NAME/CODE	DATE	REPAIR ORDER #

54,000 Miles (86 000 km)

- Change engine oil.
- Replace engine oil filter.
- Lubricate steering linkage (4x4 only).
- Drain and refill manual transmission fluid.

MILEAGE/ MONTHS	DEALERSHIP NAME/CODE	DATE	REPAIR ORDER #

60,000 Miles (96 000 km)

- Change engine oil.
- Replace engine oil filter.
- Replace engine air cleaner filter.**
- Replace ignition cables.**
- Replace spark plugs.**
- Inspect and adjust drive belts.
- Replace fuel filter. Federal only.
- Lubricate steering linkage.
- Drain and refill automatic transmission fluid.
- Drain and refill transfer case fluid.
- Drain and refill front and rear axles.†
- Inspect brake linings.

MILEAGE/ MONTHS	DEALERSHIP NAME/CODE	DATE	REPAIR ORDER #

63,000 Miles (101 000 km)

- Change engine oil.
- Replace engine oil filter.
- Lubricate steering linkage (4x4 only).

MILEAGE/ MONTHS	DEALERSHIP NAME/CODE	DATE	REPAIR ORDER #

66,000 Miles (106 000 km)

- Change engine oil.
- Replace engine oil filter.
- Lubricate steering linkage (4x4 only).

MILEAGE/ MONTHS	DEALERSHIP NAME/CODE	DATE	REPAIR ORDER #

69,000 Miles (110 000 km)

- Change engine oil.
- Replace engine oil filter.
- Lubricate steering linkage.

MILEAGE/ MONTHS	DEALERSHIP NAME/CODE

69,000 Miles (110 000 km)

- Change engine oil.
- Replace engine oil filter.
- Lubricate steering linkage (4x4 only).

MILEAGE/ MONTHS	DEALERSHIP NAME/CODE	DATE	REPAIR ORDER #

72,000 Miles (115 000 km)

- Change engine oil.
- Replace engine oil filter.
- Lubricate steering linkage (4x4 only).
- Drain and refill manual transmission fluid.
- Drain and refill automatic transmission fluid.
- Drain and refill front and rear axles.‡
- Inspect brake linings.

MILEAGE/ MONTHS	DEALERSHIP NAME/CODE	DATE	REPAIR ORDER #

75,000 Miles (120 000 km)

- Change engine oil.
- Replace engine oil filter.
- Inspect engine air cleaner filter, replace as necessary.**
- Lubricate steering linkage.

MILEAGE/ MONTHS	DEALERSHIP NAME/CODE	DATE	REPAIR ORDER #

78,000 Miles (125 000 km)

- Change engine oil.
- Replace engine oil filter.
- Lubricate steering linkage (4x4 only).

MILEAGE/ MONTHS	DEALERSHIP NAME/CODE	DATE	REPAIR ORDER #

81,000 Miles (130 000 km)

- Change engine oil.
- Replace engine oil filter.
- Lubricate steering linkage (4x4 only).
- Flush and replace engine coolant.

MILEAGE/ MONTHS	DEALERSHIP NAME/CODE	DATE	REPAIR ORDER #

84,000 Miles (134 000 km)

- Change engine oil.
- Replace engine oil filter.
- Lubricate steering linkage (4x4 only).
- Drain and refill automatic transmission.
- Drain and refill front and rear brake fluid.
- Inspect brake linings.

MILEAGE/ MONTHS	DEALERSHIP NAME/CODE

84,000 Miles (134 000 km)

- Change engine oil.
- Replace engine oil filter.
- Lubricate steering linkage (4x4 only).
- Drain and refill automatic transmission fluid.
- Drain and refill front and rear axles.†
- Inspect brake linings.

MILEAGE/ MONTHS	DEALERSHIP NAME/CODE	DATE	REPAIR ORDER #

87,000 Miles (139 000 km)

- Change engine oil.
- Replace engine oil filter.
- Lubricate steering linkage (4x4 only).

MILEAGE/ MONTHS	DEALERSHIP NAME/CODE	DATE	REPAIR ORDER #

230 MAINTENANCE SCHEDULES

90,000 Miles (144 000 km)

- Change engine oil.
- Replace engine oil filter.
- Replace engine air cleaner filter.**
- Replace spark plugs.**
- Inspect and adjust drive belts.
- Lubricate steering linkage.
- Drain and refill manual transmission fluid.
- Drain and refill transfer case fluid.

MILEAGE/ MONTHS	DEALERSHIP NAME/CODE	DATE	REPAIR ORDER #

93,000 Miles (149 000 km)

- Change engine oil.
- Replace engine oil filter.
- Lubricate steering linkage (4x4 only).

MILEAGE/ MONTHS	DEALERSHIP NAME/CODE	DATE	REPAIR ORDER #

96,000 Miles (154 000 km)

- Change engine oil.
- Replace engine oil filter.
- Lubricate steering linkage.
- Drain and refill automatic transmission fluid.
- Drain and refill front axle differential fluid.
- Inspect brake linings.

MILEAGE/ MONTHS	DEALERSHIP NAME/CODE

96,000 Miles (154 000 km)

- Change engine oil.
- Replace engine oil filter.
- Lubricate steering linkage (4x4 only).
- Drain and refill automatic transmission fluid.
- Drain and refill front and rear axles.‡
- Inspect brake linings.

MILEAGE/ MONTHS	DEALERSHIP NAME/CODE	DATE	REPAIR ORDER #

99,000 Miles (158 000 km)

- Change engine oil.
- Replace engine oil filter.
- Lubricate steering linkage (4x4 only).

MILEAGE/ MONTHS	DEALERSHIP NAME/CODE	DATE	REPAIR ORDER #

102,000 Miles (163 000 km)

- Change engine oil.
- Replace engine oil filter.
- Lubricate steering linkage (4x4 only).

MILEAGE/ MONTHS	DEALERSHIP NAME/CODE	DATE	REPAIR ORDER #

105,000 Miles (168 000 km)

- Change engine oil.
- Replace engine oil filter.
- Inspect engine air cleaner filter, replace as necessary.**
- Lubricate steering linkage.

MILEAGE/ MONTHS	DEALERSHIP NAME/CODE	DATE	REPAIR ORDER #

108,000 Miles (173 000 km)

- Change engine oil.
- Replace engine oil filter.
- Lubricate steering linkage (4x4 only).
- Drain and refill manual transmission fluid.
- Drain and refill automatic transmission fluid.
- Drain and refill front and rear axles.
- Inspect brake linings.

MILEAGE/ MONTHS	DEALERSHIP NAME/CODE	DATE	REPAIR ORDER #

111,000 Miles (178 000 km)

- Change engine oil.
- Replace engine oil filter.
- Lubricate steering linkage.
- Flush and replace engine oil.

MILEAGE/ MONTHS	DEALERSHIP NAME/CODE

111,000 Miles (178 000 km)

- Change engine oil.
- Replace engine oil filter.
- Lubricate steering linkage (4x4 only).
- Flush and replace engine coolant.

MILEAGE/ MONTHS	DEALERSHIP NAME/CODE	DATE	REPAIR ORDER #

114,000 Miles (182 000 km)

- Change engine oil.
- Replace engine oil filter.
- Lubricate steering linkage (4x4 only).

MILEAGE/ MONTHS	DEALERSHIP NAME/CODE	DATE	REPAIR ORDER #

117,000 Miles (187 000 km)

- Change engine oil.
- Replace engine oil filter.
- Lubricate steering linkage (4x4 only).

MILEAGE/ MONTHS	DEALERSHIP NAME/CODE	DATE	REPAIR ORDER #

120,000 Miles (192 000 km)

- Change engine oil.
- Replace engine oil filter.
- Replace engine air cleaner filter.**
- Replace ignition cables.**
- Replace spark plugs.**
- Inspect and adjust drive belts.
- Replace fuel filter. Federal only.
- Lubricate steering linkage.
- Drain and refill automatic transmission fluid.
- Drain and refill transfer case fluid.
- Drain and refill front and rear axles.‡
- Inspect brake linings.

MILEAGE/ MONTHS	DEALERSHIP NAME/CODE	DATE	REPAIR ORDER #

(Off-highway operation, trailer use, snow plowing, or other type of prolonged operation with heavy weather, require front and rear axle inspection with a ‡ in Schedule "B". Perform regularly and properly operate your vehicle under these conditions.)

Important: Inspection and service should be performed any time a malfunction is detected. Retain all receipts.

(C) If highway operation, trailer towing, taxi, limousine, snow plowing, or other types of commercial service or prolonged operation with heavy loading, especially in hot weather, require front and rear axle service indicated with a † in Schedule "B". Perform these services if you usually operate your vehicle under these conditions.

Important: Inspection and service should also be performed any time a malfunction is observed or suspected. Retain all receipts.

IF YOU

CONTENTS

- Suggestions For Obtaining Se
Vehicle
- Prepare For The Appointment
- Prepare A List
- Be Reasonable With Request
- If You Need Assistance
- Customer Arbitration Board. . .

IF YOU NEED CUSTOMER ASSISTANCE

CONTENTS

■ Suggestions For Obtaining Service For Your Vehicle238
□ Prepare For The Appointment238
□ Prepare A List238
□ Be Reasonable With Requests238
■ If You Need Assistance238
■ Customer Arbitration Board.240

■ Warranty Information241
■ Mopar Parts241
■ Reporting Safety Defects241
□ In Canada241
■ Publication Order Forms243

SUGGESTIONS FOR OBTAINING SERVICE FOR YOUR VEHICLE

Prepare For The Appointment...

If you're having warranty work done, be sure to have the right papers with you. Take your warranty folder. All work to be performed may not be covered by the warranty, discuss additional charges with the service manager. Keep a maintenance log of your vehicle's service history. This can often provide a clue to the current problem.

Prepare A List...

Make a written list of your vehicle's problems or the specific work you want done. If you've had an accident, or work done that is not on your maintenance log, let the service advisor know. Don't keep secrets.

Be Reasonable With Requests...

If you list a number of items, and you must have your vehicle by the end of the day, discuss the situation with

the service advisor and list the items in order of priority. At many dealers you may obtain a rental vehicle at a minimal daily charge. If you need a rental, it is advisable to make these arrangements when you call for an appointment.

IF YOU NEED ASSISTANCE.....

Chrysler Corporation and its dealers are vitally interested in your satisfaction. We want you to be happy with our products and services.

Your selling dealer is best equipped and most anxious to provide prompt resolution for any warranty issue or related matter that you may experience. Chrysler dealers have the facilities, factory-trained technicians, special tools, and the latest information to assure your vehicle is fixed correctly and in a timely manner. Chrysler Corporation has empowered its dealers to make warranty repair decisions that ensure you are not inconvenienced. There is no need for you to wait for a decision from the

Corporation. If a special circumstance arises, contact the nearest Chrysler office for information from Chrysler, or contact your service manager to make

this is why you should always contact your service manager first. Most matters are handled through the normal process.

If for some reason you are unable to contact your general manager or owner, you may want to know if you need a

If your dealership is unable to resolve your problem, you may contact the Chrysler Corporation.

Your communication to the Corporation should include the following information:

• Owner's name and address

• Owner's telephone number

• Dealership name

poration. If a special circumstance occurs that requires information from Chrysler, we have asked the dealer's service manager to make the contact on your behalf.

is is why you should always talk to your dealer's service manager first. Most matters can be resolved with process.

If for some reason you are still not satisfied, talk to the general manager or owner of the dealership. They want to know if you need assistance.

If your dealership is unable to resolve the concern, you may contact the Chrysler Customer Center.

By communication to the Chrysler Customer Center should include the following information:

Owner's name and address

Owner's telephone number (home and office)

Dealership name

- Vehicle identification number
- Vehicle delivery date and mileage

Chrysler Customer Center

P.O. Box 21-8004
 Auburn Hills, MI 48321-8004
 Phone: (800) 992-1997

Chrysler Canada Customer Service

Chrysler Center
 P.O. Box 1621
 Windsor, Ontario N9A 4H6
 Phone (800) 465-2001
 Ligne bilingue (800) 387-9983

Chrysler De Mexico

Lago Alberto #320
 Mexico 11320, D. F.
 In Mexico (915) 729-1248 or 729-1240
 Outside Mexico (525) 729-1248 or 729-1240

Customer Assistance For The Hearing Or Speech Impaired (TDD/TTY)

To assist customers who have hearing difficulties, Chrysler has installed special TDD (Telecommunication Devices for the Deaf) equipment at its Customer Center. Any hearing or speech impaired customer who has access to a TDD or a conventional teletypewriter (TTY) in the United States can communicate with Chrysler by dialing 1-800-380-CHRY.

Service Contract

You may have purchased additional coverage with an Extended Service Contract. The national number Chrysler Service Contract Center is 1-800-521-9922 (in Canada, contact your selling dealer). If the dealer sold their own service contract, you must refer to the contract documents, find the Program Administrator and contact him for problem resolution.

We appreciate that you have made a major investment when you purchased your new vehicle. Your dealer has also made a major investment in facilities, tools, and training to assure that you are absolutely delighted with your ownership experience. You'll be pleased with the sincere efforts to resolve any warranty issues or related concerns.

CUSTOMER ARBITRATION BOARD

In the 50 United States, and Washington, D.C., if a warranty dispute has not been resolved to your satisfaction, you may submit the issue to a Chrysler Customer Arbitration Board.

Additional information and the address of each Customer Arbitration Board is contained in the Customer Arbitration Board Brochure included in the Glove Box Kit.

WARRANTY INFORMATION
See your Chrysler Warranty information on warranty coverage.

MOPAR PARTS

Mopar fluids, lubricants, parts available from your dealer. They help your vehicle operating at its best.

REPORTING SAFETY DEFECTS

In the 50 United States and Washington, D.C., if you believe that your vehicle has a safety defect that may cause injury or death, you should report it to the National Highway Traffic Safety Administration (NHTSA) in addition to your dealer.

NHTSA receives similar reports and if it finds the

WARRANTY INFORMATION

See your Chrysler Warranty Information Booklet for information on warranty coverage and transfer of warranty.

MOOPAR PARTS

Moopar fluids, lubricants, parts, and accessories are available from your dealer. They will help you keep your vehicle operating at its best.

REPORTING SAFETY DEFECTS

In the 50 United States and Washington D.C.: If you believe that your vehicle has a defect which could cause a crash or cause injury or death, you should immediately inform the National Highway Traffic Safety Administration (NHTSA) in addition to notifying Chrysler Corporation.

If NHTSA receives similar complaints, it may open an investigation, and if it finds that a safety defect exists in

a group of vehicles, it may order a recall and remedy campaign. However, NHTSA cannot become involved in individual problems between you, your dealer, and Chrysler Corporation.

To contact NHTSA, you may either call the Auto Safety Hotline toll free at 1-800-424-9393 (or 366-0123 in Washington DC area) or write to: NHTSA, U.S. Dept. of Transportation, Washington DC 20590. You can also obtain other information about motor vehicle safety from the Hotline.

In Canada:

If you believe that your vehicle has a safety defect, you should contact the Customer Service Department immediately. Canadian customers who wish to report a safety defect to the Canadian government should write to Transport Canada, P.O. Box 8880, Ottawa Postal Station, Ottawa, Ontario K1G 3J2.

PUBLICATION ORDER FORM

U.S. RESIDENTS ONLY — To order (specify year, make, and model, or print), and mail to:

CHRYSLER CORPORATION
c/o Dymet Distribution Service
P.O. Box 360450
Cincinnati, OH 44136

Service Manual Set \$90.00
Specify year, make, and model.
Example: 1995 Dodge Caravan

You also may use this form to order manuals for a previous model year (manuals for previous year period are usually available).

Owner's Manuals \$6.00
Specify year, make, and model.
Example: 1995 Dodge Caravan

CHILD SEAT INSTRUCTIONS (IF APPLICABLE)

Shipping and Handling: Purchase up to \$40.00. Purchases over \$40.00 add 10%.

PUBLICATION ORDER FORMS

U.S. RESIDENTS ONLY — To order a Service Manual Set; tear out this page, fill in all information (please type or print), and mail to:

CHRYSLER CORPORATION
c/o Dyment Distribution Service
P.O. Box 360450
Cincinnati, OH 44136

By Telephone:
1-800-890-4038

Only Visa or Mastercard credit cards are accepted. Please have your order information available at time of call.

U.S. ONLY

- Service Manual Set \$90.00
Specify year, make, and model.
(example: 1995 Dodge Caravan)

You also may use this form to order Owner's Manuals for a previous model year (manuals for the previous 10 year period are usually available).

- Owner's Manuals \$6.00
Specify year, make, and model.
(example: 1995 Dodge Caravan)

- CHILD SEAT INSTRUCTIONS (IF APPLICABLE)

Shipping and Handling: Purchase up to \$40.00 add \$4.00. Purchases over \$40.00 add 10% of the total order.

Name	
Address	
City	
State	Zip
Date	
Amount of check or money order \$ _____	

Enclose check or money order payable to: Chrysler Corporation.

CANADIAN RESIDENTS ONLY — To order a Service Manual Set; tear out this page, fill in all information (please type or print), and mail to:

CHRYSLER CANADA LTD.
c/o Dymont Distribution Services
36 Overlea Blvd.
Toronto, Ontario M4H 1B7

By Telephone:
(416) 421-2920
Only Visa or Mastercard credit cards
are accepted. Please have your order
information available at time of call.

**CANADA
ONLY**

- Service Manual Set \$90.00 + TAX
Specify year, make, and model.
(example: 1995 Dodge Caravan)

You also may use this form to order Owner's Manuals
for a previous model year (manuals for the previous 10
year period are usually available).

- Owner's Manuals \$6.00 + TAX
Specify year, make, and model.
(example: 1995 Dodge Caravan)

- CHILD SEAT INSTRUCTIONS (IF APPLICABLE)

Name	
Address	
City	
Province	Postal Code
Date	
Amount of cheque or money order \$ _____	

Enclose cheque or money order
payable to: Chrysler Canada.

INDEX

Accident Damage	191
Adding Engine Coolant (Antifreeze)	167
Air Cleaner, Engine	170
Air Conditioner Maintenance	185,186
Air Conditioning Sight Glass	185
Air Conditioning System	90
Air Filter	170
Air Pressure, Tires	113
Airbag	23
Alignment and Balance	117
Antifreeze (Engine Coolant)	166
Anti-Lock Brake System	118
Anti-Lock Warning Light	74,79
Appearance Care	189
Ashtray	61
Audio Systems	80
Automatic Transmission	100,173
Adding Fluid	175
Fluid and Filter Changes	173

Fluid Level Check	173
Fluid Type	173
Gear Ranges	103
Shifting	103
Torque Converter	103
Axle Fluid	183
Back-up Lights	193
Battery	173
Charging	143
Emergency Starting	143
Gas Caution	143
Storing Vehicle	143
Voltmeter	143
Belts, Seat	143
Body Mechanism Lubrication	143
Brake System	143
Anti-Lock	143
Disc Brakes	143

Fluid Check	173
Master Cylinder	173
Parking	103
Trailer Towing	103
Warning Light	103
Break-in Recommendations, New	143
Bulb Replacement	143
Bulbs, Light	143
Calibration, Compass	143
Camper	143
Caps, Filler	143
Fuel	143
Oil (Engine)	143
Power Steering	143
Tire Washes	143
Carbon Monoxide Warning	143
Luggage Compartment	143
Capacity	143

- | | | | |
|--|--------|--|-------|
| Fluid Check | 183 | Cargo Light | 50 |
| Master Cylinder | 183 | Cargo Tie-Downs | 66 |
| Marking | 96 | Carpeting | 191 |
| Trailer Towing | 130 | Cassette Tape And Player Maintenance | 86 |
| Warning Light | 73,77 | Cassette Tape Player | 83 |
| Take-in Recommendations, New Vehicle | 28 | Catalytic Converter | 126 |
| Light Replacement | 192 | Center High-Mounted Stoplamp | 195 |
| Light, Light | 196 | Center Lap Belts | 18 |
| Compass | 59 | Chains, Tire | 118 |
| Amper | 127 | Charging | 148 |
| Oil, Filler | | Check Engine Light | 73,78 |
| Fuel | 125 | Checking Your Vehicle For Safety | 29 |
| Oil (Engine) | 163 | Child Restraint | 20 |
| Power Steering | 180 | Child Safety Locks | 12 |
| Washes | 190 | Child Seats | 20 |
| Carbon Monoxide Warning | 29,124 | Cigar Lighter | 61 |
| Compartment | 66 | Climate Control | 87 |
| Capacity | 67 | Clock | 81,84 |
| | | Command-Trac Operation | 106 |

- | | | | |
|-----------------------------------|---------|--------------------------------|---------|
| Compact Spare Tire | 145 | Daytime Running Lights | 49 |
| Compass | 59 | Dealer Service | 208,238 |
| Compass Calibration | 59 | Defogger, Rear Window | 54 |
| Compass Variance | 60 | Defogging and Defrosting | 80 |
| Console, Overhead | 58 | Defroster, Rear Window | 54 |
| Converter, Catalytic | 126 | Defroster, Windshield | 30,80 |
| Cooling System | 140,165 | Delay Wipers | 92 |
| Adding Coolant (Antifreeze) | 167 | Diagrams, Engine | 100 |
| Coolant Capacity | 167 | Dimensions | 20 |
| Coolant Level | 165 | Dimmer Switch, Headlight | 40 |
| Drain, Flush, and Refill | 167 | Dipsticks | |
| Inspection | 165 | Automatic Transmission | 172 |
| Selection of Coolant | 166 | Power Steering | 180 |
| Temperature Gauge | 75 | Disabled Vehicle, Towing | 191 |
| Cruise Control | 55 | Disc Brakes | 160 |
| Cup Holder | 61 | Disposal of | |
| Customer Arbitration Board | 240 | Used Coolant | 160 |
| Customer Assistance | 238 | Used Engine Fluids | 180 |
| | | Door Locks | 100 |

- Driving
- Off-Pavement
- On Hills
- On Slippery Surfaces
- Electric Powered
- Door Locks
- Mirror
- Seats
- Windows
- Electronic Power Distribution C
- Electronic Speed Control
- Emergency, in Case of
- Brake Warning Light
- Coolant Temperature Gauge
- Engine Oil Pressure Gauge
- Moving Vehicle When Stuck
- Hazard Warning Flasher
- Towing

Driving		
Off-Pavement	109	
On Hills	110	
On Slippery Surfaces	110	
Electric Powered		
Door Locks	13	
Mirror	46	
Seats	41	
Windows	38	
Electronic Power Distribution Center	197	
Electronic Speed Control	55	
Emergency, in Case of		
Brake Warning Light	73,77	
Coolant Temperature Gauge	75	
Engine Oil Pressure Gauge	76	
Freeing Vehicle When Stuck	99	
Hazard Warning Flasher	139	
Jacking	141,145	
Jump Starting	148	
Overheating	140	
Tow Hooks	150	
Towing	151	
Emission Control System Maintenance	208	
Engine	157	
Engine Block Heater	95	
Engine		
Air Cleaner	170	
Block Heater	95	
Break-in Recommendations	28	
Compartment	157	
Coolant	166	
Cooling	165	
Exhaust Gas Caution	29,124	
Fails to Start	94	
Flooded, Starting	94	
Fuel Requirements	121	
Jump Starting	148	

Oil	160	Finish Damage	191
Oil Filter	164	Flashers	
Oil Pressure Gauge	76	Hazard Warning	199
Overheating	140	Turn Signal	51,75,193,194
Specifications	203	Flooded Engine Starting	94
Starting	94	Fluid Level Checks	19
Temperature Gauge	75	Automatic Transmission	17
Ethanol	122	Brake	10
Ethylene Glycol Antifreeze	166	Cooling System	10
Exhaust Gas Caution	29,124	Engine Oil	10
Exhaust System	29	Manual Transmission	17
Exterior Finish Care	189	Power Steering	18
Exterior Lighting	47	Transfer Case	17
Fabric Care	191	Fog Lamps	9
Filters		Folding Rear Seat	9
Air Cleaner	170	Four Wheel Drive	10
Engine Oil	164	Operation	10
Finish Care	189	Shifting	10
		Systems	10

Four-way Hazard Flasher	
Freeing A Stuck Vehicle	
Front Axle	
Fuel	
Fuel Specifications	
Fuel	
Methanol	
Filler Cap	
Filler Door	
Gasoline	
Gauge	
Methanol	
Octane Rating	
Requirements	
Tank Capacity	
Trunk	
Trunk Door Opener Storage	
Trunk Cap	

- Four-way Hazard Flasher 139
 Freeing A Stuck Vehicle 99
 Front Axle 187
 Fuel 121
 Fuel Specifications 121
 Fuel
 Ethanol 122
 Filler Cap 125
 Filler Door 125
 Gasoline 121
 Gauge 75,76
 Methanol 122
 Octane Rating 121
 Requirements 121
 Tank Capacity 125
 Fuse 200
 Garage Door Opener Storage 59
 Gas Cap 125
 Gasoline 121
 Gasoline, Reformulated 122
 Gauges
 Coolant Temperature 75
 Fuel 75,76
 Odometer 75
 Oil Pressure 76
 Speedometer 75
 Tachometer 76
 Voltmeter 76
 General Specifications 203
 Glass Cleaning 192
 Glove Compartment 61
 Hazard Warning Flasher 139
 Head Rests 40
 Headlights 47
 High Beam 48,75
 Lights On Reminder 48

Passing	48
Replacing	192
Switch	47
Heater	87
Heater, Engine Block	95
Hitches	
Trailer Towing	130
Hood Release	62
Hydraulic Clutch Fluid	171
If You Need Assistance	238
Ignition	9,93
Key	9
Lock	9,93
Infant Restraint	20
Inflation Pressure Tires	113
Inside Rearview Mirror	44
Instrument Cluster	71,72,73,77
Instrument Panel and Controls	70

Interior Appearance Care	191
Interior Lighting	47,80
Intermittent Wipers	52
Jack Location	141
Jack Operation	141
Jump Starting	141
Key-in Reminder	109
Keyless Entry System	9
Keys	9
Knee Bolster	9
Lamp Replacement	191
Lane Change and Turn Signals	51,75,191
Lap and Shoulder Belts	20
Lap Belts	20
Lead Free Gasoline	191
Lights	191

Anti-Lock Warning
Back-up
Brake Warning
Bulb Replacement
Cargo
Center Mounted Stop
Check Engine
Daytime Running
Dimmer Switch, Headlight
Dome
Engine Coolant Warning
Exterior
Fog
Four Wheel Drive Indicator
Fuses
Generator
Hazard Warning Flasher
Headlight Switch
Headlights

- A**nti-Lock Warning 74,79
Back-up 194
Brake Warning 73,77
Bulb Replacement 192
Cargo 50
Center Mounted Stop 195
Check Engine 73,78
Daytime Running 49
Hammer Switch, Headlight 48
Dome 50
Engine Coolant Warning 74
Interior 47
Log 49
Fur-Wheel Drive Indicator 73,78
Fuses 200
Generator 75
Hazard Warning Flasher 139
Headlight Switch 47
Headlights 47,192
High Beam 48
High Beam Indicator 75
Instrument Cluster 47,71,72,73,77
Intensity Control 47
Interior 50
Lights On Reminder 48
Low Fuel 77
Low Windshield Washer Fluid Warning 74
Oil Pressure 75
Parking 47
Reading 50
Seat Belt Reminder 14,73,78
Side Marker 193,194
Turn Signal 51,75,193,194
Upshift Indicator 74,79,99
Vanity Mirror 46
Washer Fluid 74,79
Lock
Steering Wheel 9

Locks	
Child Protection	12
Door	11
Keys	9,10
Liftgate, Tailgate	10
Power Door	13
Lubricating Oil	188
Lubrication, Body	189
Lug Nuts	146
Luggage Carrier	64
Maintenance Procedures	158
Maintenance Schedule	208
Schedule "A"	211
Schedule "B"	218
Manual, Service	243
Manual Transmission	98,172
Draining	172
Fluid Level Check	172

Lubricant Selection	1
Shift Speeds	193,1
Marker Lights, Side	193,1
Methanol	1
Mirrors	
Outside	
Rearview	
Vanity	
Mopar Parts	
MTBE/ETBE	
Multifunction Control Lever	
New Vehicle Break-in Period	
Occupant Restraints	
Octane Rating, Gasoline	
Odometer	
Trip	
Off-Pavement Driving	

Oil, Engine	
Capacity	
Change Interval	
Dipstick	
Filter	
Identification Logo	
Materials Added to	
Pressure Gauge	
Pressure Warning Light	
Recommendation	
Viscosity	
Oil Filter	
Change	
Selection	
Oil Pressure Light	
Onboard Diagnostic System	
Outside Rearview Mirrors	
Overhead Console	
Overheating, Engine	

Oil, Engine	160	Owner Manuals	243
Capacity	162	Paint Care	189
Change Interval	161	Paint Damage	191
Dipstick	162	Parking Brake	96
Filter	164	Parking On Hill	96
Identification Logo	160	Passing Light	48
Materials Added to	161	Polishing and Waxing	190
Pressure Gauge	76	Power	
Pressure Warning Light	75	Distribution Center	197
Recommendation	160	Door Locks	13
Viscosity	160	Mirrors	46
Oil Filter		Seats	41
Change	164	Steering	180
Selection	206	Windows	38
Oil Pressure Light	75	Pregnant Women and Seat Belts	19
Onboard Diagnostic System	158	Pressure Gauge, Oil	76
Outside Rearview Mirrors	45	Radio	80,83
Overhead Console	58		
Overheating, Engine	140		

Radio Operation	80,83
Rear Axle	187
Rear Shoulder Belts	14
Rear Window Defroster	54
Rear Window Features	54
Rear Wiper/Washer	54,182
Rearview Mirrors	44,45
Reclining Front Seats	39
Recommended Fluids, Lubricants and Genuine Parts	205
Recreational Towing	135
Reformulated Gasoline	122
Refrigerant	187
Release, Hood	62
Remote Keyless Entry	36
Replacement Tires	115
Reporting Safety Defects	241
Restraints, Child	20
Rocking Vehicle When Stuck	99

Roof Rack	61
Rotation, Tires	117
Safety Checks Inside Vehicle	30
Safety Checks Outside Vehicle	30
Safety Tips	29
Scheduled Maintenance	208
Seat Belts	11
Seat Belts and Pregnant Women	11
Seat Belts	
Child Restraint	20,21
Extender	11
Front Seat	11
Inspection	11
Rear Seat	14,15
Reminder	14,15
Seats	
Adjustment	11
Head Restraints	11

Power	
Rear Folding	
Rear Seat Cushion Removal	
Reclining	
Selection of Oil	
Stee-Trac Operation	
Service Assistance	
Service Manuals	
Shift Indicator Light	
Shifting	
Automatic Transmission	
Manual Transmission	
Transfer Case	
Shoulder Belts	
Snow Plow	
Sound Systems	
Spare Tire	
Spark Plugs	

Power	41	Specifications	
Rear Folding	42	Engine	203
Rear Seat Cushion Removal	43	Fuel	121
Reclining	39	Oil	160
Selection of Oil	160	Speed Control	55
Selec-Trac Operation	103	Speedometer	75
Service Assistance	238	Starting	94
Service Manuals	243	Engine Block Heater	95
Shift Indicator Light	74,79	Engine Fails to Start	95
Shifting		Steering Wheel, Tilt	53
Automatic Transmission	100	Steering	
Manual Transmission	99	Column Controls	51
Transfer Case	104,108	Column Lock	9
Shoulder Belts	14	Power	180
Snow Plow	133	Storage, Vehicle	180
Sound Systems	80	Stuck Freeing	99
Spare Tire	142	Sunglass Storage	59
Spark Plugs	171	Tachometer	76

Taillights	194
Temperature Gauge, Engine Coolant	75
Tie Down Hooks, Cargo	66
Tilt Steering Column	53
Tires	30,113
Air Pressure	113
Alignment And Balance	117
Chains	118
Changing	141
Compact Spare	145
Inflation Pressures	113
Jacking	145
Replacement	115
Rotation	117
Spare Tire	142
Tread Wear Indicators	116
Warnings	148
Wheel Mounting	141
Wheel Nut Torque	146

Tongue Weight/Trailer Weight	129
Torque Converter Clutch	102
Tow Hooks, Emergency	190
Towing	127
Disabled Vehicle	191
Recreational	138
Trac-Lok Rear Axle	109
Trailer Towing	127
Hitches	138
Minimum Requirements	138
Tips	128,138
Trailer And Tongue Weight	138
Warnings	138
Wiring	138
Transfer Case	103,138
Transmission	98,100,172,173
Automatic	100,172
Capacities	172
Fluid	172,173

Manual	10
Shifting	10
Tread Wear Indicators	116
Trip Odometer	10
Turn Signals	10
Underbody Maintenance	10
Seatbelts	10
Unleaded Gasoline	10
Upholstery Care	10
Exterior Mirrors	10
Insurance, Compass	10
Vehicle Dimensions	10
Vehicle Identification Number	10
Vehicle Storage	10
Wind Quarter Window	10
Insulation System	10
Interior Trim	10

- | | | | |
|-------------------------------------|---------------|-----------------------------------|-------|
| Manual | 98,172 | Voltmeter | 76 |
| Shifting | 99,100 | Warning Flasher, Hazard | 139 |
| Tread Wear Indicators | 116 | Warning Lights | 73,77 |
| Trip Odometer | 76 | Warnings and Cautions | 6 |
| Turn Signals | 51,75,193,194 | Warranty Information | 241 |
| Underbody Maintenance | 189 | Washers, Windshield | 51 |
| Seatbelts | 14 | Washing Vehicle | 190 |
| Unleaded Gasoline | 121 | Waxing and Polishing | 190 |
| Upholstery Care | 191 | Wheel Alignment and Balance | 117 |
| Vanity Mirrors | 46 | Wheel Changing | 141 |
| Vehicle, Compass | 60 | Wheel Nut Torque | 146 |
| Vehicle Dimensions | 203 | Windows | 37 |
| Vehicle Identification Number | 6 | Power | 38 |
| Vehicle Storage | 180 | Vented Quarter | 37 |
| Vented Quarter Window | 37 | Windshield Defogging | 88 |
| Ventilation System | 89 | Windshield Defroster | 30,88 |
| Wheel Trim | 191 | Windshield Washers | 51 |
| | | Fluid | 181 |

Windshield Wiper Blades 182
Windshield Wipers 51,182
Wipers, Intermittent 52
Wrecker Towing 151

119,178 →

NOTES

119,178 → 29-01-2018 (10 l = 60-70 μm), (37-44 mi); ^{119,215}
_{119,222}



1996 Jeep Cherokee

W a r r a n t y I n f o r m a t i o n

IMPORTANT

This booklet contains Chrysler Corporation limited warranties . It should be kept in your vehicle and presented to your Dealer if any warranty service is needed.





WARRANTY COVERAGES AT A GLANCE

DESCRIPTION	1 Yr/ 12,000	2 Yr/ 24,000	3 Yr/ 36,000	3 Yr/ 50,000	7 Yr/ 70,000	7 Yr/ 100,000	8 Yr/ 80,000
Basic Coverage	■	■	■				
Special Extended Warranty Coverage							
Anti-Corrosion	■	■	■	■	■	■	■
Federal Emission Warranty	■	■					
Federal Emission Warranty - Specified Components	■	■	■	■	■	■	■
California Emission Warranty	■	■	■	■			
California Emission Warranty - Specified Components	■	■	■	■	■		

This booklet explains the different warranties that may apply to your new vehicle. It explains exactly what's covered...how long each kind of warranty lasts...and what you must do to keep the warranties in force.

TABLE OF CONTENTS

Warranty Coverages At A Glance	1	Corrosion Limited Warranty	18
1996 New Vehicle Limited Warranties	3	Federal Emission Warranties	19
3/36 Basic Warranty	6	California Emission Warranty	22
How To Get Warranty Service	11	Optional Service Contracts	30
How To Deal With Warranty Problems	13	Maintenance Log	31
Chrysler Customer Center	15	Owner Change of Name & Address Card	33
About Your Warranty	16		

Your Legal Rights Under Warranties:

All of the Chrysler Limited Warranties in this book are the only express warranties applicable to the vehicle. You have specific legal rights under these warranties which vary from state to state. You may have some implied warranties in the state in which you purchase the vehicle. For example,

1. An "implied warranty" that the vehicle is reasonably fit for the purpose for which it was sold; or
2. An "implied warranty" that the vehicle is fit for the purpose (that your vehicle is fit for the purpose)

Our Legal Rights Under Chrysler's Limited Warranties:

All of the Chrysler Limited Warranties stated in this book are the only express warranties made by Chrysler applicable to the vehicle. These Limited Warranties give you specific legal rights and you may also have other rights which vary from state to state.

You may have some implied warranties, depending on the state in which your vehicle is registered. For example,

1. An "implied warranty of merchantability", (that your vehicle is reasonably fit for the general purpose for which it was sold); or
2. An "implied warranty of fitness for a particular purpose" (that your vehicle is suitable for your

special purposes if your special purposes were specifically disclosed to Chrysler itself (not merely to the dealer) prior to purchase.)

These implied warranties are limited, to the extent allowed by law, to the time period(s) covered by the written warranties set forth in this booklet. If this vehicle is used primarily for business or commercial purposes, then these implied warranties do not apply and are completely disclaimed to the extent allowed by law. There is no implied warranty of fitness for a particular purpose including racing of vehicles equipped for that purpose.

Some states do not allow limitations on how long an implied warranty lasts, so the above limitations may not apply to you.

WHAT'S COVERED

The **"Basic Warranty"** begins on your vehicle's **Warranty Start Date** which is the earlier of (1) the date you take delivery of your new vehicle, **OR** (2) the date the vehicle was first put into service (for example, as a dealer "Demo" or as a Chrysler company vehicle).

The **"Basic Warranty"** covers the cost of all parts and labor needed to repair any item on your vehicle (except as noted below) that's defective in material, workmanship, or factory preparation. You pay nothing for these repairs.

The **"Basic Warranty"** covers every Chrysler supplied part of your vehicle, **EXCEPT** its tires and cellular telephone. The cellular telephone and the tires are

covered by separate warranties offered by their makers. See these warranty statements in your Owner's Literature Package.

The **"Basic Warranty"** covers your vehicle **ONLY IF** (1) it's registered in the U.S., (2) it's driven mainly in the U.S. or Canada, (3) it was built to U.S. or Canadian emissions specifications, and (4) it's operated and maintained in the manner described in your **"Owner's Manual"**.

These warranty repairs or adjustments (parts and labor) will be made by your dealer at no charge using new or remanufactured parts.

NOTE: Chrysler will not cover vehicles exported from sales areas by individuals or Chrysler or its authorized dealers. Vehicles previously registered in the U.S. or Canada prior to export are not covered unless required by law.

Those vehicles registered in military personnel on assignment areas are not covered. Vehicles registered in foreign countries and territories are not covered. This warranty is not applicable.

NOTE: Chrysler will not provide warranty coverage for vehicles exported from the U.S. or Canada to foreign areas by individuals or organizations other than Chrysler or its authorized distributors, unless these vehicles were previously registered and actually used in the U.S. or Canada prior to their export, except as required by law.

Those vehicles registered to U.S. government officials or military personnel on assignment are exempt from this policy. Vehicles registered and operated in U.S. possessions and territories are subject to U.S. warranties as applicable.

Towing

Your warranties cover the cost of towing your vehicle to the nearest Chrysler Corporation Dealer, if your vehicle can't be driven because of a failure of a covered part.

1996 NEW VEHICLE LIMITED WARRANTY

The "**Basic Warranty**" lasts for 36 months from the vehicle's Warranty Start Date **OR** for 36,000 miles on the odometer, whichever occurs first.

The following items are only covered for 12 months or 12,000 miles on the odometer, whichever occurs first:

- Brakes (Rotors, Pads Linings and Drums)
- Wiper Blades
- Clutch Discs

WHAT'S NOT COVERED

Modifications & Alterations

Certain changes that you make to your vehicle, even if they are not in and of themselves, void the warranty described in this booklet. Such changes are not limited to:

the installation of non-original equipment (such as a speed control);

the modification of the vehicle's components; and

the use of special (non-approved) additives.

WHAT'S NOT COVERED

Modifications & Alterations Excluded

Any changes that you might make to your vehicle do in and of themselves, void the limited warranties described in this booklet. Such changes may include, but are not limited to:

- the installation of non-Chrysler parts, components or equipment (such as a non-Chrysler radio or speed control);
- the modification of the vehicle or one or more of its components; and
- the use of special (non-Chrysler) materials or additives.

However, your Chrysler Warranties don't cover any part which is not a Chrysler supplied part. These warranties also don't cover the costs of any repairs or adjustments that might be caused by or needed because of the use or installation of non-Chrysler parts, equipment, materials or additives.

Examples of the types of alteration that are not covered include, but are not limited to the installation of accessories (except for genuine MOPAR accessories approved by Chrysler for dealer installation) such as sun roofs, window tinting, trailer hitches, theft alarm systems, rustproofing or other protection products, or the use of any refrigerant other than that approved by Chrysler.

1996 NEW VEHICLE LIMITED WARRANTIES

NOTE: Disconnecting, tampering with or altering the odometer will void your Chrysler warranties, unless your repairing technician follows the legal requirements for repairing or replacing odometers. Attaching any device which disconnects the odometer will also void your Chrysler warranties.

Environmental Factors Excluded

Your Chrysler warranties don't cover the costs of repairing damage caused by environmental factors or acts of God. "Environmental factors" include such things as airborne fallout, chemicals, tree sap, salt, ocean spray, acid rain, and road hazards. "Acts of God" include such things as hailstorms, windstorms, tornadoes, sand-storms, lightning, floods, and earthquakes.

Maintenance Costs Excluded

Your Chrysler warranties don't cover the costs of repairing damage caused by poor or improper maintenance. They also don't cover damage caused by the use of contaminated fuels, or the use of fuels, oils, lubricants, or fluids other than those recommended in your "Owner's Manual".

Your Chrysler warranties don't cover the costs of normal/scheduled maintenance of your vehicle. They don't cover the cost of lubrication, replacing filters, coolant, spark plugs or fuses unless done as the result of a covered repair, nor do they cover the cost of engine tune-ups, cleaning and polishing, worn wiper blades, worn brake pads and linings or clutch linings. These are some of the normal maintenance parts and services all vehicles require.

Your Chrysler warranties do not cover incidental or consequential damage to your vehicle under warranty, including but not limited to: lost time; inconvenience; rental of a replacement vehicle; the cost of rental or lodging; the loss of personal property; the loss of revenue, etc.

NOTE: Some states do not allow certain limitations or exclusions of incidental or consequential damage.

Your Chrysler warranties don't cover any "incidental or consequential damages" connected with the failure of your vehicle under warranty. Such damages include lost time; inconvenience; the loss of the use of your vehicle; the cost of rental cars, gasoline, telephone, travel or lodging; the loss of personal or commercial property; the loss of revenue, etc.

NOTE: Some states do not allow the exclusion or limitation of incidental or consequential damages, so the above limitations or exclusion may not apply to you.

Racing Excluded

Your Chrysler warranties don't cover the costs of repairing damage or conditions caused by racing, nor do they cover the repair of any defects which are found as the result of participating in a racing event. They don't cover fire or accident, abuse or negligence, misuse (e.g., driving over curbs, overloading, etc.); by tampering with the odometer, with the emissions systems or with other parts that could affect these systems; by improper adjustment or alteration; or by any changes made to your vehicle that don't comply with Chrysler specifications.

Total Loss, Salvage, Junk or Scrap Vehicles

This coverage is subject to title verification by Chrysler Corp. Any vehicle that is declared to be a total loss by any insurance company, is rebuilt after being declared to be a total loss, or is issued a certificate of title indicating that it is designated as "salvage", "junk", "rebuilt" "scrap" or words of similar impact will no longer have **any** warranty coverage. Chrysler will deny warranty coverage without notice if it finds that a vehicle is ineligible for coverage because it has been salvaged or declared a total loss as set forth in this paragraph.

Other Exclusions

Your Chrysler warranties don't cover the following: corrosion caused by accident, damage, abuse, or vehicle alteration; surface corrosion caused by such things as industrial fallout, sand, salt, hail and stones, etc.; corrosion caused by the extensive and/or abnormal transport of caustic materials like chemicals, acids, fertilizers, etc.; and the corrosion of special bodies, body conversions or equipment not made or supplied by Chrysler.

Your Chrysler warranties do not cover any non-Chrysler or non-MOPAR part installed on your vehicle.

Where to Take Your Vehicle to the Dealer
U.S., Mexico or Canada
recommends that you take your vehicle to the dealer who sold you the vehicle you bought it. Your Seller or Dealer will help you choose the best vehicle for your needs and ensure that you get the best service. However, any authorized Chrysler Dealer may work on your vehicle.

Except in emergencies (such as a breakdown), your Chrysler Corporation vehicle should be repaired **ONLY** by an authorized Chrysler Dealer.

Where to Take Your Vehicle to the Dealer
Foreign Countries. Chrysler dealers are authorized to provide service on vehicles operated temporarily in foreign countries or possessions or territories.

HOW TO GET WARRANTY SERVICE

Where to Take Your Vehicle for Warranty Service in the U.S., Mexico or Canada. In general, Chrysler recommends that you take your vehicle to the Dealer from whom you bought it. Your Selling Dealer knows you and your vehicle best; and he's the one most interested in making sure that you get prompt and high quality warranty service. However, any authorized Chrysler Corporation dealer may work on your vehicle.

Except in emergencies (see below), warranty service on your Chrysler Corporation vehicle may be performed **ONLY** by an authorized Chrysler Corporation Dealer.

Where to Take Your Vehicle for Warranty Service In Foreign Countries. Chrysler Corporation Dealers overseas are authorized to provide no-charge warranty service to vehicles operated **temporarily** outside the U.S. and its possessions or territories, but **registered in the U.S. and**

its possessions or territories at the time of repair. However, if an overseas Dealer charges you for warranty work, here's what you should do to get reimbursed:

1. Get a paid receipt from the Dealer; make sure that this receipt lists **ALL** the warranty repairs **AND** warranty parts that were involved. (This receipt will likely be a Warranty Repair Order much like the ones used by Chrysler Corporation dealers in this country.)
2. On your return home, contact the Chrysler Customer Center listed on page 15 and explain your request for warranty reimbursement.
3. If the Chrysler Customer Center asks you to do so, provide them with a copy of the receipt, your vehicle registration at time of repair, and any other relevant documents requested.

HOW TO GET WARRANTY SERVICE

Emergency Warranty Repairs. If you have an emergency and have to get a warranty repair made by other than an authorized Chrysler Corporation dealer, follow the reimbursement procedure given above for "Warranty Service in Foreign Countries".

Normally, warranty problems should be handled by the Dealer's sales or service department. You should always talk to your Sales Manager first. In the event of a dealer's response at the dealership's response at the dealership, that you follow these steps:

STEP 1: Discuss the problem with the Sales Manager of the dealership.

STEP 2: If your dealership cannot solve the problem, contact the Chrysler Corporation Customer Service Center at the address on page 15 of this manual.

A Chrysler representative will review the facts. If Chrysler cannot resolve the problem, you may wish to consult you in this matter, your dealer.

HOW TO DEAL WITH WARRANTY PROBLEMS

Normally, warranty problems can be resolved by your Dealer's sales or service departments. That's why you should always talk to your Dealer's Service Manager or Sales Manager first. If you're not satisfied with the dealership's response at this level, Chrysler recommends that you follow these steps, in order:

STEP 1: Discuss the problem with the owner or General Manager of the dealership.

STEP 2: If your dealership is unable to resolve the problem, contact the Chrysler Customer Center; you'll find the address on page 15 of this booklet.

A Chrysler representative at the headquarters office will review the facts. If Chrysler can take further action to assist you in this matter, your dealer will be provided the infor-

mation and assistance necessary to resolve the problem. In any case, your contact will be acknowledged and an explanation of Chrysler's position will be provided.

If you're unable to resolve your warranty problem through these two steps, you may choose to contact the Chrysler Customer Arbitration Board (CAB) in your area. See the "**Customer Arbitration Board**" brochure that was shipped with your vehicle. This service is strictly voluntary, and you need not submit your problem to the CAB before taking other actions.

HOW TO DEAL WITH WARRANTY PROBLEMS

NOTE: In some states, laws have been enacted that permit you to obtain a replacement vehicle or a refund of the vehicle purchase price under certain circumstances. The provisions of these laws vary from state to state. **If allowed by state law in your state, Chrysler requires that you first provide us with a written notification of any service difficulty you may have experienced so that we may have an opportunity to make any needed repairs before you are eligible for remedies provided by these laws.** In all other states, we request that you give us a written notice of any service difficulty. Your written notification should be sent to the Chrysler Customer Center as listed on page 15.

UNIT
CHRYSLER CU

P.O. B
CIMS

AUBURN HI

PHONE:

CHRYSLER CUSTOMER CENTERS

**CHRYSLER CANADA
CUSTOMER SERVICE**

Chrysler Centre
P.O. Box 1621
Windsor, Ontario N9A 4H6
Phone: (800) 465-2001

**CHRYSLER DE MEXICO
CUSTOMER RELATIONS**

Lago Alberto #320
Mexico 11320, D.F.
In Mexico (915) 729-1248
Outside Mexico (525) 729-1248

**PUERTO RICO & U.S. VIRGIN ISLANDS
CUSTOMER SERVICE**

Chrysler International Services, S.A.
Box 191857
San Juan, Puerto Rico 00919-1857
Phone: (809) 782-5757

**INTERNATIONAL
CUSTOMER RELATIONS**

P.O. Box 301
Center Line, Michigan 48015-9301
United States of America
Phone: (810) 497-1353

**UNITED STATES
CHRYSLER CUSTOMER CENTER**

**P.O. BOX 21-8004
CIMS 429-03-03**

AUBURN HILLS, MI 48321-8004

PHONE: (800) 992-1997

ABOUT YOUR WARRANTY

Warranty Repairs - Components Exchanges

In the interest of customer satisfaction, Chrysler may offer exchange service on some vehicle components. This service is intended to reduce the amount of time your vehicle is not available for use due to repairs. Components used in exchange service may be new, remanufactured, reconditioned or repaired, depending on the component involved.

All exchange components used meet Chrysler standards and have the same warranty as new components. Examples of the types of components that might be serviced in this fashion include: engine assemblies, transmission assemblies, instrument cluster assemblies, radios, tape and CD players, speedometers and powertrain control modules.

Also, in cooperation with worldwide efforts to control suspected ozone depleting agents, the EPA requires the capture, purification and reuse of automotive air conditioning refrigerant gases. As a result, any repairs to the sealed portion of your air conditioning system (if equipped) may involve the installation of purified reclaimed refrigerant.

Pre-Delivery Service

Defects in or damage to the mechanical, electrical, sheet metal, paint, trim and other components of your vehicle may occur at the factory or while it is being transported to the dealer.

Normally, any defect or assembly is detected and the inspection process. Inspected to inspect each vehicle repair any uncorrected factory transit damage detected delivered to you.

Production Changes

Chrysler and its dealers recognize changes in vehicles built at any time without incurring an or similar changes on vehicles sold by them.

ABOUT YOUR WARRANTY

Normally, any defect or damage occurring during assembly is detected and corrected at the factory during the inspection process. In addition, dealers are obligated to inspect each vehicle before delivery. They repair any uncorrected factory defects or damage and any transit damage detected before the vehicle is delivered to you.

Production Changes

Chrysler and its dealers reserve the right to make changes in vehicles built and/or sold by them at any time without incurring any obligation to make the same similar changes on vehicles previously built and/or sold by them.

CORROSION WARRANTY

The “**Corrosion Warranty**” covers the sheet metal parts of your vehicle. This warranty has two different time-and-mileage limits. These limits are counted from your vehicle’s Warranty Start Date.

1. For **any** body sheet metal panel, the limits are 36 months, unlimited mileage.
2. For **outer-body** sheet metal panels, the limits are 7 years or 100,000 miles on the odometer, whichever occurs first. An outer-body sheet metal panel is a sheet metal panel that can be seen by a person walking around the vehicle and that is finish painted.

The “**Corrosion Warranty**” covers the cost of all parts and labor needed to repair or replace any sheet metal panels of your vehicle that become perforated (rusted through) by corrosion.

Corrosion (Rust-Through) Coverage

The corrosion coverage applies to perforation due to corrosion only. Perforation means a rust-through condition, such as an actual hole in a sheet metal panel pillar or post. Cosmetic or surface corrosion (resulting from stone chips or scratches in the paint, for example) would not be repaired under this coverage.

The **Federal Emissions** components (if so equipped) are covered for 8 years or 24,000 miles, whichever occurs first, under the vehicle Warranty Start Date.

- AIR system controls
- distributor/components
- electronic fuel injection system including injector
- exhaust manifold
- evap emission canister & controls
- exhaust gas recirculation valve & control system
- exhaust pipes (between exhaust manifold & catalytic converter)

FEDERAL EMISSION WARRANTY

The **Federal Emissions Warranty** covers the following components (if so equipped) of your vehicle for a period of 2 years or 24,000 miles, whichever occurs first counted from the vehicle Warranty Start Date.

- AIR system controls
- distributor/components
- electronic fuel injection system including injector
- exhaust manifold
- evap emission canister & controls
- exhaust gas recirculation valve & control system
- exhaust pipes (between exhaust manifold & catalyst)
- positive crankcase ventilation (PCV) valve or orifice
- secondary ignition wires
- spark plugs
- throttle body
- transmission control module
- vacuum hoses, clamps fittings & tubing used for these components
- fuel cap & tank assembly, pump & fuel lines
- ignition coil/module
- intake manifold
- on-board diagnostic system components
- oxygen sensors
- vacuum, temperature, altitude, speed, time-sensitive valves, sensors & switches used in these components & systems

FEDERAL EMISSION WARRANTY

The **Federal Emissions Warranty** covers the following components (if so equipped) of your vehicle for a period of 8 years or 80,000 miles, whichever occurs first counted from the vehicle Warranty Start Date.

— catalytic converter

— powertrain control
module

Vehicles equipped with a California Certified Emission Control System and registered in the states of California or Massachusetts are also entitled to the California Emission Warranty. (See page 22 of this booklet.)

In addition to the components listed on the prior page, for a period of 2 years or 24,000 miles on the odometer (whichever occurs first), the **"Performance Warranty"** covers the cost of repairing or adjusting **any components or parts** that might be needed to allow your vehicle to pass Federal Emission Standards for a Federally-approved state or local emissions (I/M) test, but **ONLY IF**:

1. Your vehicle has failed to meet Federal Emission Standards for a Federally-approved state or local emissions test;
2. Your vehicle had been maintained and operated properly, up until the time of testing; and
3. You face a real penalty (for example, a fine or the loss of the use of your vehicle) because of the vehicle's failure to pass the local emissions test.

Getting Service Under

1. Take your vehicle to the nearest authorized Service Station or Dealer as soon as you fail an emissions test.
2. Give the service representative a copy of the maintenance logs that your vehicle failed.
3. It is recommended that you keep maintenance logs on your vehicle. If your vehicle has been maintained properly, you may be required to show

FEDERAL EMISSION WARRANTY

Getting Service Under The "Performance Warranty":

1. Take your vehicle to an authorized Chrysler Corporation Dealer as soon as possible after it's failed the emissions test.
2. Give the service representative the print-out showing that your vehicle failed the test.
3. It is recommended that you have all service receipts, maintenance logs and records that prove that your vehicle has been maintained properly, since you may be required to show them.

NOTE: If you feel your dealer has denied you emissions warranty coverage, contact Chrysler Corporation. Follow the steps listed on page 13. Chrysler will notify you in writing within 30 days (or within the time limit required by local or state law).

4. If you want more information about getting service under the "Emission Control Systems Performance Warranty", or if you want to report what you feel is a violation of the terms of this warranty, you may contact:

**Director
Field Operation & Support Division
(6406J)
Environmental Protection Agency
401 M Street SW
Washington, D.C. 20460
ATTN: Warranty Claim**

FEDERAL EMISSION WARRANTY

California Emission Control Warranty Statement

Your Warranty Rights and Obligations (Applies Only to Vehicles Certified for Sale and Registered in the State of California)

The California Air Resources Board is pleased to explain the emission control system warranty on your 1996 model vehicle. In California, new motor vehicles, must be designed, built and equipped to meet the State's stringent anti-smog standards. Chrysler must warrant the emission control system on your vehicle for the periods of time listed below provided there has been no abuse, neglect or improper maintenance of your vehicle.

Your emission control system may include parts such as the fuel-injection system, the ignition system, catalytic

converter, and powertrain control module. Also included may be hoses, belts, connectors and other emission-related assemblies.

Where a warrantable condition exists, Chrysler will repair your vehicle at no cost to you including diagnosis, parts and labor.

MANUFACTURER'S WARRANTY COVERAGE:

For 3 years or 50,000 miles whichever first occurs:

1. If your vehicle fails a Smog Check inspection, all necessary repairs and adjustments will be made by Chrysler to ensure that your vehicle passes the inspection. This is your emission control system **PERFORMANCE WARRANTY.**

2. If any emission-related part is found to be defective, the part will be replaced by Chrysler. This is your emission control system **DEFECTS WARRANTY.**

For 7 years or 70,000 miles whichever first occurs:

1. If an emission-related part is found to be defective, the part will be replaced by Chrysler. This is your emission control system **DEFECTS WARRANTY.**

CALIFORNIA EMISSION WARRANTY

2. If any emission-related part on your vehicle is defective, the part will be repaired or replaced by Chrysler. This is your short-term emission control system **DEFECTS WARRANTY**.

For 7 years or 70,000 miles whichever first occurs:

1. If an emission-related part listed in this warranty booklet specially noted with coverage for 7 years or 70,000 miles is defective, the part will be repaired or replaced by Chrysler. This is your long-term emission control system **DEFECTS WARRANTY**.

OWNER'S WARRANTY RESPONSIBILITIES:

- As the vehicle owner, you are responsible for the performance of the **required maintenance listed in your owner's manual**. Chrysler recommends that you retain all receipts covering maintenance on your vehicle, but Chrysler cannot deny warranty **solely** for the lack of receipts or for your failure to ensure the performance of all scheduled maintenance.
- You are responsible for presenting your vehicle to a Chrysler Corporation dealer as soon as a problem exists. The warranty repairs should be completed in a reasonable amount of time, not to exceed **30 days**.
- As the vehicle owner, you should also be aware that Chrysler may deny you warranty coverage if your vehicle or a part has failed due to abuse, neglect, improper maintenance or unapproved modifications.

CALIFORNIA EMISSION WARRANTY

If you have any questions regarding your warranty rights, and responsibilities, you should contact Customer Relations (714) 565-5200 (Southern California) or (510) 463-0656 (Northern California) or the California Air Resources Board at 9528 Telstar Avenue, El Monte, CA 91731.

Coverage:

Chrysler Corporation (Chrysler) warrants that any vehicle certified for sale and registered in the State of California is designed, built and equipped to conform with the emissions standards adopted by the California Air Resources Board. Chrysler warrants that this vehicle is free from defects in materials and workmanship which would cause any part which affects emissions on this vehicle to fail to conform with applicable requirements or to fail to pass a required state smog check test for three

years or 50,000 miles, whichever occurs first. Chrysler also warrants that any part, on the long-term warranted emissions parts list in this warranty and installed as original equipment, is free from defects in material and workmanship which would cause this vehicle to fail to conform with applicable regulations for seven years or 70,000 miles, whichever first occurs.

Warranty Service

To obtain warranty service, return the vehicle to any authorized Chrysler Corporation dealer. Service will be performed without charge for diagnosis, parts and labor. If traveling, warranty service may be obtained from any authorized Chrysler Corporation Dealer. It is recommended that you return to a dealer who sells the same make vehicle. In case of emergency, see Emergency Service Instructions.

Exclusions

This warranty does not cover tampering or lack of maintenance which the odometer mileage does not reflect or vehicle's actual mileage.

Statement of Owner's

What is covered by the

If a vehicle fails a state smog check during the warranty coverage period, Chrysler will pass a state Smog Check. You must take the vehicle to any authorized Chrysler Dealer for warranty repair.

CALIFORNIA EMISSION WARRANTY

Exclusions

This warranty does not apply to failures caused by abuse, tampering or lack of maintenance; or to any vehicle on which the odometer mileage has been altered so that the vehicle's actual mileage cannot be determined.

Statement of Owner's Rights and Obligations

What is covered by the Warranty:

If a vehicle fails a state Smog Check test during the coverage period, Chrysler will repair the vehicle so that it will pass a state Smog Check re-test. The owner should take the vehicle to any authorized Chrysler Corporation Dealer for warranty repairs and give a copy of the failed

Smog Check test report to the dealer. If the owner is not notified within 30 days that a performance warranty claim is denied, the manufacturer must repair the vehicle free of charge.

After the 3 year/50,000 mile performance warranty period has passed, a Smog Check test failure due to a defect in a part which is warranted for 7 years/70,000 miles is covered.

If a warranted part fails because of a defect, Chrysler will repair or replace it at any authorized Chrysler Corporation Dealer. Any other parts damaged by the failure of a defective part will also be repaired or replaced. The repair and/or replacement will be made at no charge to the owner for parts, labor and diagnosis. For emergency situations, see the instructions under Emergency Service.

CALIFORNIA EMISSION WARRANTY

Parts:

It is recommended that any replacement parts used for maintenance or for the repair of emissions control systems be new or remanufactured genuine Chrysler/MOPAR parts. However, the warranty obligations are not dependent upon the use of any particular brand of replacement parts. The owner may choose to use non-genuine Chrysler/MOPAR parts for maintenance purposes. Use of replacement parts which are not of equivalent quality may impair the effectiveness of emissions control systems.

What is not covered by Emission Warranty:

The Warranty does not cover:

- Malfunctions in any part caused by misuse, alteration, tampering, disconnection or improper or inadequate maintenance.

- Damage due to use of leaded gasoline.
- Damage resulting from fire, accident, negligence, act of God or other events beyond the control of Chrysler.
- Maintenance replacement parts (such as spark plugs) beyond the first scheduled replacement point.
- Consequential damages such as loss of use of the vehicle, loss of time, inconvenience, expense for gasoline, telephone, travel or lodging.
- Any vehicle on which the odometer mileage has been altered so that actual vehicle mileage cannot readily be determined.
- Loss or damage to personal property, loss of revenue, commercial loss or other matter not specifically included.
- Damage resulting from the use of a non-genuine Chrysler/MOPAR part.

Emergency Service

If emergency Emission Control System Warranty service is required and an authorized servicing Chrysler Corporation dealer is not readily available, Chrysler recommends that you use the following procedure:

- Contact the Chrysler Customer Center and request emission warranty service help. The location and telephone number of the Customer Center is listed in the owner's manual provided with the vehicle.
- The Chrysler Customer Center will recommend an authorized servicing dealer or help in locating a qualified independent service dealer.
- Arrangements for reimbursement to the owner for independent servicing dealer emergency repairs (including labor) should be made with the Chrysler

Customer Center during the original contact. (Replaced parts and a paid original invoice will be required in these cases.)

- Any questions about the emission control systems warranty should be reviewed with the Chrysler Customer Center.

If emergency Emission Control Warranty service is required and an authorized Chrysler Corporation dealer is not readily available, the owner or any available service establishment may perform the repair and any non-Chrysler replacement part may be used. Chrysler will repay the owner for repairs covered by this warranty including diagnosis. Parts repayment is at Chrysler's suggested retail price. Labor charges are based on Chrysler's recommended time allowance for the warranty repair and the geographically appropriate hourly labor rate. A part not being available within 30 days or a repair

not being completed with
Replaced parts and paid re
for presentation to the C
condition of reimburseme
In addition, the owner r
detailed description indi
considered an emergency
available.

CALIFORNIA EMISSION WARRANTY

not being completed within 30 days is an emergency. Replaced parts and paid receipts must be readily available for presentation to the Chrysler Customer Center as a condition of reimbursement for these emergency repairs. In addition, the owner must provide Chrysler with a detailed description indicating why the situation was considered an emergency and why dealer service was unavailable.

Listed below are components WARRANTED AGAINST DEFECTS IN MATERIAL AND WORKMANSHIP FOR 7 years or 70,000 miles on vehicles/engines as noted.

Catalyst
Exhaust Manifold - 4.0L
Intake Manifold - 4.0L
Powertrain Control Module

OPTIONAL SERVICE CONTRACT

Chrysler's optional **Service Contracts** offer valuable repair-cost protection when these warranties do not apply. They compliment the warranties detailed in this booklet. Several plans are available; they cover different periods (time and mileage) and different sets of components. Ask your Chrysler Corporation Dealer for details. Chrysler Service Contracts are not available to customers living in U.S. possessions or territories. Chrysler Service Contract protection does not replace any coverage under the limited warranties in this booklet.

You are responsible for operating your new vehicle. The maintenance guidelines contained in the General Service guidelines in your scheduled maintenance operation. A Maintenance Convenience on page 32 of the continued warranty coverage scheduled maintenance operation. Your Maintenance Log documentation. We recommend calling your Selling Dealer for all your service needs before and after the warranty period. Your Selling Dealer will provide all your service warranty service on your vehicle. Only the dealer who sells that make or model

MAINTENANCE LOG

You are responsible for properly maintaining and operating your new vehicle. Follow the instructions contained in the General and Scheduled Maintenance service guidelines in your Owner's Manual. Regular scheduled maintenance is essential to trouble-free operation. A Maintenance Log is provided for your convenience on page 32 of this booklet. To insure your continued warranty coverage, you should keep track of scheduled maintenance either through routinely filling out your Maintenance Log or retaining receipts or other documentation. We recommend that you return to your Selling Dealer for all your maintenance service both during and after the warranty periods. Returning to your Selling Dealer will help assure your satisfaction and provide all your service needs. However, you may not warranty service on your vehicle from any dealer who sells that make or model.

Repairs required due to neglect, improper or inadequate maintenance are not covered by your warranties.

This information replaces

FUSE PANEL

The fuse panel is located
on the left of the steering

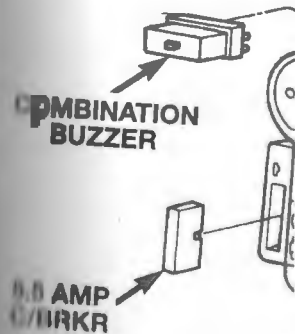

1996 Owner's Manual Addendum Card

This information replaces the Fuse Panel information on pages 200, 201 and 202 in the 1996 Jeep Cherokee Owner's Manual.

FUSE PANEL

The fuse panel is located beneath the instrument panel on the left of the steering wheel.

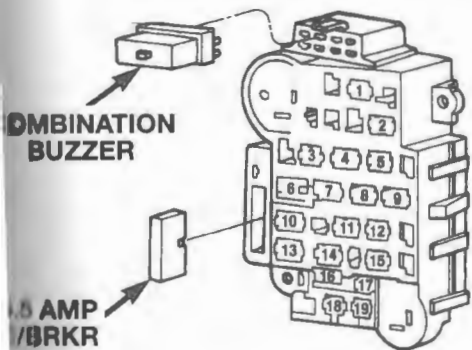

Cavity	Amp/Color	Items Fused
1	25 Amp Natural	Rear Wiper, Rear Washer
2	15 Amp Lt. Blue	Radio, Cigar Lighter
3	Empty	
4	15 Amp Lt. Blue	Passing Light
5	30 Amp Natural	Blower Motor
6	30 Amp C/BRKR	Power Windows
7	2 Amp Pink	Anti-lock Brakes
8	Empty	

Cavity	Amp/ Color	Items Fused
9	10 Amp Red	Radio/Clock & Memory, Courtesy Lights, Glove Box, Cargo, Dome Lights, Telltales
10	20 Amp Yellow	Turn Signal Flasher
11	25 Amp Natural	Headlight Delay Module, Horns
12	Empty	
13	20 Amp Yellow	Power Door Locks
14	Empty	
15	15 Amp Lt. Blue	Instrument Panel Lights, Clock, Radio/Clock & Memory, Headlight Switch, Park Lights
16	30 Amp C/BRKR	Power Seats, Trailer Tow
17	7.5 Amp Violet	Instrument Cluster Gauges, Headlight Delay Module, Chime Module, Overhead Console
18	25 Amp Natural	Heater Rear Window

Cavity	Amp/ Color	Items Fused
19	5 Amp Tan	Instrument Panel Lights, Radio Illumination
20	5.5 Amp C/BRKR	Windshield Wiper/Windshield Washer

81-016-9612

CHRYSLER CORPORATION

INSTALLATION OF EQUIPMENT

Special design consists of
vehicle's electronic
frequency signals. Most
equipment must be
nel. The following m

Power connections should
and fused as close to

Antennas for two-way
roof or the rear area
in mounting antenna
affect the accuracy
vehicles so equipped.

The antenna cable should
routed away from the
only fully shielded co

INSTALLATION OF RADIO TRANSMITTING EQUIPMENT

Special design considerations are incorporated into this vehicle's electronic system to provide immunity to radio frequency signals. Mobile two-way radios and telephone equipment must be installed properly by trained personnel. The following must be observed during installation.

Power connections should be made directly to the battery and fused as close to the battery as possible.

Antennas for two-way radios should be mounted on the roof or the rear area of the vehicle. Care should be used in mounting antennas with magnet bases. Magnets may affect the accuracy or operation of the compass on vehicles so equipped.

The antenna cable should be as short as practical and routed away from the vehicle wiring when possible. Use only fully shielded coaxial cable.

Carefully match the antenna and cable to the radio to ensure a low Standing Wave Ratio (SWR).

Mobile radio equipment with output power greater than normal may require special precautions.

All installations should be checked for possible interference between the communications equipment and the vehicle's electronic systems.



A Division of the Chrysler Corporation.
Jeep is a registered trademark of Chrysler Corporation.

Gas Station Reference

Fuel Selection

Gasoline Engines

Unleaded Gasoline - 87 octane or higher

Engine Oil - API Certified

(10W-30 is preferred)



81-326-9651

Second Edition

FLUID CAPACITIES

U.S.

Liters

Fuel

ALL 20.2 gal. 75.7L

Engine Oil (including filter)

2.5L Engine 4.0 qts. 3.8L

4.0L Engine 6.0 qts. 5.7L

Cooling System

2.5L Engine 10 qts. 9.5L*

4.0L Engine 12 qts. 11.4L*

*Includes 2.3 qts./2.2L for coolant recovery bottle.

Automatic Transmission Fluid

2.5L=MOPAR ATF PLUS (Automatic Transmission Fluid - Type 170) should be used to assure optimum transmission performance. Fluids of the type labeled DEXRON® III MERCON® should NOT be used unless the recommended fluid is not available.

4.0L=MOPAR Automatic Transmission Fluid (P/N 4773590) or equivalent labeled DEXRON® III MERCON® fluid.

Oil Filter

Mopar 5281090 or equivalent.

Spark Plug, Gap, Ignition Timing

Refer to "Vehicle Emission Control Information" label in engine compartment.

Tire Pressures

Refer to Inflation Pressure Brochure in the glove box kit

Printed in USA

Your 4WD Cherokee is equipped with one of these systems:

Selec-Trac®

The Selec-Trac 4WD system allows you to choose between 2WD and full-time 4WD for use year-round on hard-surfaced roads under most driving conditions. You may remain in full-time 4WD without damaging the system or reducing fuel economy. For even more traction to cope with very severe conditions such as deep snow, ice, or mud, you can shift into part-time 4WD. You can shift on-the-fly at any legal speed from 2WD to full-time or part-time 4WD.



Command-Trac®

The Command-Trac 4WD system provides part-time 4WD for off-highway driving or when road conditions are slippery. You may want to shift into 4 LO when off-highway driving conditions require added low-speed pulling power. These 4WD positions are for temporary use only when 4WD is needed. You can shift on-the-fly at any legal speed from 2WD to part-time 4WD.

TIP: When off-highway conditions require additional low-speed pulling power, you may want to shift into the 4 LO position. On both 4WD systems, when shifting into or out of 4 LO, slow the vehicle to 2-3 miles per hour, shift the transmission into N (Neutral), and shift the



transfer case lever firmly and quickly without pausing in the transfer case N (Neutral) position. You can then return the transmission to the desired gear. Do not use part-time 4WD or 4 LO on dry paved roads.

	Selec-Trac	CommandTrac
Dry Pavement	2WD or 4WD High Full-Time	2WD
Wet Pavement, Sand or Gravel	4WD High Full-Time or Part-Time	4WD High
Deep Snow or Mud	4WD High Part-Time	4WD High
Severe Conditions	4WD Low	4WD Low

Item no. 81-016-6057

Printed on recycled paper.



TRAIL LIGHTLY™
ON PUBLIC AND PRIVATE LAND

The Jeep and Eagle Division of Chrysler Corporation is totally committed to preserving the beauty and natural state of America's wildlands. For this reason, Jeep was a founding member of and cooperates fully with the "Trail Lightly" program started by the U.S. Forest Service and Bureau of Land Management. "Trail Lightly" sets certain commonsense guidelines for preserving the wilderness for us and for future generations.

Trail Lightly

Jamborees begin on Friday morning and end after breakfast on Sunday. There's one scheduled most weekends from spring to fall, coast-to-coast. For more information or a Jamboree Tour Guide, call 1-800-925-JEEP.

Jeep Jamborees

Every one of these exciting tours gives you a golden opportunity to see an America impossible to reach from a superhighway. You have a choice of breathtaking wilderness areas from the Rubicon Trail to the Appalachian Trail. And, more than ever before, you'll appreciate the amazing capabilities of your Jeep vehicle.

Jeep

TRAIL LIGHTLY™ IS A REGISTERED TRADEMARK OF CHRYSLER CORPORATION.

1996 Jeep Cherokee
Tips from the Jeep Product Team

Jeep Cherokee

Your Jeep Cherokee is a quality vehicle equipped with some of the most sophisticated technology and unique product features in the world. While the benefits of these features are readily apparent, the tips inside describe some of the outstanding features and provide helpful information. They are not meant to be a substitute for your Owner's Manual, which provides a detailed explanation of Cherokee and needs to be read carefully.

Air Bag

Your Cherokee has a driver's air bag† as a supplement to the seat belt restraint system. The air bag is mounted in the steering wheel and deploys in higher-speed frontal impacts. It works with the instrument panel, knee bolster, and the seat belt to provide supplemental protection for the driver. In collisions where the air bag deploys, the seat belt helps keep you positioned for the air bag to protect you properly. Therefore, always wear your seat belt even though you have an air bag. Please read the Owner's Manual and visor label for more information.



Automatic Transmission Park/Brake Interlock

For your safety, your automatic transmission-equipped Cherokee will not shift out of P (Park) without having the brake pedal depressed.

Keyless Entry System

Your Cherokee may be equipped with the optional Remote Keyless Entry System. The system is operated by an infrared beam between the handheld remote control and the receiver.

TIP: The receiver is a red-domed sensor located above the windshield and between the sun visors, so be sure to aim your remote control directly at this location. When equipped with the overhead console, the sensor is located as shown below.



Sensor with overhead console

Anti-Lock Brake System

Your Cherokee may be equipped with an anti-lock brake system (ABS). It is designed to help provide maximum braking performance and steering control under most driving conditions. Important tips to keep in mind:

TIPS: The brake pedal will vibrate or "pulse" indicating the ABS is working properly. The system is frequently activated during braking under certain road or stopping conditions such as ice, snow, gravel, bumps, railroad tracks, loose debris, and panic stops.

- Never "pump" your ABS brake pedal. Apply your brakes with smooth, constant pressure on the brake pedal. "Pumping" the brake pedal will result in reduced braking performance.

- The ABS motor will produce a low humming noise when it is operating

- The ABS tests itself, after the vehicle reaches a speed between 3-8 mph. When this occurs, you may hear the motor run and feel the brake pedal pulse.

- The brake pedal may drop slightly at the end of an ABS stop because the ABS automatically turns off at speeds below 3 mph.

- All vehicle wheels and tires must be the same size and type and be properly inflated to produce accurate signals for the computer.



Compass—Overhead Console

Some Cherokee models may be equipped with an overhead console compass. If the compass reading appears to be erratic and the "CAL" symbol is displayed, you will need to "recalibrate" the vehicle's compass. To do this, complete three 360 degree circles at slow speed in a driving area free of large metallic objects. If the compass appears erratic and the "CAL" symbol does not appear, follow the instructions in the Owner's Manual for "Manual Compass Calibration."

You may also wish to adjust or verify the compass reading based on your geographic location in relation to the North Pole. To fine-tune your compass for this purpose, follow the instructions for "Compass Variance" in the Owner's Manual.

Child-Protection Locks

If your Cherokee has four doors, the rear doors are equipped with child-protection locks. To activate the system, open rear doors and move the door-mounted control, located near the door latch, toward the outside of the vehicle to the "engage" position.

TIP: When this feature is activated, the rear doors cannot be opened from the inside of the vehicle. However the outside door handles will operate normally. Move the control inboard to disengage.

Rear Seat Folding And Removal

The rear seat of your Cherokee can be folded down to expand the rear cargo area. The rear seat cushion may also be removed for even more cargo area.

TIPS: The front seats may have to move forward to fold the seatback flat. You must fold the cushion up before folding the seatback down.

- To disengage the rear seat cushion from the lock, pull up on the seat cushion side loop. Loops are located on both sides of the cushion, near the seat belts. Move the seat cushion forward.

- Release the lock at either side of the seatback. Locks are located at the upper corners of the seatback. Fold the seatback flat.

- The seat cushion can be removed from the passenger side only. Open the door and pull up on the seat cushion side loop to release the cushion. Pull up on the pivot release lever and carefully pull the cushion toward you until the pin is removed from the pivot on the driver's side. The seat cushion can now be removed from the vehicle.

- Replacing the seat cushion is easier with two people, one to hold the cushion while the other guides the pin into the pivot.

Air Conditioning

Your Cherokee may be equipped with an air conditioning system. To cool your vehicle more quickly, follow these tips:

- Roll down front windows to help expel hot air from the vehicle. After vehicle has expelled hot air, roll up windows to prevent outside hot air from entering

- Temporarily set the upper level of the air conditioning control to MAX. The MAX setting cools and removes moisture quickly from the interior by recirculating the air already inside your vehicle.

- After reaching a comfortable cooling level, switch to NORM or BI-LEVEL setting. This allows for continued cooling of the vehicle with outside air.

For helpful illustrations, check the Owner's Manual.