

## STAR ONLINE PUBLICATION

---

**Case Number:** S1823000054

**Release Date:** 4/2/2020

**Symptom/Vehicle Issue:** Hood Flutter or Shake While Driving

**Discussion:** Follow the below adjustment steps to ensure hood stability

### 1. Fore-Aft hood adjustment

With the hood closed, confirm that the fore-aft hood bumpers have good contact. Bumpers are shown in fig 1. This can be done by pushing on the front of the hood in the bumper locations (fig 2). The hood should **not** flex in these locations. If the hood does flex and does not touch the bumpers, open the hood and turn the bumpers counterclockwise until desired contact. The design interference for these bumpers is 2mm.

This document does not authorize warranty repairs. This communication documents a record of past experiences. STAR Online does not provide any conclusions about what is wrong with the vehicle. Rather, it captures all previous cases known that appear to be similar or related to the vehicle symptom / condition. You are the expert, and you are responsible for deciding on the appropriate course of action.

**Contact STAR Center, or your Technical Assistance Center Via TechCONNECT or eCONTACT ticket if no solution is found**

## STAR ONLINE PUBLICATION

---

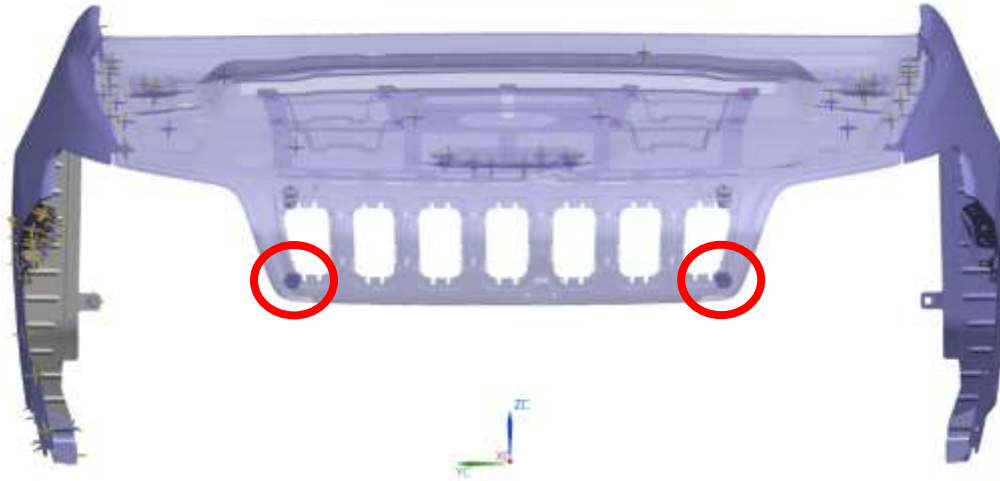

**Fig 1 fore-aft hood bumpers**

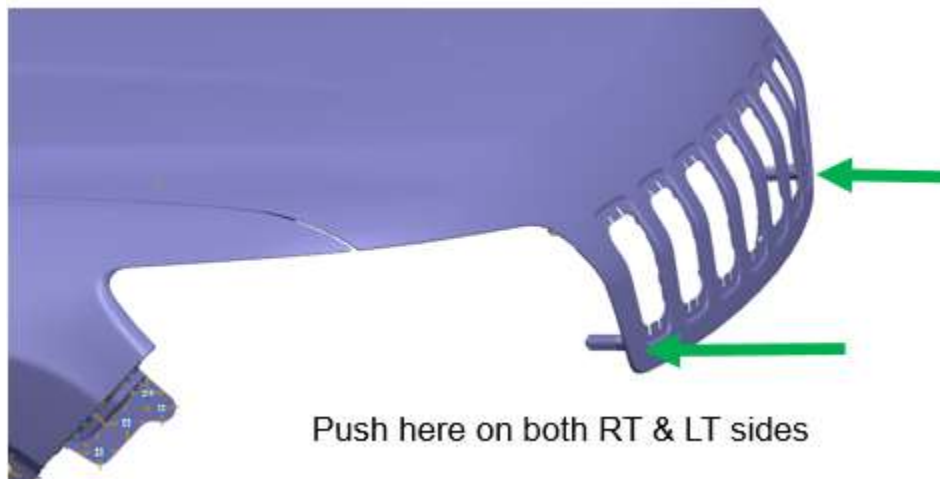

**Fig 2**

This document does not authorize warranty repairs. This communication documents a record of past experiences. STAR Online does not provide any conclusions about what is wrong with the vehicle. Rather, it captures all previous cases known that appear to be similar or related to the vehicle symptom / condition. You are the expert, and you are responsible for deciding on the appropriate course of action.

**Contact STAR Center, or your Technical Assistance Center Via TechCONNECT or eCONTACT ticket if no solution is found**

## STAR ONLINE PUBLICATION

### 2. Latch adjustment (fig 3)

With the hood open, adjust the latch to be centered and lowered to the full down position. This can be done by loosening the 2 bolts on the latch and gently lowering the hood into the secondary latch position. This will center the latch, and the latch should be loose enough to fall to its lower position. Open the hood and tighten the latch bolts to 11N.m.

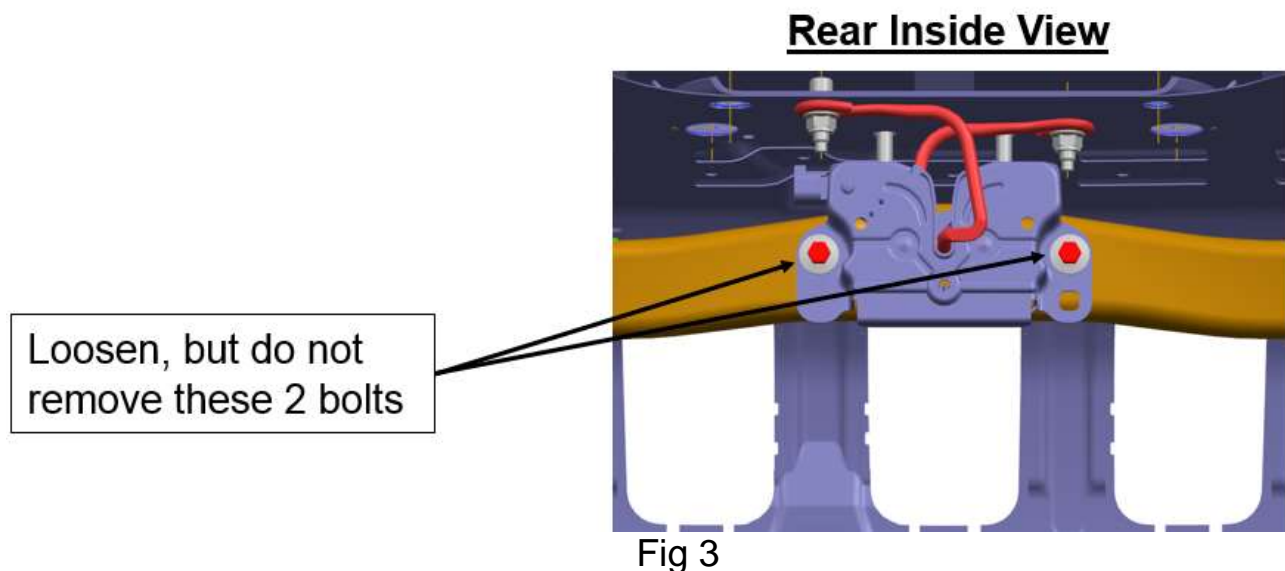

### 3. Hood flush check.

Close the hood and inspect the flushness of the hood, relative to fenders. The hood should be flush or slightly under flush along the fender cutline. If the hood is too far under flush, adjust the up/down hood bumpers to raise the hood. Turn the bumpers counterclockwise until desired flushness (fig 4)

This document does not authorize warranty repairs. This communication documents a record of past experiences. STAR Online does not provide any conclusions about what is wrong with the vehicle. Rather, it captures all previous cases known that appear to be similar or related to the vehicle symptom / condition. You are the expert, and you are responsible for deciding on the appropriate course of action.

**Contact STAR Center, or your Technical Assistance Center Via TechCONNECT or eCONTACT ticket if no solution is found**

## STAR ONLINE PUBLICATION

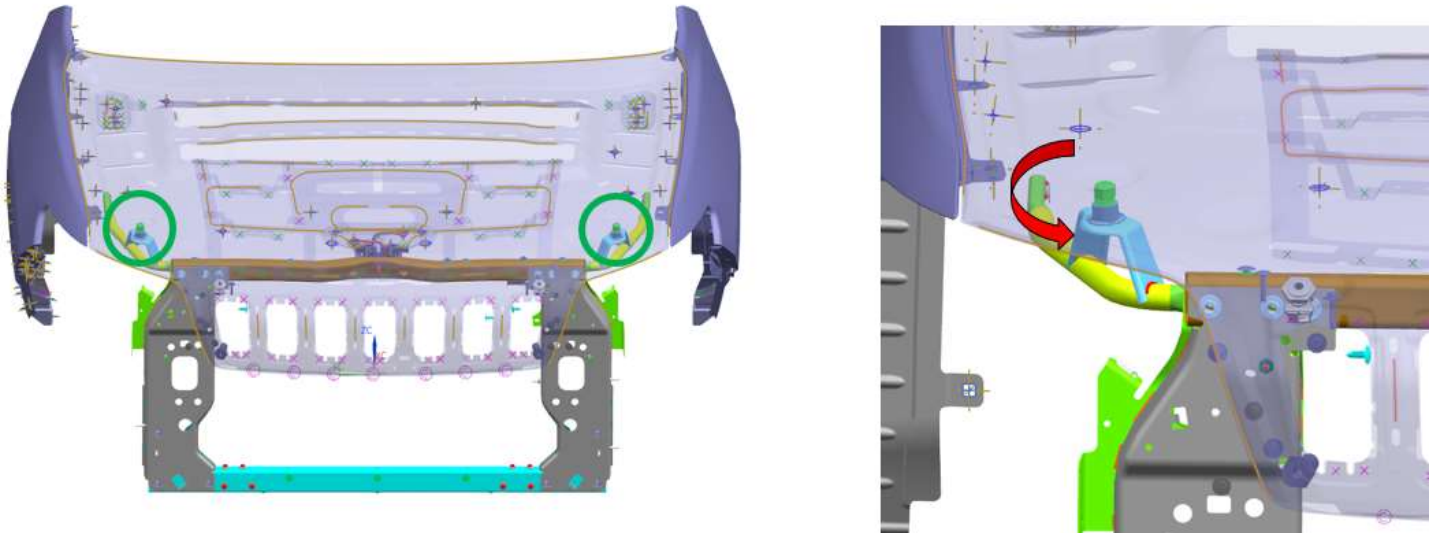

**Fig 4**

4. If the front of the hood is no longer shaking while driving, but the hood sheet metal is moving examine the hood's anti flutter foam for separation. The green dashed lines show the anti-flutter foam in Fig 5.

This document does not authorize warranty repairs. This communication documents a record of past experiences. STAR Online does not provide any conclusions about what is wrong with the vehicle. Rather, it captures all previous cases known that appear to be similar or related to the vehicle symptom / condition. You are the expert, and you are responsible for deciding on the appropriate course of action.

**Contact STAR Center, or your Technical Assistance Center Via TechCONNECT or eCONTACT ticket if no solution is found**

## STAR ONLINE PUBLICATION

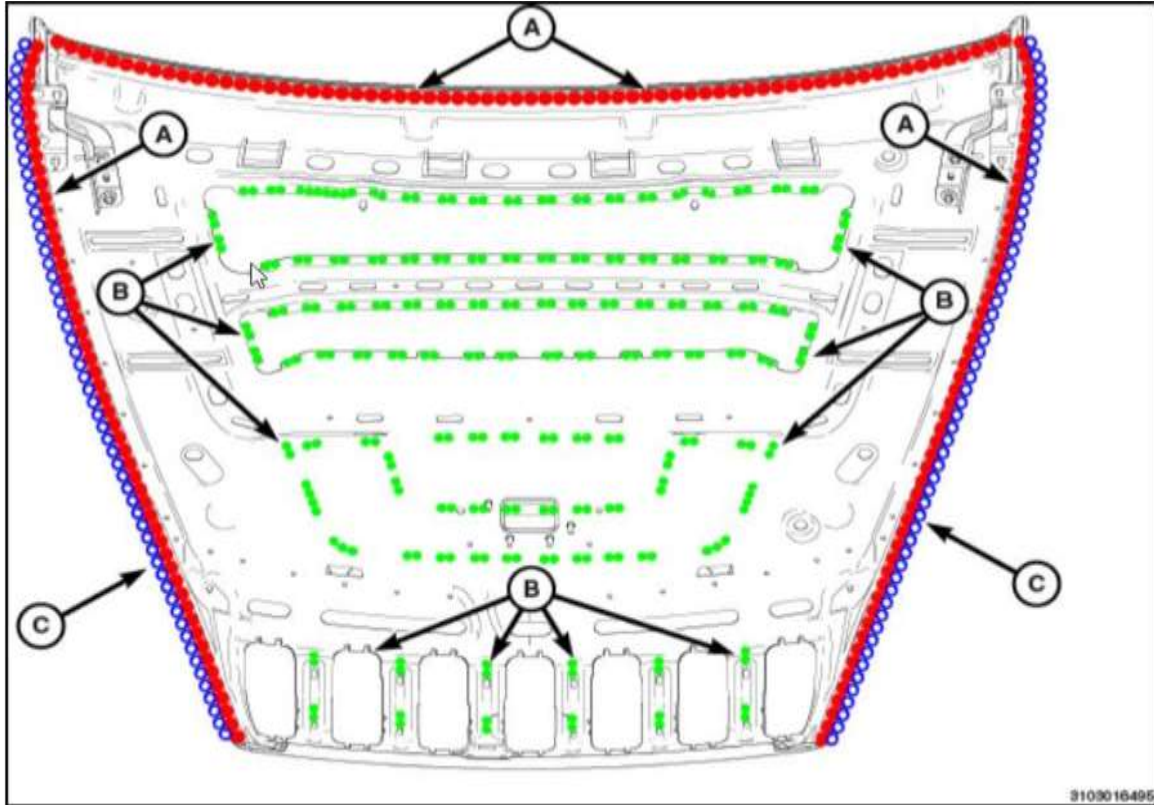

Fig 5 Anti-Flutter Foam shown in green (B)

**Anti-Flutter Adhesive (flexible)** : Fusor 121 (flexible foam), 3M 04724 (NVH dampening material) and Crest (CFF Flexi-Foam). Refer to group 31- Collision Information. Follow product application and curing instructions.

This document does not authorize warranty repairs. This communication documents a record of past experiences. STAR Online does not provide any conclusions about what is wrong with the vehicle. Rather, it captures all previous cases known that appear to be similar or related to the vehicle symptom / condition. You are the expert, and you are responsible for deciding on the appropriate course of action.

**Contact STAR Center, or your Technical Assistance Center Via TechCONNECT or eCONTACT ticket if no solution is found**